

HP 8746B

TLC/000420

OPERATING AND SERVICE MANUAL

S-PARAMETER TEST SET

.5-12.4 GHz
8746B

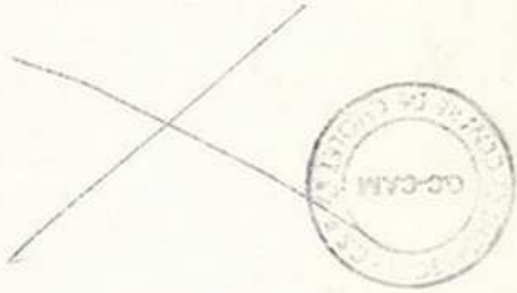

HEWLETT  PACKARD

HP 8746B

HP 8746b 0.5-12.4 GHz S-parameter test-set

Table of Contents

Model 8746B

TABLE OF CONTENTS

Section	Page	Section	Page
I GENERAL INFORMATION	1-1	4-8. Source Match	4-5
1-1. Introduction	1-1	4-9. Return Match	4-5
1-3. Instruments Covered by Manual	1-1		
1-7. Operating Information Supplement	1-1		
1-9. Table of Specifications	1-1	V ADJUSTMENTS	5-1
1-11. Supplementary Operating Characteristics	1-1	5-1. Introduction	5-1
1-13. Recommended Test Equipment	1-1	5-3. Equipment Required	5-1
1-15. Description	1-1	5-5. Electrical Adjustments	5-1
1-17. Options	1-1	5-7. Mechanical Adjustments	5-1
1-19. Option 001	1-2		
1-21. Option 002	1-2		
1-23. Accessories Supplied	1-2	VI REPLACEABLE PARTS	6-1
1-25. Equipment Required but Not Supplied	1-2	6-1. Introduction	6-1
1-27. Equipment Available	1-2	6-6. Ordering Information	6-1
1-28. Model 11608A Transistor Fixture	1-2		
1-30. Other Reference Line Coaxial Cables	1-2		
1-32. Model 11605A Flexible Arm	1-3		
		VII MANUAL CHANGES	7-1
II INSTALLATION	2-1	7-1. Introduction	7-1
2-1. Initial Inspection	2-1		
2-2. Mechanical Check	2-1		
2-4. Electrical Checks	2-1	VIII SERVICE	8-1
2-6. Claims for Damage	2-1	8-1. Introduction	8-1
2-9. Preparation for Use	2-1	8-2. Principles of Operation	8-1
2-10. Power Requirements	2-1	8-6. Recommended Test Equipment	8-1
2-12. 115/230 Volt Operation	2-1	8-12. Component Trouble Isolation	8-1
2-14. Three-Conductor Power Cable	2-1	8-17. Assembly Replacement	8-2
2-17. Operating Environment	2-1	8-18. Pushbutton Circuit Boards	8-2
2-20. Storage and Shipment	2-1	8-20. Switch Tree A	8-2
2-21. Packaging	2-1	8-22. Switch Tree B	8-4
		8-25. Step Attenuator (A6) Assembly	8-5
III OPERATION	3-1	8-27. Line Stretcher (A5) Assembly	8-6
3-1. Introduction	3-1	8-28. Directional Coupler DC1 (Port 1 Coupler)	8-7
3-3. Panel Features	3-2	8-30. Directional Coupler DC2 (Port 2 Coupler)	8-8
3-5. Operating Precautions	3-2	8-32. Directional Coupler DC3	8-9
3-6. Maximum RF Power	3-2	8-34. Port Coupler 10 dB Attenuator	8-9
3-8. RF Power to Test Device	3-2	8-36. Port 1 and Port 2 Connector Coupling Assemblies	8-10
3-10. Maximum DC on RF Lines	3-2	8-38. Repair	8-10
3-12. Operator's Check	3-2	8-39. Replaceable Parts	8-10
3-14. Operating Instructions	3-2	8-41. Location Diagrams	8-10
3-15. General Measurement Description	3-2	8-43. Troubleshooting	8-11
3-18. Transistor Bias Supply Connection and Adjustments	3-3	8-44. Introduction	8-11
3-21. Bias Using a Dual DC Power Supply	3-9	8-48. Troubleshooting Procedure	8-11
3-24. Remote Operation	3-10	8-50. Troubleshooting from Front-Panel Indications	8-11
3-28. Remote Operation Requirements	3-10	8-52. Troubleshooting from the Display Indicator	8-11
3-30. Operator's Maintenance	3-11	8-64. Schematic Diagram Notes	8-12
3-31. Care of APC-7 Connectors	3-11	8-65. Schematic Symbols	8-12
3-39. Fuses	3-11	8-67. Selected/Non-Selected Terminology	8-12
3-42. Line Switch Bulb Replacement	3-12		
3-44. Pushbutton Switch Bulb Replacement	3-12		
IV PERFORMANCE TESTS	4-1		
4-1. Introduction	4-1		
4-3. Equipment Required	4-1		
4-5. Test Record	4-1		
4-7. Directivity	4-1		

LIST OF ILLUSTRATIONS

Figure	Page	Figure	Page
1-1. Model 8746B and Accessories	1-0	8-3. Reference Channel Troubleshooting	8-15
1-2. Model 11608A Transistor Fixture Mounted on a Model 8746B	1-2	8-4. Test Channel Troubleshooting	8-16
3-1. Block Diagram of Equipment Setup for S-Parameter Measurement	3-1	8-5. Assembly, Top View	8-17
3-2. Front Panel Features	3-4	8-6. Assembly, Bottom View	8-17
3-3. Rear Panel Features	3-5	8-7. Index Block Diagram & Interconnection Diagram	8-17
3-4. Standard Model RF Circuits	3-6	8-8. RF Troubleshooting	8-18
3-5. Option 001 and 002 RF Circuits	3-7	8-9. RF Circuitry, Top View	8-18
3-6. Reference Line Coaxial Patch Cables	3-8	8-10. RF Circuitry, Bottom View	8-19
3-7. Line Switch Bulb Replacement	3-12	8-11. Port 1 to Port 2 Coupler Schematic	8-19
3-8. Bias Voltage Input Connections	3-13	8-12. RF Circuit, Schematic	8-19
3-9. Transistor Measurement	3-14	8-13. S-Parameter Troubleshooting	8-20
3-10. Microwave Hardware Measurement	3-16	8-14. A4 Switch Panel Assembly, Parts Location	8-20
3-11. APC-7 Connectors	3-18	8-15. A3 Driver Assembly, Parts Location	8-21
3-12. Pushbutton Selector Bulb Replacement	3-19	8-16. S-Parameter Latch and Driver Circuits, Schematic	8-21
4-1. Directivity Test Setup	4-2	8-17. Attenuation Select Troubleshooting	8-22
4-2. Source Match Test Setup	4-4	8-18. A4 Switch Panel Assembly Parts Location	8-22
4-3. Return Match Test Setup	4-6	8-19. A2 Buffer Assembly Parts Location	8-23
5-1. Digital Counter Friction Clutch Adjustment	5-2	8-20. Attenuation Latch Circuits	8-23
6-1. Cabinet Parts	6-13	8-21. Attenuation Select Troubleshooting	8-24
6-2. Front Panel Assembly	6-14	8-22. A6 Attenuator Assembly Troubleshooting	8-24
6-3. REFERENCE & TEST Channel Output and Inboard (W3J1) REFERENCE LINE Connectors	6-15	8-23. A3 Driver Assembly, Parts Location	8-25
6-4. Outboard (W1J1) REFERENCE LINE Connector	6-16	8-24. Attenuator Driver Circuits	8-25
6-5. REFERENCE LINE Coaxial Cable Connectors (2)	6-17	8-25. Remote Control Troubleshooting	8-26
8-1. Troubleshooting Test Setup	8-13	8-26. Remote S-Parameter, Block Diagram	8-26
8-2. Preliminary Troubleshooting	8-14	8-27. Remote Attenuator, Block Diagram	8-26
		8-28. A2 Buffer Assembly, Parts Location	8-27
		8-29. Remote Control Circuits	8-27
		8-30. Power Supply Troubleshooting	8-28
		8-31. Power Supply Adjustments	8-28
		8-32. A1A1 Power Supply Assembly, Parts Location	8-28
		8-33. A2 Buffer Assembly, Parts Location	8-29
		8-34. Power Supply, Schematic	8-29

LIST OF TABLES

Table	Page	Table	Page
1-1. Model 8746B Specifications	1-3	8-1. Servicing Aids	8-1
1-2. Supplementary Operating Characteristics	1-3	8-2. Schematic Diagram Notes	8-3
1-3. Recommended Test Equipment	1-4	8-3. Paths Common to Various S-Parameter Paths	8-18
3-1. Calibrator Display Indications	3-3	8-4. S-Parameter Truth Table	8-20
3-2. Remote Input Connector Pin Functions	3-9	8-5. S-Parameter Voltage Table	8-20
3-3. Remote S-Parameter Selection Truth Table	3-10	8-6. Attenuator Truth Table	8-22
3-4. Remote Attenuation Selection Truth Table	3-11	8-7. Attenuation Latch Voltage Table	8-22
4-1. Performance Test Record	4-8	8-8. Attenuator Driver Truth Table	8-24
6-1. Reference Designators and Abbreviations Used in Parts List	6-1	8-9. Attenuator Driver Voltage Table	8-24
6-2. Replaceable Parts	6-3	8-10. Remote Control Parameter and Attenuation Select Truth Table	8-26
		8-11. Remote Control Voltage Table	8-26

HP 8746b 0.5-12.4 GHz S-parameter test-set

General Information

Model 8746B



Figure 1-1. Model 8746B and Accessories

1-0

SECTION I GENERAL INFORMATION

1-1. INTRODUCTION

1-2. This manual contains all information required to install, operate, test, adjust and service the Hewlett-Packard Model 8746B S-Parameter Test Set. This section covers instrument identification, description, options, accessories, specifications and other basic information. Included with this manual is the Operating Information Supplement which is a reprint of the first three sections of this manual. Figure 1-1 shows all of the equipment normally supplied with the instrument for the standard Model or Option 001 or 002. Table 1-1 in the manual is the Table of Specifications.

1-3. INSTRUMENTS COVERED BY MANUAL

1-4. The Model 8746B S-Parameter Test Set carries a nine-digit and one-letter serial number. The first four digits form the serial prefix number. The last five digits of the serial number form the sequential suffix, unique to each individual instrument.

1-5. This manual is directly applicable to instruments with Serial Prefix numbers the same as those listed on the title page. For instruments with Serial Prefix numbers lower than those listed on the title page, refer to Section VII. Important information for correcting errors, and for adapting the contents of this manual to cover instruments manufactured after the printing of the manual, is provided in a yellow Manual Changes supplement inserted under the front cover of the manual. These supplements are keyed to the manual's print date and part number, both of which appear on the title page, and they are revised as often as necessary to keep the manual current and accurate. To maintain the manual as current and accurate as possible, Hewlett-Packard recommends that you periodically request the latest Manual Changes supplement. Complimentary copies of these supplements are available from all Hewlett-Packard offices.

1-6. For information concerning serial number prefixes not listed on the title page or in a Manual Changes supplement, contact the nearest Hewlett-Packard office.

1-7. OPERATING INFORMATION SUPPLEMENT

1-8. Packaged with this basic manual is an Operating Information Supplement which is a reprint of the first three sections of this manual. This supple-

ment should stay with the instrument for use by the instrument operator. Additional copies may be ordered through your local Hewlett-Packard office.

1-9. TABLE OF SPECIFICATIONS

1-10. Complete specifications are listed in Table 1-1. These specifications are the performance standards or limits against which the instrument may be tested. Use these limits when testing for incoming inspection or at any time the performance of the instrument is in question.

1-11. SUPPLEMENTARY OPERATING CHARACTERISTICS

1-12. Table 1-2 lists supplementary operating characteristics. These values are not specifications, but are included for the information of the user.

1-13. RECOMMENDED TEST EQUIPMENT

1-14. Table 1-3 lists recommended test equipment for performance testing, troubleshooting, and maintenance.

1-15. DESCRIPTION

1-16. The HP Model 8746B S-Parameter Test Set contains the necessary microwave circuits for measuring all four s-parameters of an active or passive two-port device from 0.5 to 12.4 GHz. The Model 8746B is designed primarily to be used with the Hewlett-Packard Model 11608A Transistor Fixture. However, measurements on other microwave devices may also be made by inserting the necessary coaxial line-lengths in the rear panel reference line. The Model 8746B is used with a compatible phase-amplitude ratio indicator, such as the HP Model 8410A Network Analyzer or Model 8405A Vector Voltmeter. Measuring circuits for each s-parameter are automatically set with front-panel pushbuttons or with remote-contact closures. Attenuation of the incident RF signals can also be set with front-panel pushbuttons or remote contact-closures. Figure 3-4 is a diagram of the RF circuits for the standard 8746B.

1-17. OPTIONS

1-18. Figure 3-5 is a diagram of the RF circuits for Option 001 and Option 002. The main difference in the instruments containing an option is that the input and output cables going to the switch trees

have been interchanged. Option 002 also removes the 10-dB attenuators in the port couplers to increase the signal level at the test port.

1-19. Option 001

1-20. The HP Model 8746B, Option 001, has a signal level at the test port that is 10 dB higher than the standard instrument for the same level of RF power into the test set. This allows making large-signal measurements on power transistors and mixers.

1-21. Option 002

1-22. The HP Model 8746B, Option 002, has a signal level at the test port that is 20 dB higher than the standard instrument for the same level of RF power into the test set. This option is usually used for automatic measurement of large-signal parameters or large dynamic-range measurement. This option is normally limited to use in automatic measurement systems since source-match and return-match specifications are degraded in this configuration.

1-23. ACCESSORIES SUPPLIED

1-24. A rack-mounting kit, a power cable (HP Part No. 8120-1348), a reference line coaxial cable (HP Part No. 11604-20021), and a 36-pin connector are furnished with the 8746B. (See Figure 1-1.) The rack-mounting kit contains all the hardware needed to adapt the Model 8746B cabinet for installation in equipment racks with standard 19-inch spacing. Instructions for conversion to rack mounting are included with the kit. The reference line coaxial

cable furnished will enable you to make transistor measurements with the 8746B using the 11608A Transistor Fixture. When making microwave hardware measurements other reference-line coaxial cables may need to be substituted. Refer to the paragraph entitled "Equipment Available" for further information.

1-25. EQUIPMENT REQUIRED BUT NOT SUPPLIED

1-26. The Model 8746B must be used with a phase-amplitude ratio indicator, such as the HP Model 8410A Network Analyzer System or the Model 8405A Vector Voltmeter.

1-27. EQUIPMENT AVAILABLE

1-28. Model 11608A Transistor Fixture

1-29. Transistors are tested with the Model 8746B by using an additional fixture, the Hewlett-Packard Model 11608A Transistor Fixture (Figure 1-2). Refer to the Model 11608A Operating Note for operating instructions on this transistor fixture.

1-30. Other Reference Line Coaxial Cables

1-31. The reference line coaxial cable furnished with the 8746B allows transmission and reflection tests to be made on transistors using the 11608A. To make reflection measurements on microwave hardware, the use of a shorter reference line (HP Part No. 08745-20064) is recommended. Microwave transmission measurements require the use of a longer reference line (HP Part No. 08746-20031). Unless the port spacing on the device under test is



Figure 1-2. Model 11608A Transistor Fixture Mounted on a Model 8746B

HP 8746b 0.5-12.4 GHz S-parameter test-set

Model 8746B

General Information

the same as on the 8746, an additional component, a Flexible Arm HP Model 11605A, will be necessary.

1-32. Model 11605A Flexible Arm

1-33. If the port spacing of the device under test is not the same as that of the Model 8746B, a Flexi-

ble Arm, Hewlett-Packard Model 11605A, should be used on one port of the device under test with the other port connected to the 8746B. The Model 11605A consists of three rotary-arms connected by three swivel-adapters. This configuration allows almost any coaxial two-port device to be connected to the 8746B.

Table 1-1. Model 8746B Specifications

<p>Frequency Range: 0.5 to 12.4 GHz.</p> <p>Directivity: ≥ 30 dB, 0.5 to 4.0 GHz ≥ 26 dB, 4.0 to 12.4 GHz.</p> <p>Source Match:¹ $\rho \leq 0.13$ (≤ 1.3 SWR), standard model only.</p> <p>Return Match:² $\rho \leq 0.13$ (≤ 1.3 SWR), standard model only.</p> <p>Reference Plane Extension: Adds 0 to 15 cm (30 cm in transmission path) to reference line; calibrated by digital dial indicator. Indicator is adjustable for initial calibration.</p> <p>Connectors: RF Input: Type N female, stainless steel Test Ports: APC-7 type Reference and Test Channel Outputs: mates with APC-7 precision connectors.</p> <p>Maximum Power to RF Input: 2 watts.</p> <p>Insertion Loss: RF Input to Test Port, Standard Configuration — Nominal 21 dB, Option 001 — Nominal 11 dB, Option 002 — Nominal 1 dB. RF Input to Reference Channel Output — Nominal 30 dB.</p> <p>Remote Programming: Selected by closing contact of 36-pin rear panel connector to common.</p> <p>S-Parameter Selection: By closing 2 contacts of 36-pin rear panel connector to common.</p> <p>Incident Attenuation: By closing 3 contacts of 36-pin rear panel connector to common.</p> <p>Rear-panel switch allows manual attenuator operation when s-parameters are remotely controlled.</p>	<p>Remote Requirements: Switch closure to common, or use a transistor switch. Contact is at 12 volts and short to common will draw 12 mA. Noise immunity > 2 V peak.</p> <p>Transistor Biasing: Bias and bias sensing connections are made to the biasing networks built into the 8746B via the 36-pin rear-panel connector.</p> <p>Maximum Bias: ± 100 Vdc, 500 mA. Maximum current of 1 amp when bias and bias sense circuits are operated in parallel.</p> <p>Configuration: Standard: Recommended for small-signal measurements; has the optimum signal-to-noise ratio.</p> <p>Option 001: Provides 10 dB higher power level at test port. Enables large-signal parameter measurements.</p> <p>Option 002: Provides 30 dB higher power at the test port and 10 dB greater dynamic range. Source and Return Match specifications are degraded. Recommended for Automatic Network Analyzer Systems only.</p> <p>Power Requirements: 115V/230V $\pm 10\%$, 48 to 440 Hz, 110VA max.</p> <p>Weight: Net 35 lbs (16,1 kg).</p> <p>Dimensions: 5½ inches high, 16¾ inches wide, 18¾ deep (140 x 426 x 467 mm).</p> <p>¹Equivalent source reflection coefficient. ²Reflection coefficient of port used to terminate device under test.</p>
---	--

Table 1-2. Supplementary Operating Characteristics

<p>These values are not specifications but are typical performance characteristics included for information of the user.</p> <p>Frequency Response (Amplitude and Phase Tracking): 1.5 dB, ± 7 degrees, 0.5 to 2.0 GHz 1.5 dB, ± 7 degrees, 2.0 to 8.0 GHz 2.5 dB, ± 7 degrees, 8.0 to 12.4 GHz.</p>	<p>Incident Attenuation: 0–70 dB in 10 dB steps. Attenuation is within $\pm 5\%$ of indicated value.</p> <p>Test Port Spacing: 4.810 inches.</p>
---	---

HP 8746b 0.5-12.4 GHz S-parameter test-set

General Information

Model 8746B

Table 1-3. Recommended Test Equipment

Instrument Type	Critical Specifications	Recommended Model	Use ¹
Sweep Oscillator	Frequency: 0.5 to 12.4 GHz	HP 8690A/B mainframe with HP 8699B (0.11 to 4 GHz) HP 8691A/B (1 to 2 GHz) HP 8692A/B (2 to 4 GHz) HP 8693A/B (4 to 8 GHz) HP 8694A/B (8 to 12.4 GHz)	P,T P P P P P
Network Analyzer	No substitute may be used	HP 8410A/8411A with HP 8412/3/4A	P,T
Flexible Arm	Frequency: 0.5 to 12.4 GHz Impedance: 50 ohm coaxial SWR of ports: ≤ 1.25 Insertion Loss: ≤ 2.5 dB	HP 11605A	P
Sliding Load	Frequency: 1.8 to 12.4 GHz Load SWR: ≤ 1.05	HP 905A	P
Coaxial Termination	Frequency: 0.5 to 2.0 GHz Load SWR: ≤ 1.01	HP 909A, Option H01	P
Coaxial Short	Frequency: 0.5 to 12.4 GHz Connector: APC-7	HP 11565A	P,T
Oscilloscope	Vertical Sensitivity: 25 mV/cm Vertical Bandwidth: 500 kHz Horizontal Sensitivity: 1V/cm	HP 180A w/1801A & 1821A	P,T
Voltohmmeter	Voltage Range: 300 volts Accuracy: $\pm 5\%$ Ohmmeter: One range not over 1.5V open circuit; nor over 1 mA closed circuit for testing transistors.	HP 412A	T,A
Power Meter	Range: -20 dBm to +10 dBm Compatible with Thermistor Mount	HP 432A	T
Thermistor Mount	Range: -20 dBm to +10 dBm Compatible with Power Meter	HP 478A	T
X-Y Recorder	Input Ranges: 0.1, 1, and 10V/in., continuous vernier between ranges. Zero Set: zero may be set up to one full-scale indication in any direction from zero index.	HP 7035B	T
Remote Operation Tester	Amphenol 36-pin connector with pin connections accessible	HP Part No. 08620-60037	T
DC Ammeter	Range: up to 1 ampere Accuracy: $\pm 3\%$	HP 428A	T
Variable Voltage Transformer	Range: 102 to 127 Vac	General Radio W5MT3A or Superior Electric UC1M	T,A
¹ NOTE P = Performance Test; A = Adjustments; T = Troubleshooting			

SECTION II INSTALLATION

2-1. INITIAL INSPECTION

2-2. Mechanical Check

2-3. If damage to the shipping carton is evident, ask that the carrier's agent be present when the instrument is unpacked. Inspect the instrument for mechanical damage. Also, check the cushioning material for signs of severe stress.

2-4. Electrical Checks

2-5. The electrical performance of Model 8746B should be verified on receipt. A performance test suitable for incoming inspection is given in Section IV, Performance Test. Equipment required for the performance test is listed in Table 1-3.

2-6. Claims for Damage

2-7. If the Model 8746B is mechanically damaged in transit, notify the carrier and the nearest Hewlett-Packard office immediately. Retain the shipping carton and packing material for the carrier's inspection. The HP office will arrange for replacement or repair of your instrument without waiting for claims settlement against the carrier.

2-8. Before shipment, this instrument was inspected and found free of electrical and mechanical defects. If there is any deficiency, or if the electrical performance is not within specification, notify your Hewlett-Packard office.

2-9. PREPARATION FOR USE

2-10. Power Requirements

2-11. The Model 8746B requires a power source of 115 or 230 Vac $\pm 10\%$, 48 to 400 Hz, single-phase power. Power consumption is less than 110 VA.

2-12. 115/230 Volt Operation

2-13. This instrument has a power module that is a combination of power-cable receptacle, fuse holder, and input-voltage switch. To change the input voltage circuit proceed as follows:

- a. Remove power cable.
- b. Slide clear plastic cover of module to left.
- c. Pull out on handle marked "FUSE PULL".

- d. Remove fuse.

e. With a screwdriver or pointed tool, move the switch arm with the arrow to 115 or 230 position. The right-hand position is for 115 volt input and the left-hand position is for 230 volt input.

- f. Replace fuse with a fuse of correct value.
- g. Slide clear plastic cover to right.
- h. Replace power cable.

2-14. THREE-CONDUCTOR POWER CABLE

2-15. To protect operating personnel, the National Electrical Manufacturers Association (NEMA) recommends that the instrument panel and cabinet be grounded. All Hewlett-Packard instruments are equipped with a 3-conductor power cable which, when plugged into an appropriate receptacle, grounds the instrument. The *offset pin* on the 3-prong connector of the power cable is the ground wire.

2-16. To preserve the protection feature when operating the instrument from a 2-conductor output, use a 3-prong to 2-prong adapter and connect the pigtail on the adapter to ground.

2-17. OPERATING ENVIRONMENT

2-18. The normal operating environment for the Model 8746B is room temperature (25 degrees C), but it will operate to its specified performance from 0 to +55 degrees C. It will operate in any humidity up to 95%.

2-19. The instrument cabinet has plastic feet for bench operation. The plastic feet are shaped to make full-width modular instruments self-aligned when stacked.

2-20. STORAGE AND SHIPMENT

2-21. Packaging

2-22. **Original-Type Packaging.** Containers and packing materials identical to those used by the factory are available through your nearest Hewlett-Packard office. Remove the rear-panel reference line, wrap it separately, and include it in the shipping container. If the 8746B is being returned for servicing and repair, attach a tag indicating type of

service required, full return address, and full instrument serial number. Also mark the box "FRAGILE" to assure careful handling. In any correspondence regarding your instrument, refer to the instrument by its full HP model number and serial number.

2-23. Other Packing Materials. The following general instructions should be used for repackaging with commercially available materials:

a. Remove the rear-panel reference line, wrap it separately, and include it in the shipping container. Wrap the instrument in heavy paper or plastic. (If shipping to a Hewlett-Packard service office or center, attach a tag indicating the type of service required, return address, model number, and full serial number.)

b. Use a strong shipping container. A double-wall carton made of 350 lb. test material is adequate.

c. Use enough shock-absorbing material (3 to 4 inch layer) around all sides of the instrument to provide firm cushion and prevent movement inside the container. Protect the control panel with cardboard.

d. Seal the shipping container securely.

e. Mark the shipping container "FRAGILE" to assure careful handling.

SECTION III OPERATION

3-1. INTRODUCTION

3-2. The combination of the Model 8746B S-Parameter Test Set with its accessory fixtures and adapters, a signal source, and a compatible phase-amplitude ratio indicator, such as the HP Model 8410A Network Analyzer or Model 8405A Vector Voltmeter (see Figure 3-1) make up a system for measuring s-parameters of almost any transistor or device. These measurements can be performed at single frequencies or at swept frequencies, from 0.5 to 12.4 GHz. When used with the HP Model 8405A Vector Voltmeter, measurements are limited to single frequencies of 1 GHz or less. The Model 8746B can be used at frequencies below 500 MHz; however, coupling attenuation of

the internal directional couplers increases by about 6 dB/octave and source and return match are degraded below about 150 MHz. For 8746B Options 001 & 002, the RF signal at the TEST port increases 6 dB/octave below 500 MHz when the signal level at the reference channel is kept constant. Consequently, when making measurements below 500 MHz the input level should be monitored closely. Make sure power limits are not exceeded when increasing power to get a reading on the display indicator. For Option 002, place a 3-dB pad at the RF INPUT connector for a better impedance match at low frequencies when measuring active devices. This pad will reduce the possibility of low frequency oscillation with active devices under test.

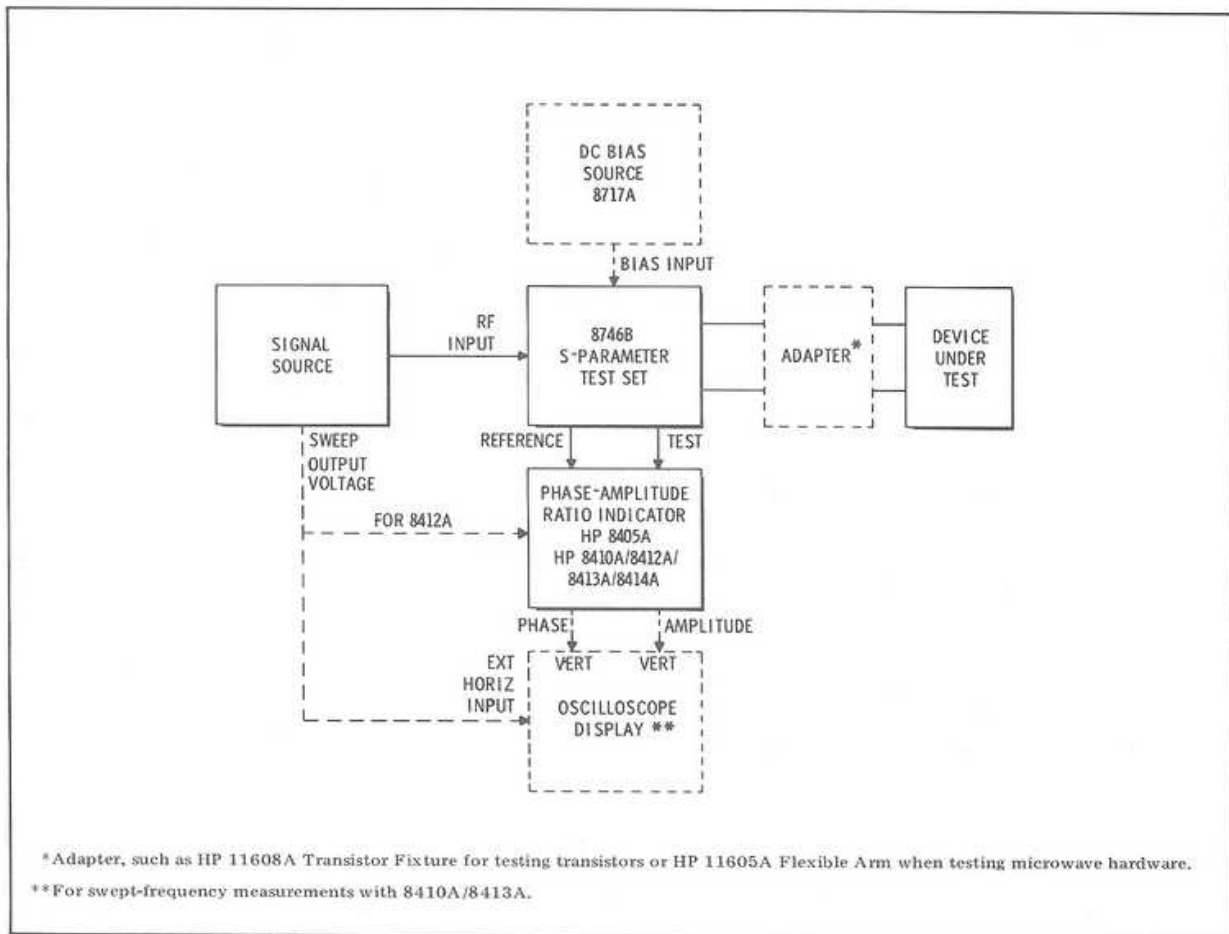

Figure 3-1. Block Diagram of Equipment Setup for S-Parameter Measurement

3-3. PANEL FEATURES

3-4. Front and rear panel controls, connectors, and indicators are described in Figures 3-2 and 3-3. In these figures the numbers on the illustration are keyed to the description numbers.

3-5. OPERATING PRECAUTIONS

3-6. Maximum RF Power

3-7. Power in excess of 2 watts, either into the RF INPUT jack or returned from an active device under test into PORT 1 or PORT 2 may damage the instrument. Also, do not exceed the input power limit of the associated network analyzer.

3-8. RF Power to Test Device

CAUTION

Do NOT use excessive RF input power to the device under test. Too much RF may cause the transistor to oscillate. If the collector current varies with RF input power, investigate the possibility of oscillation.

3-9. On all models of the 8746B, power to the device under test may be decreased using the internal step-attenuator without reducing reference channel output. When the standard 8746B internal step-attenuator is set to zero, power to the device under test is approximately 21 dB below RF input level and power at the reference channel is approximately 31 dB down. For Option 001, when the attenuator is set to zero, power to the device under test is approximately 11 dB below the RF input level. For Option 002, when the attenuator is set to zero, power to the device under test is at the same level as the RF input. For both Options 001 and 002, with the power at the reference port held constant, power to the device under test increases at approximately 6 dB/octave below 500 MHz. RF circuits for the standard model 8746B in all s-parameter configurations are shown in Figure 3-4. The same circuits for Options 001 and 002 are shown in Figure 3-5.

3-10. Maximum DC on RF Lines

3-11. DC voltages on the inner conductor of the transmission lines in the Model 8746B must not exceed ± 100 volts as the insulation of the internal capacitors may break down. Do not draw more than 0.5 amp on either Bias or Bias Sense leads.

3-12. OPERATOR'S CHECK

3-13. To check the 8746B operation, set up to calibrate the system for a measurement. Observe the calibration trace. The 8746B is operating

3-2

properly if the amplitude variations in the calibration trace are less than 2.5 dB¹ and the 8746B pushbuttons function normally. If the 8746B will not calibrate properly, refer to Section VIII, Service.

3-14. OPERATING INSTRUCTIONS

3-15. General Measurement Description

3-16. The Model 8746B S-Parameter Test Set may be used to make measurements with several combinations of complementary equipment. A simplified block diagram of a test setup is shown in Figure 3-1. The display indicator is a phase-magnitude ratio indicator, such as the HP 8405A or the HP 8410A/8411A with 8412A, 8413A with an external oscilloscope, or 8414A plug-in. Instructions for using the 8410A system are given in Figures 3-9 and 3-10. These instructions can be modified for use with the 8405A by referring to the Operating and Service Manual for the 8405A and adapting the instructions for single-frequency operation at lower frequencies. Transistors are tested by connecting the HP Model 11608A Transistor Fixture to the 8746B and inserting the transistor under test in the 11608A. Other components also may be tested in the 11608A, providing the physical limits of the 11608A are not exceeded. Consult the nearest Hewlett-Packard office. Microwave hardware may be connected to the S-Parameter Test Set by accessories, such as the Model 11605A Flexible Arm.

3-17. The following general outline explains the steps necessary when making measurements with any combination of equipment. These instructions are the same for both the standard and Option 001 and 002 models of the 8746B.

- a. If swept-frequency phase measurements are to be made, the reference and test channel line-lengths must be equal. The length of the reference channel is adjusted by varying the REFERENCE PLANE EXTENSION and the length of the REFERENCE LINE coaxial patch cable on the rear panel. The REFERENCE LINE can be removed and other length reference lines (see Figure 3-6) can be installed to approximately equalize the test and reference channel line lengths. To best utilize the REFERENCE PLANE EXTENSION range, install one of the following REFERENCE LINE coaxial patch cables:

TRANSISTOR FIXTURE (11608A): Use HP Part No. 11604-20021 included with 8746B.

¹Notches of 1 dB at approximately 700 MHz are normal. They are caused by resonances of RF chokes in the bias input leads.

MICROWAVE HARDWARE:

Reflection: Use HP Part No. 08745-20064.

Transmission with Device Under Test Terminated in an HP 11605A: Use HP Part No. 08746-20031.

Note

When using the 11605A the accuracy of the measurement may be degraded due to mismatch. Use a 10 dB isolating attenuator (see Figure 3-10) to reduce mismatch.

CALIBRATION

b. Calibrate the system for s-parameter measurement by terminating the 11608A with a short or through-line calibrator. When measuring microwave hardware, calibrate the 8746B with a coaxial short connected to the test port for reflection measurements or a through-line calibrator consisting of a 11605A connected between the test ports for transmission measurements.

1. Balance the electrical length of the reference and test channels by adjusting the REFERENCE PLANE EXTENSION to obtain the least phase change with frequency indication on the display indicator.¹
2. Adjust the controls on the display indicator for a display indication corresponding to the calibrator being used as shown in Table 3-1.

Table 3-1. Calibrator Display Indications

S-Parameter	Calibrator	Magnitude	Phase
S_{11}, S_{22}	Short	1.0	180°
S_{21}, S_{12}	Thru-Line	1.0	0°

MEASUREMENT

c. Remove calibrator and connect the device under test. If a transistor is to be tested, it must be biased properly. Refer to paragraph 3-18 for transistor-biasing instructions.

d. Measure the parameter of the device under test. Additional accuracy may be obtained by compensating for the directivity error as described in Application Note 117-1, "Microwave

¹Refer to HP Application Note 117-2 "Stripline Component Measurements with the Model 8410A Network Analyzer", obtainable free from any Hewlett-Packard office, for operating instructions concerning other instruments in the measurement system.

Network Analyzer Applications." This note gives general Network Analyzer techniques while Application Note 117-2, mentioned earlier, gives specific 8746B applications.

Detailed procedures for both calibration and measurement with either transistors or microwave hardware are shown in Figures 3-9 and 3-10.

3-18. Transistor Bias Supply Connection and Adjustments

3-19. A transistor under test may be biased by either a HP Model 8717A Transistor Bias Supply or by a dual dc-power supply. Instructions for connecting and adjusting these power supplies are given in the following paragraphs. An 8746B simplified internal-bias circuit is shown in Figure 3-8. Before connecting any bias the following steps should be performed:

- a. Determine maximum allowable voltages and currents for both the input and output circuits of the transistor under test.
- b. Draw simplified circuit of transistor in test fixture. Label input circuit "port 1 circuit" and output circuit "port 2 circuit". The common point between the two circuits is chassis ground.
- c. Determine the polarities of the input and output circuit (bias) voltages.
- d. If a Model 8717A is used for bias, refer to the following paragraph. If a dual dc-power supply is used for bias, refer to paragraph 3-21.

CAUTION

AVOID BIAS SUPPLY SWITCHING TRANSIENTS DURING TESTING! Turn down bias-supply voltages or currents before switching bias-supply meter functions. Also, turn down the input circuit control and then bring it up to operating conditions rather than merely switching the bias supply output off and on. If supplies are merely switched on, switching transients may damage sensitive transistors. If the power supplies are programmed, include a zero-voltage or zero-current program step between each voltage or current setting.

3-20. Bias Using the HP Model 8717A. On the HP Model 8717A, bias and bias-sensing connections are selected by means of 8717A front-panel switches. A cable, furnished with the 8717A, connects the 8717A to the 8736B rear-panel REMOTE INPUT connector. If no cable is available the necessary connections are given in

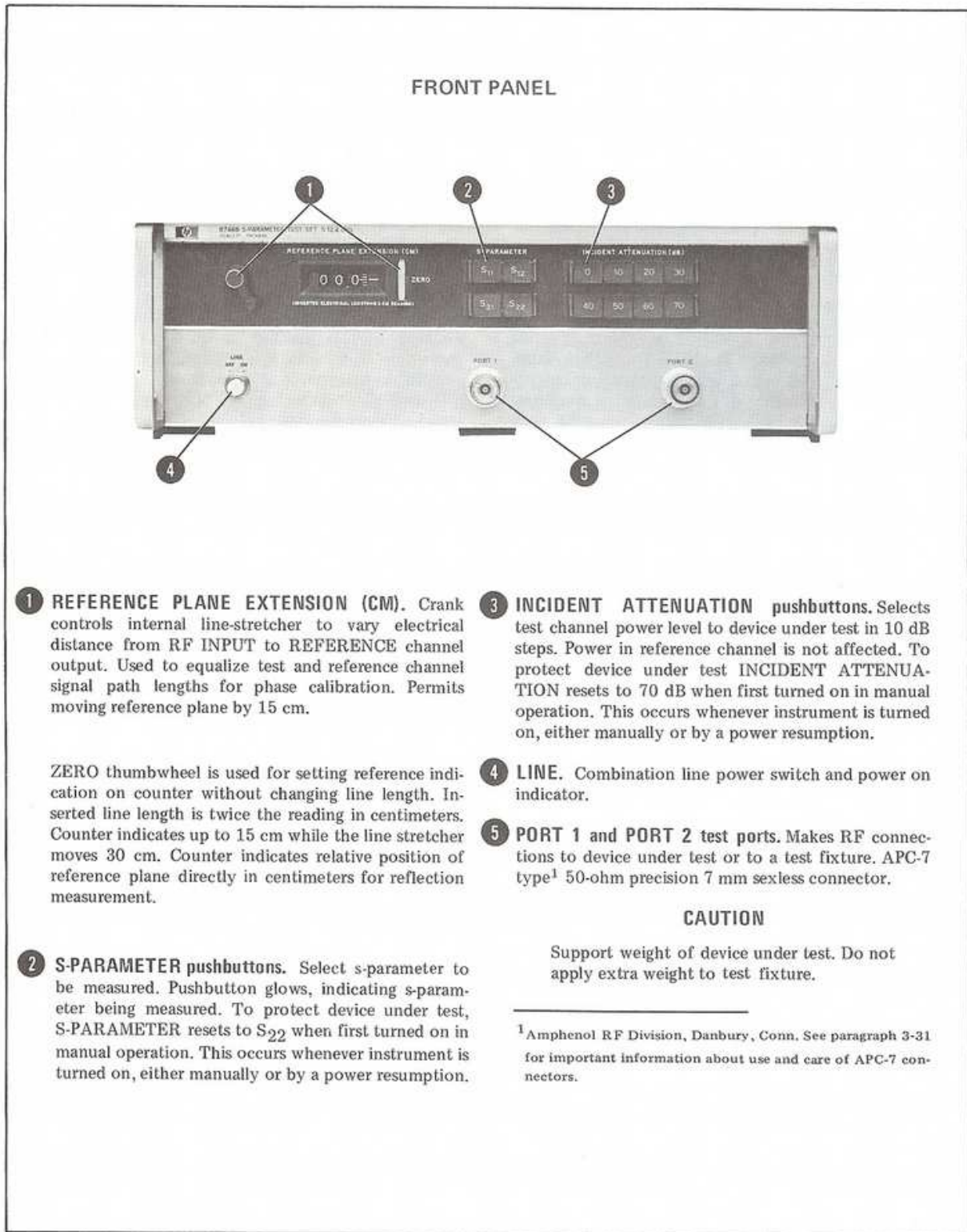

1 REFERENCE PLANE EXTENSION (CM). Crank controls internal line-stretcher to vary electrical distance from RF INPUT to REFERENCE channel output. Used to equalize test and reference channel signal path lengths for phase calibration. Permits moving reference plane by 15 cm.

ZERO thumbwheel is used for setting reference indication on counter without changing line length. Inserted line length is twice the reading in centimeters. Counter indicates up to 15 cm while the line stretcher moves 30 cm. Counter indicates relative position of reference plane directly in centimeters for reflection measurement.

2 S-PARAMETER pushbuttons. Select s-parameter to be measured. Pushbutton glows, indicating s-parameter being measured. To protect device under test, S-PARAMETER resets to S_{22} when first turned on in manual operation. This occurs whenever instrument is turned on, either manually or by a power resumption.

3 INCIDENT ATTENUATION pushbuttons. Selects test channel power level to device under test in 10 dB steps. Power in reference channel is not affected. To protect device under test INCIDENT ATTENUATION resets to 70 dB when first turned on in manual operation. This occurs whenever instrument is turned on, either manually or by a power resumption.

4 LINE. Combination line power switch and power on indicator.

5 PORT 1 and PORT 2 test ports. Makes RF connections to device under test or to a test fixture. APC-7 type¹ 50-ohm precision 7 mm sexless connector.

CAUTION

Support weight of device under test. Do not apply extra weight to test fixture.

¹Amphenol RF Division, Danbury, Conn. See paragraph 3-31 for important information about use and care of APC-7 connectors.

Figure 3-2. Front Panel Features



Figure 3-3. Rear Panel Features

HP 8746b 0.5-12.4 GHz S-parameter test-set

Operation

Model 8746B

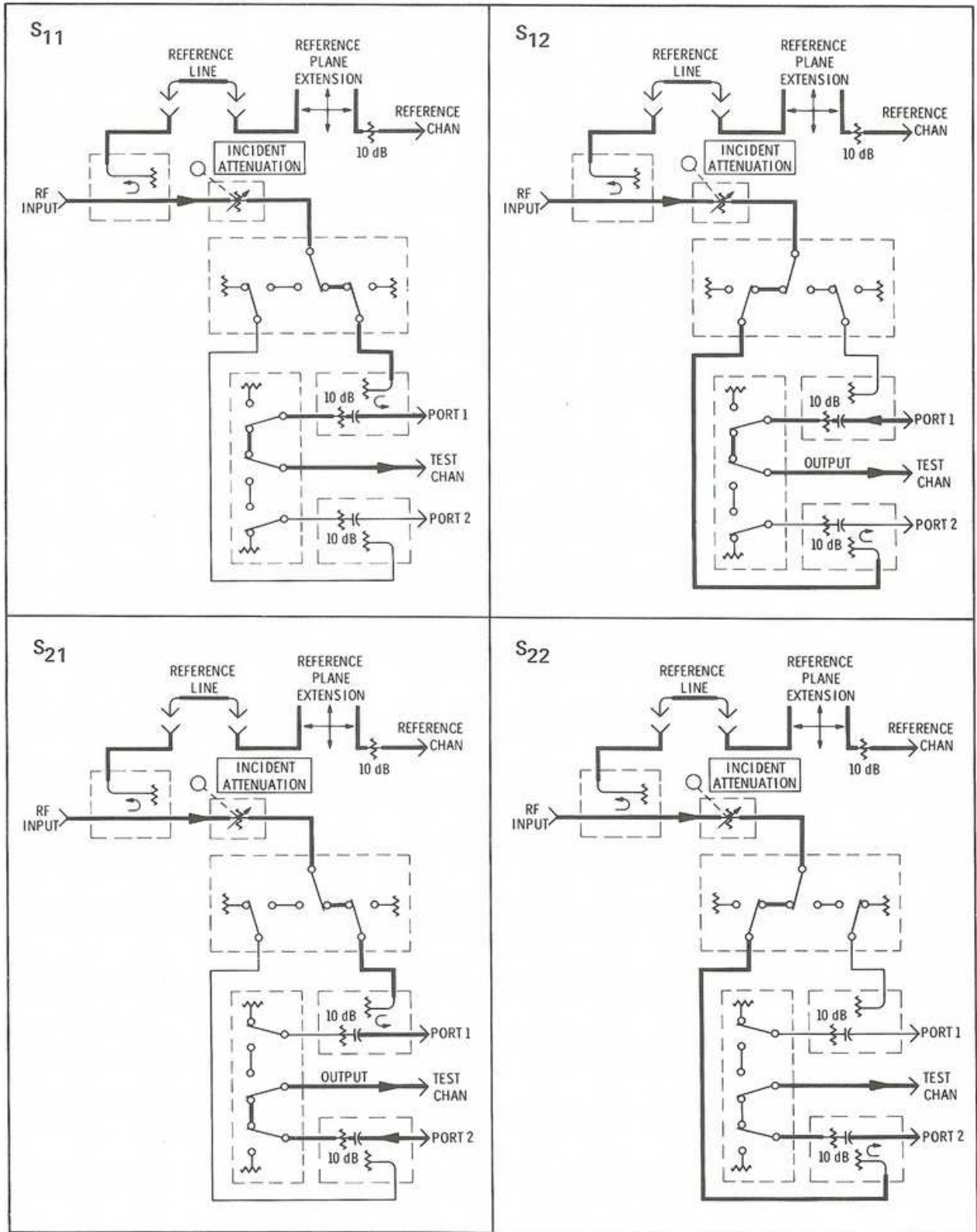

Figure 3-4. Standard Model RF Circuits

HP 8746b 0.5-12.4 GHz S-parameter test-set

Model 8746B

Operation

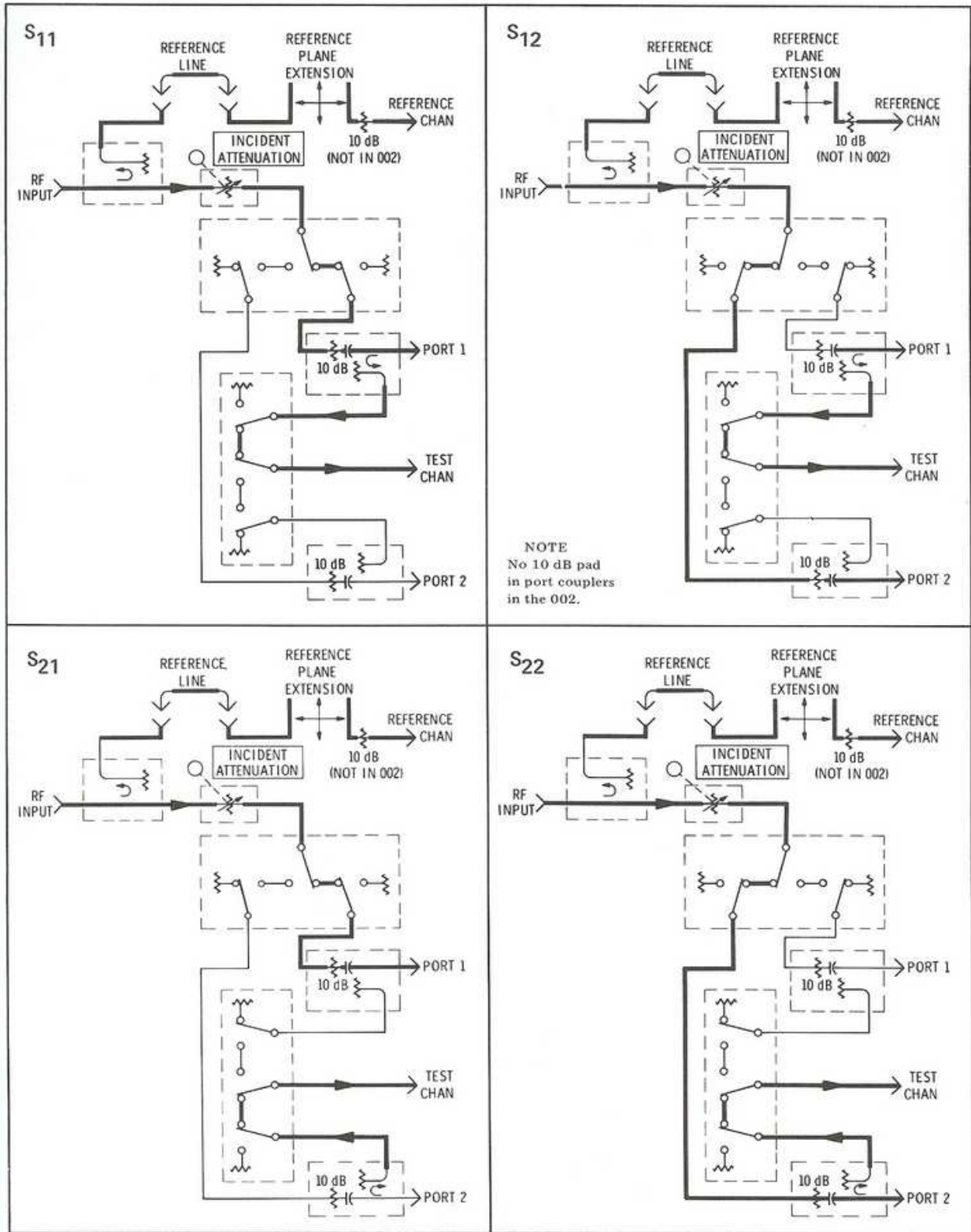

Figure 3-5. Option 001 and 002 RF Circuits

Table 3-2. If the 8717A is used, refer to its Operating and Service Manual for full details concerning operation of the 8717A. Set the front panel switches on the 8717A to correspond to the transistor to be tested. To apply bias to the transistor under test, perform the following:

CAUTION

These instructions are for bipolar transistors (PNP or NPN). Some FET transistors may be damaged by applying bias in this order, while this is the proper order for other FET's. The order of applying bias depends upon the type of FET. Therefore, always read the manufacturer's biasing instructions before testing transistors. Good practice is to try your procedure on a similar, but inexpensive transistor, first.

a. Make Bias and Bias Sense connections from 8746B to 8717A output. If the 8717A interconnect cable is not available, make up a cable

using the connector furnished with the 8746B. Normally port 1 circuit is used for the input-bias circuit and port 2 for the output-bias circuit. Direction of RF signal flow depends upon the parameter measured.

b. Set 8717A voltage METER FUNCTION switch to V_{CE-DS} position and adjust V_{CE-DS} AMPL control fully counterclockwise.

c. With no transistor or calibrator installed, turn 8717A on.

d. Adjust 8717A V_{CE-DS} AMPL control to 0.1 to 0.3 volts¹.

CAUTION

If C_{CE-DS} is set below 0.1V, base-collector junction may become forward-biased and draw excessive reverse current. This may damage the transistor under test.

¹If difficulty is found when setting 0.1 to 0.3 volts, contact your nearest Hewlett-Packard office for further information.

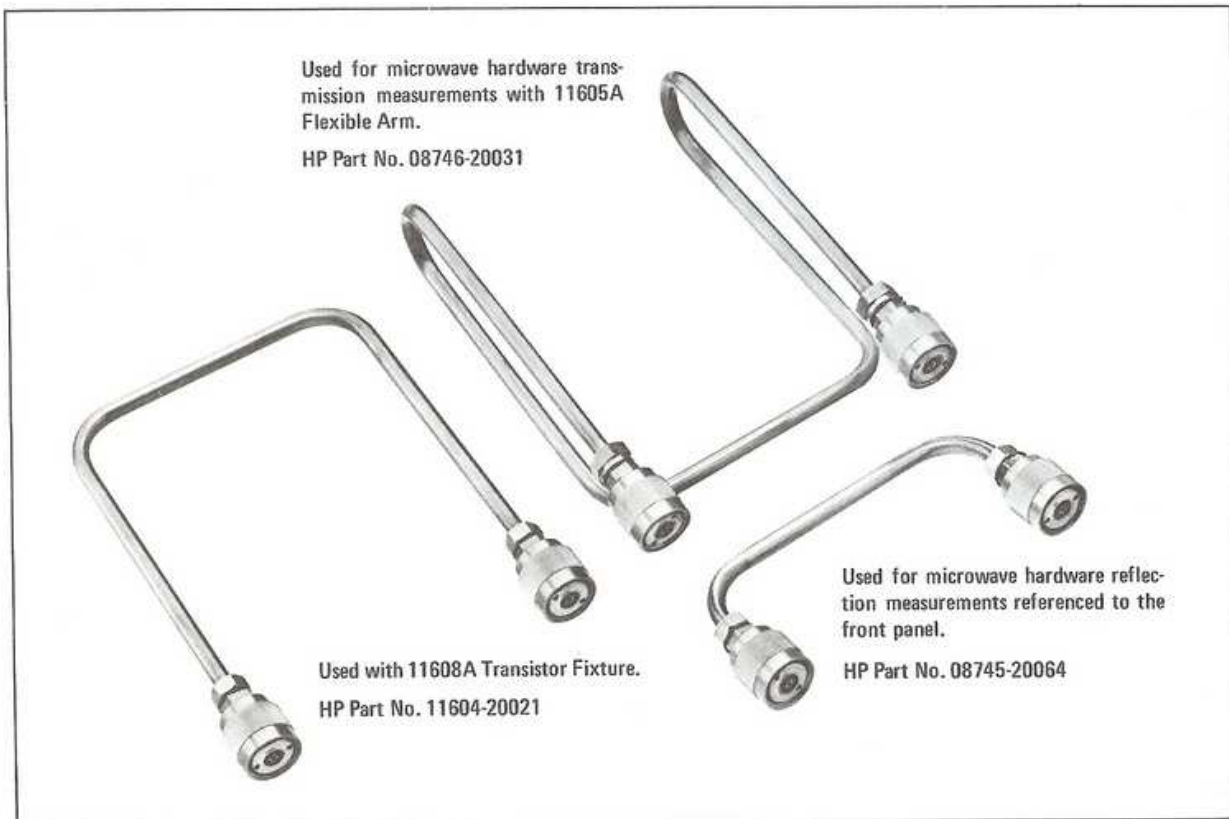

Figure 3-6. Reference Line Coaxial Patch Cables

- e. Turn the 8717A bias off.
- f. Set 8717A I_{E-S} AMPL/RANGE control fully counterclockwise.
- g. Set I_{E-S} LIMIT(MA) current-limit switch to 5, 50, or 500 mA position to protect the transistor under test.
- h. Place the transistor under test in the 11608A with the input lead to the left and the output lead to the right.
- i. Hold the transistor in contact with the stripline by closing the 11608A lid.
- j. Turn BIAS on. Adjust V_{CE} AMPL control to desired output voltage.
- k. Set current METER FUNCTION switch to monitor I_{E-S} and adjust I_{E-S} AMPL/RANGE control to desired collector current.
- l. Make transistor measurements as instructed in Figure 3-9.

CAUTION

If bias is not turned down before pushing BIAS switch to off, transients may damage sensitive transistors.

- m. Turn the I_{E-S} AMPL control fully counterclockwise.
- n. Turn V_{CE} AMPL control down to 0.1 to 0.3 volts.
- o. Turn BIAS off.

3-21. Bias Using a Dual DC Power Supply. Transistors may also be biased using a dual dc-power supply. Additional circuitry to protect the transistor under test may be needed. Protection circuits may take the form of diodes between the base and emitter and/or a series current-limiting resistor in the emitter or base lead. The particular circuit used will vary with the transistor used.

3-22. Note that the bias supplies can be connected with either the input or output circuit voltage connected to either port terminal. The input bias voltage is normally connected to the port 1 Bias and Bias Sense terminals and the output circuit voltage connected to port 2 Bias and Bias Sense terminals (see Figure 3-8). This convention will also make the normal (forward-gain) signal (S_{21}) flow from the left to right when the 11608A Transistor Fixture is used. When using the 11608A, or any other application where the bias supply can be shorted readily, the bias supply should be current-limited.

Table 3-2. Remote Input Connector Pin Functions

Pin Number	Function
1	Chassis Ground
2	Port 2 Bias (connect to output circuit bias)
3	Port 1 Bias (connect to input circuit bias)
6	Remote S-Parameter Select ("1" bit)
15	Remote Attenuation Select (10 dB bit)
16	Remote Attenuation Select (40 dB bit)
17	Remote Operation Enabling (short to pin 18 or 36)
18	Common Logic Ground
19	Chassis Ground
20	Port 2 Bias Sense (output circuit bias sensing)
21	Port 1 Bias Sense (input circuit bias sensing)
24	Remote S-Parameter Select ("2" bit)
33	Remote Attenuation Select (20 dB bit)
36	Common Logic Ground
All Others	No connection

If a greater current-carrying capacity on the Bias lead is needed, parallel the Bias and Bias Sense leads. However, remote bias-sensing may be degraded. See the following caution.

CAUTION

If the Bias Sense lead is used to carry current, its bias-sensing function will be degraded by the voltage drop due to the current flow.

3-23. Connect the power supply to the 8746B. Adjust the power supply as follows:

- a. Set both power supplies to zero volts output and turn both on.

CAUTION

Limit the current on each Bias and Bias Sense lead to 0.5 amp to avoid burning out the 1/2 amp fuse in the leads.

- b. Place the transistor to be tested in the 11608A with the input lead to the left and the output lead to the right.

- c. Hold the transistor in contact with the stripline by closing the 11608A lid.

- d. Set the supply connected to the output circuit to obtain the desired collector-emitter (drain-source) voltage. If a stabilizing resistor is used, set supply to desired voltage plus the voltage drop across the stabilizing resistor. (Do NOT use remote sensing with a stabilizing resistor.)

- e. Adjust the voltage from the supply connected to the input circuit until the desired collector (drain) current is obtained. Recheck voltage set in step d. When operating with power applied to the transistor over an extended period of time, this supply may have to be readjusted slightly to maintain the desired collector (drain) current.

- f. Make Transistor Measurements as instructed in Figure 3-9.

3-24. REMOTE OPERATION

3-25. The 36-pin connector, REMOTE INPUT, used for biasing, also provides contacts for remote selection of manual/remote operation, s-parameter selection, and incident attenuation (see Table 3-2). To use the 8746B remotely, pin 17 of J6 (REMOTE INPUT) jack must be shorted to the common (pins 18 or 36).

3-10

3-26. Remote S-Parameter Selection. In the remote mode the s-parameter selection is made by means of pins 6 and 24. Connect for the desired s-parameter as shown in Table 3-3.

Table 3-3. Remote S-Parameter Selection Truth Table

Parameter to be Measured	Pin 18 or 36 to:		Pushbutton Lit
	PIN 24	PIN 6	
S ₁₁	Open	Open	S ₁₁
S ₁₂	Open	Closed	S ₁₂
S ₂₁	Closed	Open	S ₂₁
S ₂₂	Closed	Open	S ₂₂

NOTE: Pin 17 must be shorted to common (18 or 36) to select remote operation.

Selecting remote operation enables remote s-parameter select pins 6 and 24, and disables the s-parameter pushbuttons.

3-27. Remote Attenuation Selection. The MANUAL-REMOTE switch controls operation of INCIDENT ATTENUATION pushbuttons only. When in MANUAL position, incident attenuation is selected by front-panel pushbutton only, whether pin 17 of J6 REMOTE INPUT connector is shorted to common or not. When in REMOTE position, incident attenuation is selected by front-panel pushbuttons if pin 17 is not shorted to common or by contact closures on the 36-pin connector only if pin 17 is shorted to common.

3-28. Remote Operation Requirements

3-29. The 8746B supplies approximately +12 Vdc when remote circuit is open and 12 mA of current flows when the contact is closed. Noise on the remote control lines should not exceed 2 volts peak.

Table 3-4. Remote Attenuation Selection Truth Table

Attenuation	Pin 18 or 36 to:			Pushbutton Lit
	"10 dB bit" Pin 15	"20 dB bit" Pin 33	"40 dB bit" Pin 16	
0 dB	Open	Open	Open	0 dB
10 dB	Closed	Open	Open	10 dB
20 dB	Open	Closed	Open	20 dB
30 dB	Closed	Closed	Open	30 dB
40 dB	Open	Open	Closed	40 dB
50 dB	Closed	Open	Closed	50 dB
60 dB	Open	Closed	Closed	60 dB
70 dB	Closed	Closed	Closed	70 dB

Note: Pin 17 must be shorted to common (18 or 36) and REMOTE-MANUAL switch in REMOTE to select INCIDENT ATTENUATION remotely.

3-30. OPERATOR'S MAINTENANCE

3-31. Care of APC-7 Connectors

3-32. RF connections to and from the device under test, and to phase-amplitude ratio indicator are made with APC-7 type 50-ohm, 7-mm connectors. These connectors should be handled with particular care since continuity through APC-7 connectors is obtained by end-to-end contact of the inner and outer conductors. Consequently, the electrical performance of the connector is largely dependent upon the condition of these exposed surfaces.

3-33. Important recommendations about the handling and care of the APC-7 connectors are given in Figure 3-11. The part of an input connector that is most likely to be damaged is the inner conductor contact. Since it protrudes slightly beyond the plane of electrical contact, any wiping action of one connector across the other can damage the contact enough to cause a discontinuity. The risk of this kind of damage can be minimized by always having the coupling sleeves on the input port connectors fully extended.

3-34. Replacement inner-conductor contacts are available from Hewlett-Packard (Part No. 1250-0907), and from Amphenol RF Division, Danbury, Conn. (Part No. 131-129).

3-35. Observe the following precautions when replacing an inner conductor contact:

- a. Do not disassemble the connector.
- b. Do not apply more than slight inward pressure to the inner conductor.
- c. Do not apply any twisting force to the inner conductor.

d. Do not attempt to repair contacts.

e. Do not re-use contacts.

3-36. Because of the above considerations, contact removal should NOT be attempted with ordinary hand tools. Only the Hewlett-Packard self-positioning, hypodermic-action, contact extractor tool (Part Number 5060-0236)¹ should be used. This tool exerts no appreciable inward pressure and no twisting force on the inner conductor. Instructions for removing contacts are supplied with the tool.

3-37. No tools are required to install a replacement contact. Insert the contact gently by hand, applying only enough inward pressure to snap it into place. Then check for proper installation by inspecting the contact for even spacing of its four segments. Also, test for normal spring action by applying light inward pressure against the end of the contact with a pencil eraser. As the pressure is released the contact's spring action should cause it to move outward. If not, the contact is defective and should be replaced.

3-38. The coupling mechanism of the front-panel port couplers includes the coupling nut and the two-piece coupling sleeve assembly shown in Figure 3-11. Both of these parts can be replaced using the procedures in Section VIII, Service.

3-39. Fuses

3-40. AC Line Fuse. Protection for the instrument is provided by fuse F1 located in the power module at the rear panel of the instrument. To change a fuse proceed as follows:

- 1. Remove the power cord from the power module.

¹Part of APC-7 Connector Tool Kit, HP 11591A.

2. Slide the clear plastic cover all the way to the left.
3. Remove the fuse by pulling up on the handle to the right and just below the fuse.
4. Replace the fuse with a fuse of the proper value:
 115V: 1 ampere standard-blow, HP Part Number 2110-0001
 230V: ½ ampere standard-blow, HP Part Number 2110-0012

3-41. Bias and Bias Sense Fuses. Each Bias and Bias Sense lead for each port coupler is fused with a 0.5 amp fuse. To replace these fuses proceed as follows:

1. Turn off the bias supplies.
2. Remove the front top cover of the 8746B.
3. Trace the wires from coupler involved to the fuse block.
4. Remove fuse and replace with a 1/2 amp fuse (HP Part No. 2110-0012).

3-42. Line Switch Bulb Replacement

3-43. The bulb housed in the LINE switch pushbutton indicates that line power is applied to the Model 8746B. This bulb may be replaced without unscrewing the switch retaining ring. To replace the bulb, disconnect the power cord and pull the pushbutton straight out. Figure 3-7. is an exploded view of the pushbutton/bulb assembly.

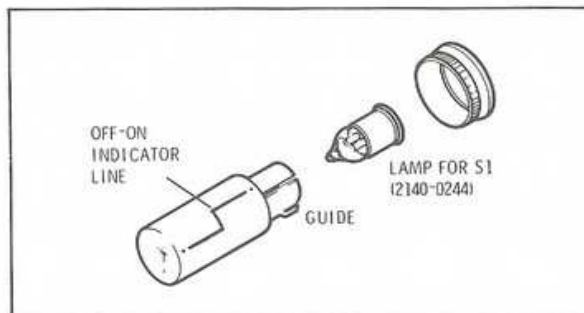

Figure 3-7. Line Switch Bulb Replacement

Remove the bulb by grasping the bulb skirt with the fingernails or a pair of long-nosed pliers and pulling while holding the pushbutton. The HP Part No. for a replacement bulb is listed under DS1 (chassis) in the Table of Replaceable Parts, Section VI. Install a replacement bulb by inserting the bulb into the pushbutton. Then insert the key in the pushbutton assembly into the slot in the switch body. Push the pushbutton assembly in until it seats.

3-44. Pushbutton Switch Bulb Replacement

3-45. Instructions for replacing the bulbs which light the s-parameter and attenuation pushbutton switches are given in Figure 3-12.

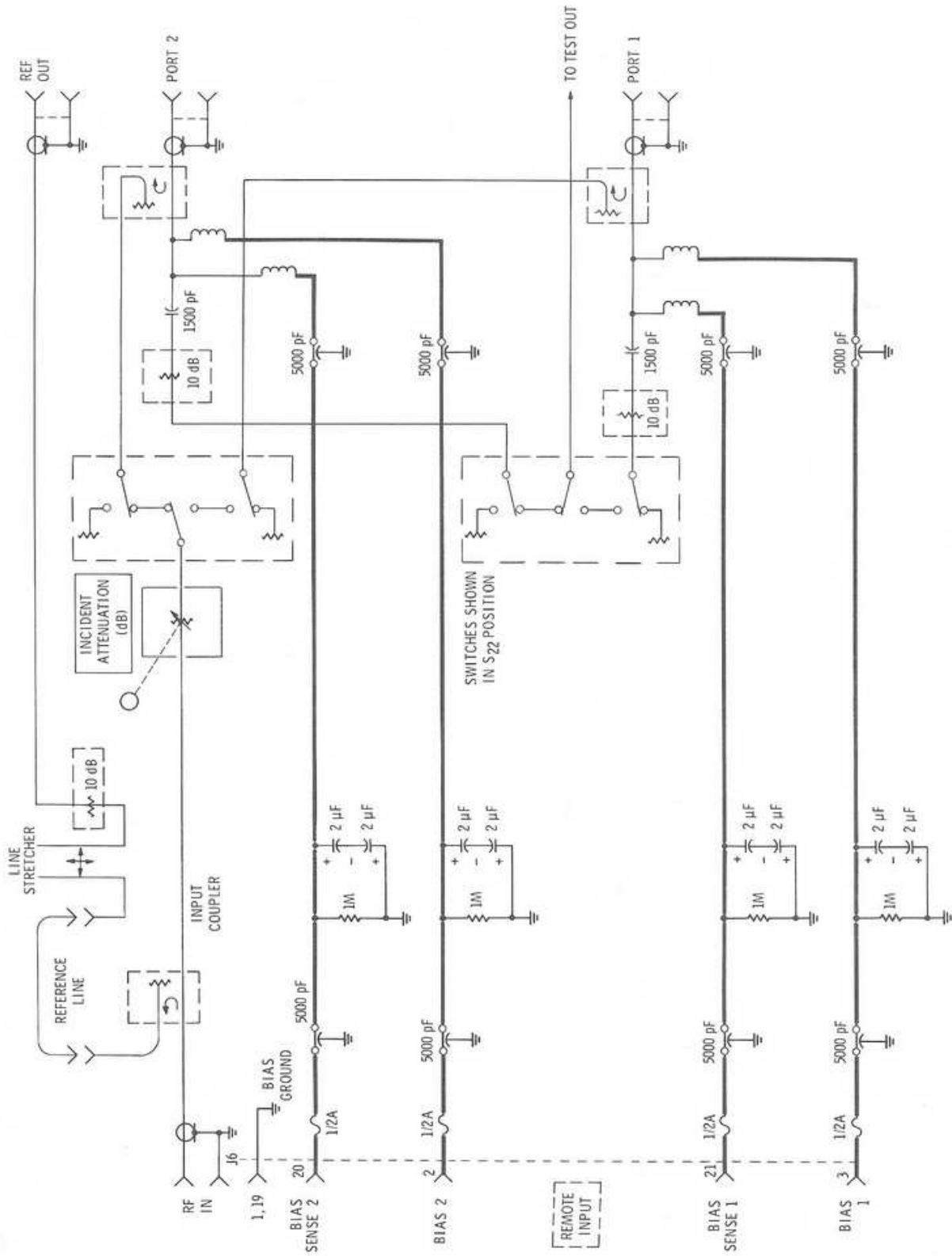

Figure 3-8. Bias Voltage Input Connections

HP 8746b 0.5-12.4 GHz S-parameter test-set

Operation

Model 8746B

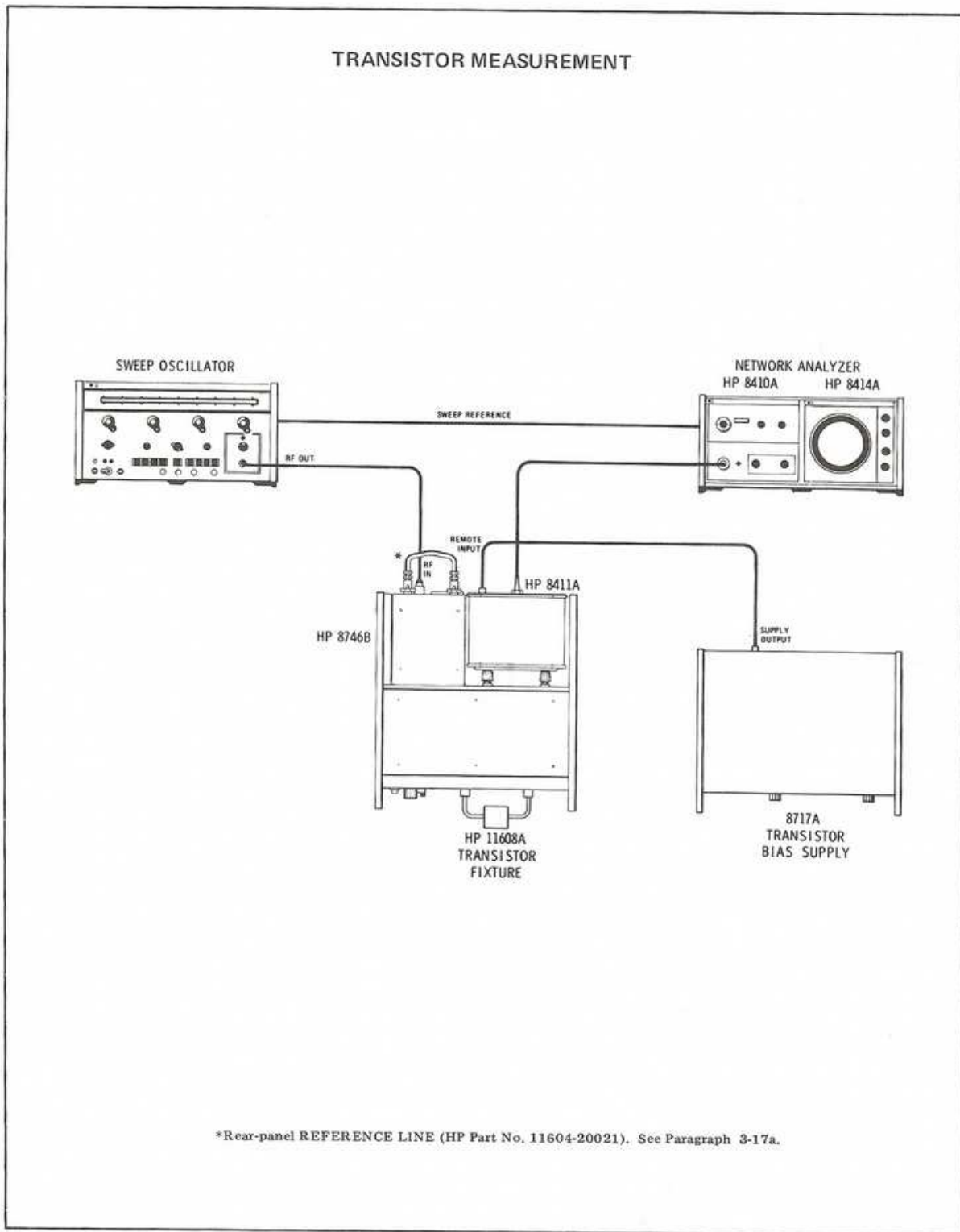

Figure 3-9. Transistor Measurement (1 of 2)

TRANSISTOR MEASUREMENT

Calibration:

1. Connect equipment as shown on previous page. **TURN BIAS OFF!** Insert shorting calibrator for reflection measurement or through-line calibrator for transmission measurements (see Table 3-1 for the corresponding display indications).
2. Select s-parameter to be measured and incident power attenuation desired by pushing appropriate 8746B pushbuttons.
3. Set the Sweep Oscillator to sweep the frequency band of interest.
4. Adjust the Sweep Oscillator and Network Analyzer controls to phase lock the Network Analyzer over the frequency band selected.
5. Adjust the Network Analyzer TEST CHANNEL GAIN and AMPLITUDE VERNIER controls for an amplitude reference on the display unit:
 - a. For 8414A adjust for a reflection or transmission coefficient of 1.0 (outer graticule circle).
 - b. For 8412A adjust for a convenient amplitude reference (preferably 0 dB).
6. Adjust 8746B REFERENCE PLANE EXTENSION to obtain equal reference and test channel electrical lengths:
 - a. For 8414A adjust for dot or smallest cluster.
 - b. For 8412A adjust for a horizontal phase trace.
7. Adjust Network Analyzer PHASE VERNIER control:
 - a. For 8414A adjust for calibrator reference (short 180 degrees, through-section 0 degrees).
 - b. For 8412A adjust for a convenient reference. (When calibrating with a short, set DEGREES control to 180 degrees. Always return to 0 degrees before making a measurement.)

Two transistor calibrators are used for calibration: a short for reflection, and a through-line for transmission. The through-line calibrator does not calibrate to the edge of the transistor case directly, as the short does. The transmission calibration reference plane is halfway between the two ports. To calibrate to the edge of the transistor case, an offsetting calibration value is given in Table 2 of the Model 11608A Operating Note.

8. For transmission calibration insert through-line calibrator. Move the reference plane to the edge of the transistor case by turning REFERENCE PLANE EXTENSION counterclockwise the amount of the off-setting calibration value. The offsetting calibration value is given in Table 2 of the Model 11608A Operating Note. This value is the calibrator overall electrical length. When using the 8746B, the change in reference channel length is twice the REFERENCE PLANE EXTENSION counter indication. Therefore, the counter indication should be changed by one-half the calibrator overall length.

Measurement:

1. Remove the calibrator from the Transistor Fixture and install transistor with output lead pointing to the right.

CAUTION

ALWAYS TURN BIAS OFF BEFORE OPENING 11608A LID. Observe operating precautions in paragraph 3-5 and avoid switching transients as described in paragraph 3-19.

2. Adjust the transistor bias. See paragraph 3-18 for instructions concerning bias-supply installation and operation.
3. Read magnitude and phase from the display indicator.

Figure 3-9. Transistor Measurement (2 of 2)

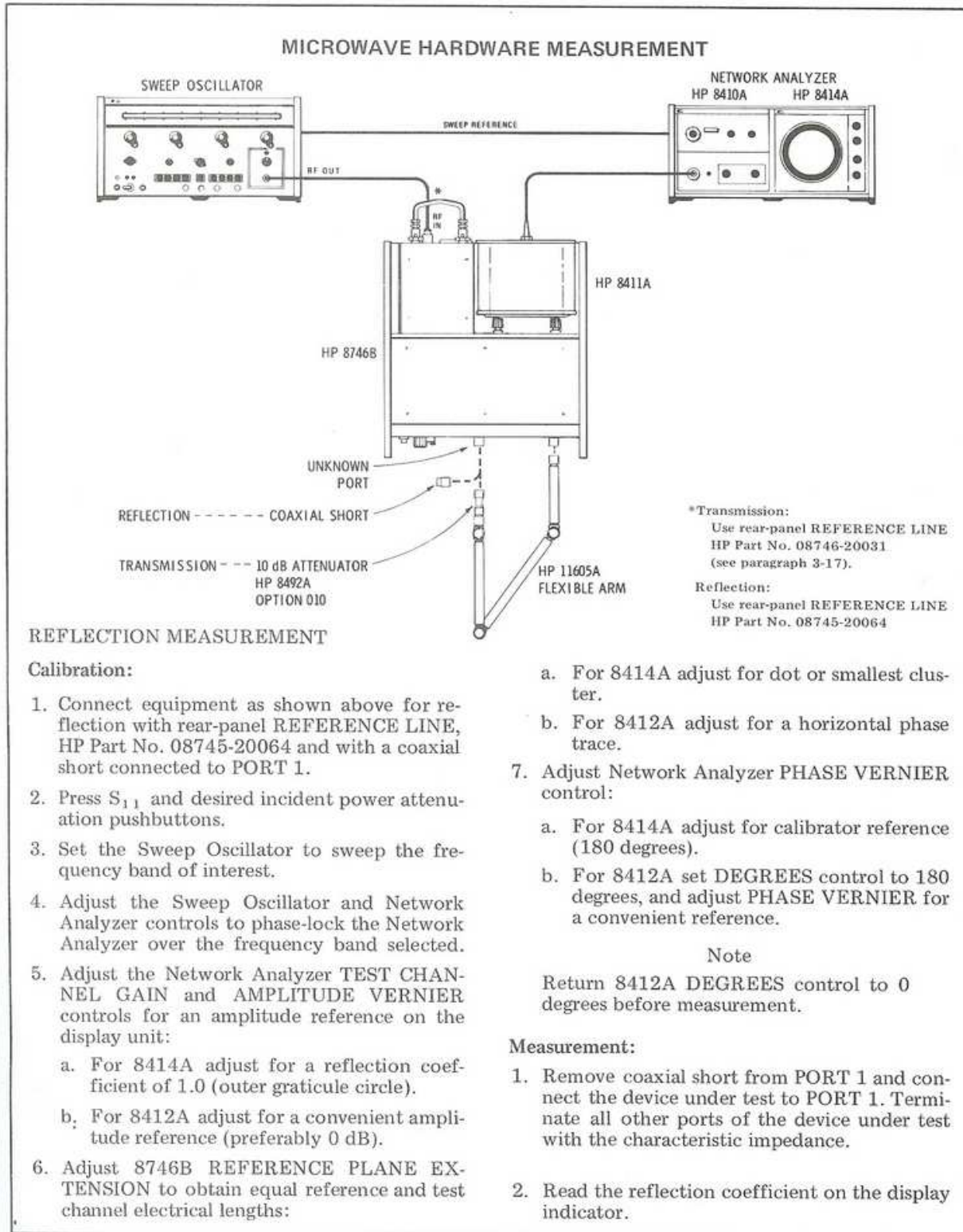

Figure 3-10. Microwave Hardware Measurement (1 of 2)

MICROWAVE HARDWARE MEASUREMENT

TRANSMISSION MEASUREMENT

Calibration:

1. Connect equipment as shown on previous page for transmission with rear-panel REFERENCE LINE, HP Part No. 08746-20031. Connect a 10-dB attenuator, such as the HP Model 8492A Option 010, to the Flexible Arm, and connect attenuator to the 8746B PORT 1.
2. Press S_{21} or S_{12} and desired incident-power attenuation pushbuttons.
3. Set the Sweep Oscillator to sweep the frequency band of interest.
4. Adjust the Sweep Oscillator and Network Analyzer controls to phase lock the Network Analyzer over the frequency band selected.
5. Adjust the Network Analyzer TEST CHANNEL GAIN and AMPLITUDE VERNIER controls for an amplitude reference on the display unit:
 - a. For 8414A adjust for a transmission coefficient of 1.0 (outer graticule circle).
 - b. For 8412A adjust for a convenient amplitude reference (preferably 0 dB).
6. Adjust 8746B REFERENCE PLANE EXTENSION to obtain equal reference and test channel electrical lengths:
 - a. For 8414A adjust for dot or smallest cluster.
 - b. For 8412A adjust for a horizontal phase trace.
7. Adjust Network Analyzer PHASE VERNIER control:
 - a. For 8414A adjust for calibrator reference (0 degrees).
 - b. For 8412A adjust for a convenient reference.

Measurement:

1. Insert the device to be tested between the 10-dB attenuator and PORT 1.
2. To determine gain or loss of the device under test, note the 8410A TEST CHANNEL GAIN setting. This is the calibration setting. Adjust the TEST CHANNEL GAIN controls:
 - a. For 8414A adjust to locate the CRT display on outer graticule circle.
 - b. For 8412A adjust to return the trace to the reference obtained during calibration.
 - c. The difference in TEST CHANNEL GAIN settings is the magnitude of the transmission gain or loss of the device under test.
3. To determine phase shift through the device under test:
 - a. For 8414A read phase shift directly from the display.
 - b. For 8412A determine phase shift by phase trace displacement from reference obtained during calibration.
4. To determine the electrical length of the device under test adjust 8746B REFERENCE PLANE EXTENSION to again obtain equal reference and test channel electrical lengths.
 - a. For 8414A adjust for dot or smallest cluster.
 - b. For 8412A adjust for a horizontal phase trace.
 - c. Multiply the change in the reference plane digital indicator by two to obtain the electrical length of the device under test.

Figure 3-10. Microwave Hardware Measurement (2 of 2)

SECTION IV PERFORMANCE TESTS

4-1. INTRODUCTION

4-2. The procedures in this section test the instrument's electrical performance using the specifications of Table 1-1 as the performance standards. All tests can be performed without access to the interior of the instrument. If only a simple operational test is needed, see the "Operator's Check" in Section III.

4-3. EQUIPMENT REQUIRED

4-4. Equipment required for the performance tests is listed in the Recommended Test Equipment

Table in Section I. Any equipment that satisfies the critical specifications given in the Table may be substituted for the recommended model.

4-5. TEST RECORD

4-6. Results of the performance tests may be tabulated on the Test Record at the end of the procedures. The Test Record lists all of the tested specifications and their acceptable limits. Test results recorded at incoming inspection can be used for comparison in periodic maintenance and troubleshooting and after repairs or adjustments.

4-7. Directivity

SPECIFICATION:

Directivity: ≥ 30 dB, 0.5 to 4.0 GHz
 ≥ 26 dB, 4.0 to 12.4 GHz

DESCRIPTION:

The 8746B under test is setup as a reflectometer by selecting S_{11} or S_{22} . The system is calibrated with a coaxial short for a reflection coefficient of 1. The short is removed and the 8746B is terminated with a sliding load. The Network Analyzer test channel gain is increased by the directivity specification value, making the calibration of the Polar Display's outer graticule circle equal to the directivity specification.

If the sliding load was a perfect termination, any energy from the coupler's reverse arm would be due only to the directivity signal. However, the termination is not perfect. Thus the indication on the Polar Display is due to the directivity signal plus the reflection from the sliding load. If an indication greater than the outer graticule circle is observed, set the Sweep Oscillator to CW at the frequency in question. Then phase (slide) the sliding load causing its reflected voltage vector to rotate around the tip of the directivity vector. The center of the circle caused by phasing the sliding load must be within the outer graticule circle.

PERFORMANCE TESTS

4-7. Directivity (cont'd)

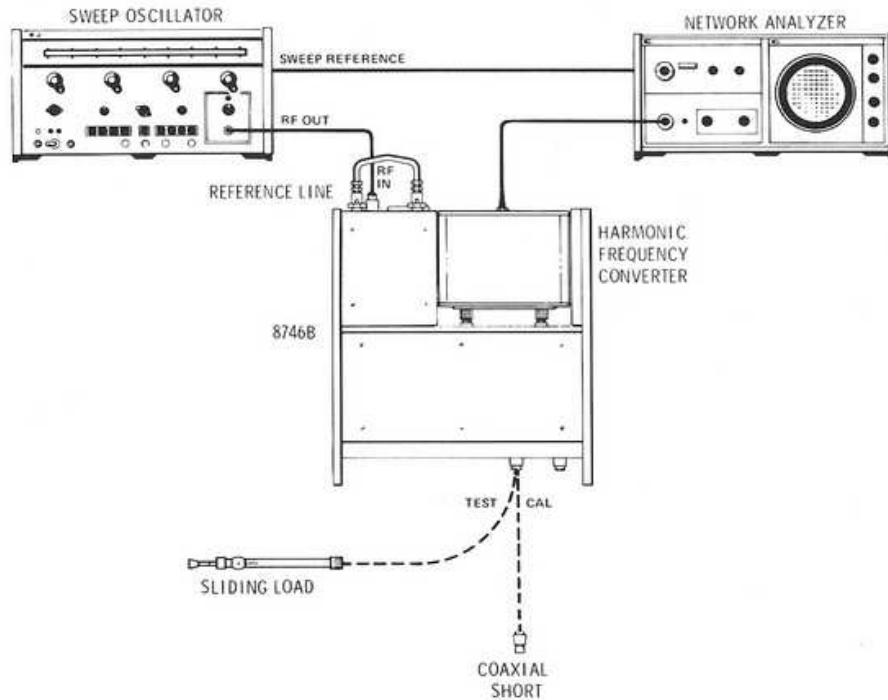

Figure 4-1. Directivity Test Setup

EQUIPMENT:

SWEEP OSCILLATOR	HP Model 8690A, B with 8691-4A, B plug in
NETWORK ANALYZER	HP Model 8410A/8414A
HARMONIC FREQUENCY CONVERTER	HP Model 8411A
SLIDING LOAD	HP Model 905A
COAXIAL SHORT	HP Model 11565A
REFERENCE LINE	HP Part No. 08745-20064

PROCEDURE:

- a. Connect the equipment as shown. Set 8746B for 0 dB attenuation. Select either PORT 1 or PORT 2 to measure. When measuring PORT 1, select S_{11} . When measuring PORT 2, select S_{22} . Connect coaxial short to port being measured.
- b. Adjust Sweep Oscillator and Network Analyzer controls to phase lock the Network Analyzer over the band of interest.
- c. Push and hold the 8414A BEAM CENTER pushbutton and adjust the horizontal and vertical position controls to place the dot in the center of the graticule.
- d. Adjust Network Analyzer TEST CHANNEL GAIN and AMPL VERNIER controls to locate the trace on the outer graticule circle.

PERFORMANCE TESTS

4-7 Directivity (cont'd)

e. Remove Coaxial Short and terminate test port being measured with a Sliding Load. Below 1.8 GHz, use HP Model 909A Option H01 Coaxial Termination.

f. Increase Network Analyzer TEST CHANNEL GAIN by 30 dB for 0.5 to 4.0 GHz or 26 dB for 4.0 to 12.5 GHz.

g. Set Sweep Oscillator to sweep very slowly across the frequency band of interest.

h. Phase the Sliding Load while observing the 8414A. The center of the circle caused by phasing the Sliding Load must be within the outer graticule circle. For frequencies below 1.8 GHz, the display of directivity plus the fixed load reflection must be within the outer graticule circle.

i. Repeat steps a through h to test directivity of the other test port.

4-8. Source Match ¹**SPECIFICATION:**

VSWR: ≤ 1.3 ($\rho = 0.13$) (when used with 8411A)
(Specification applies to standard model only.)

DESCRIPTION:

Source match is tested by measuring the change in magnitude of a maximum reflection when the phase of the reflected signal is varied. A swept-amplitude display of a maximum reflection is obtained when using a coaxial short. The displayed trace is marked on the oscilloscope with a grease pencil. The phase of the reflection is changed approximately 180° by removing the coaxial short. The displayed trace of the open circuit is also marked on the oscilloscope with a grease pencil. The maximum difference between these two traces at any frequency should be less than 2.3 dB (voltage ratio of 1.3:1).

¹Equivalent source reflection coefficient

PERFORMANCE TESTS

4-8 Source Match (cont'd)

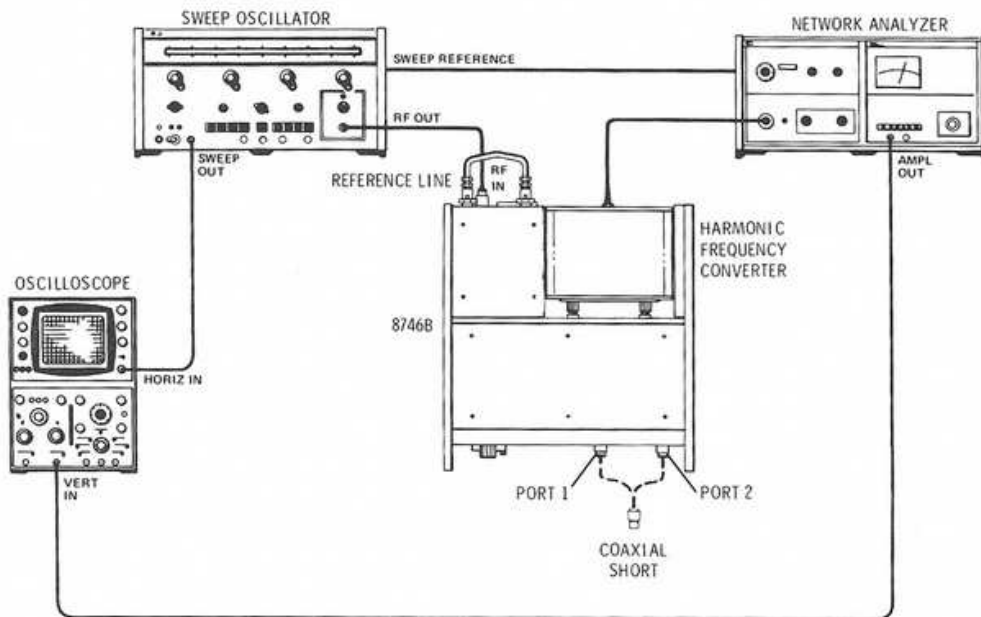

Figure 4-2. Source Match Test Setup

EQUIPMENT:

SWEEP OSCILLATOR	HP Model 8690 Series with RF unit as required
NETWORK ANALYZER	HP Model 8410A with 8413A Phase-Gain Indicator
HARMONIC FREQUENCY CONVERTER	HP Model 8411A
OSCILLOSCOPE	HP Model 180A/1801A/1821A
COAXIAL SHORT	HP Model 11561A
REFERENCE LINE	HP Part No. 08745-20064

PROCEDURE:

- a. Connect the equipment as shown. Set 8746B for 0 dB attenuation. Select either PORT 1 or PORT 2 to measure. When measuring PORT 1 select S_{11} . When measuring PORT 2 select S_{22} . Connect coaxial short to port being measured.
- b. Adjust Sweep Oscillator, Network Analyzer, and Oscilloscope controls to obtain a swept-amplitude display over the frequency band of interest.
- c. Calibrate Oscilloscope vertical sensitivity to display 1 dB/cm.

PERFORMANCE TESTS

4-8. Source Match (cont'd)

- d. Draw the Oscilloscope trace on the face of the CRT with a grease pencil.
- e. Remove the Coaxial Short and draw the trace of the open circuit on the face of CRT with a grease pencil.
- f. The maximum difference between traces at any frequency should not exceed 2.3 dB (1.3 SWR). This specification applies to the standard model 8746B only.
- g. Repeat steps a through f for other frequency segments as necessary to cover the range of 0.5 to 12.4 GHz.
- h. Repeat steps a through g to test source match of the other test port.

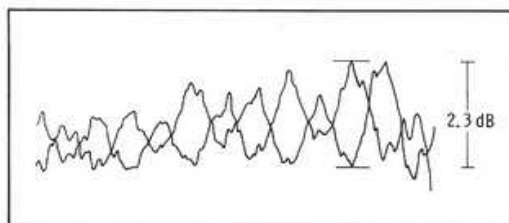

4-9. Return Match¹

SPECIFICATION:
 VSWR: ≤ 1.3 ($\rho = 0.13$)
 (Specification applies to standard model only.)

DESCRIPTION:
 Return match of each test port is tested using the internal coupler associated with the other test port in a reflectometer setup canceling, at single frequencies, the coupler directivity and Flexible Arm reflections.

¹Reflection coefficient of port used to terminate device under test.

PERFORMANCE TESTS

4-9. Return Match (cont'd)

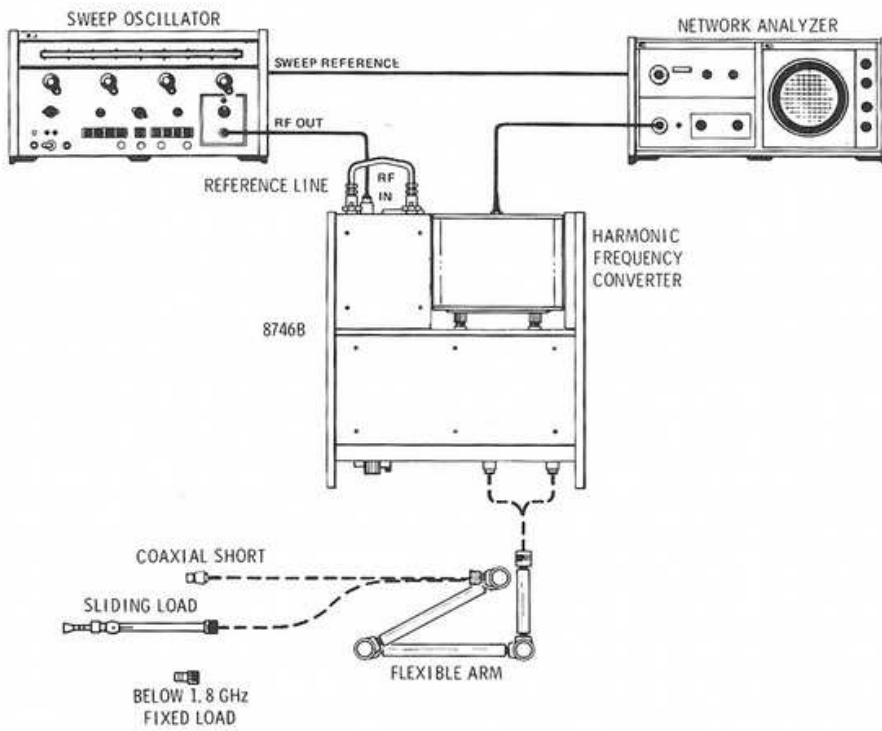

Figure 4-3. Return Match Test Setup

EQUIPMENT:

SWEEP OSCILLATOR	HP Model 8690 Series with RF unit as required
NETWORK ANALYZER	HP Model 8410A with 8414A Display Unit
HARMONIC FREQUENCY CONVERTER	HP Model 8411A
FLEXIBLE ARM	HP Model 11605A
COAXIAL SHORT	HP Model 11565A
SLIDING LOAD	HP Model 905A (Below 1.8 GHz use HP Model 909A Option H01 Coaxial Termination.)
REFERENCE LINE	HP Part No. 08746-20031

PROCEDURE:

- a. Connect the equipment as shown. Set 8746B for 0 dB attenuation. Select either PORT 1 or PORT 2 to measure.
 1. When measuring PORT 1 return match, connect long section of the Flexible Arm to PORT 2 and Select S_{22} .
 2. When measuring PORT 2 return match, connect long section of the Flexible Arm to PORT 1 and select S_{11} .

PERFORMANCE TESTS

4-9. Return Match (cont'd)

- b. Connect a coaxial short to the free end of the Flexible Arm.
- c. Adjust Sweep Oscillator and Network Analyzer controls to phase lock the Network Analyzer over the frequency band of interest.
- d. Push and hold the 8414A BEAM CENTER pushbutton and adjust the horizontal and vertical position controls to place the dot in the center of the graticule.
- e. Adjust Network Analyzer TEST CHANNEL GAIN and AMPL VERNIER controls to locate the trace on the outer graticule circle. If the trace deviates from a circle by more than 5 mm, narrow the frequency range being swept.
- f. Remove the coaxial short and connect the free end of the Flexible Arm to the port being measured.
- g. Increase Network Analyzer TEST CHANNEL GAIN by 18 dB (This specification applies to the standard model 8746B only.) The polar display of reflection coefficient should be within the outer circle. If the reflection coefficient does not meet specifications, separate the Flexible Arm reflection and coupler directivity from the 8746B reflection coefficient as follows:
 1. Set the Sweep Oscillator to CW and select the frequency which corresponds to the point of greatest reflection on the Polar Display.
 2. Disconnect Flexible Arm from the port being measured.
 3. Connect a Sliding Load to the Flexible Arm. Below 1.8 GHz use 909A Option H68 Coaxial Termination. While phasing the Sliding Load and without pressing BEAM CENTER pushbutton, adjust the Polar Display vertical and horizontal position controls to place the center of the circle caused by phasing the Sliding Load in the center of the CRT graticule. Below 1.8 GHz, place the dot indication in the center of the CRT graticule.
 4. Disconnect the Sliding Load (or termination) and connect Flexible Arm to the port being measured. The display of reflection coefficient should be within the outer graticule circle.
- i. Repeat steps a through h for other frequency segments as necessary to cover the range of 0.5 to 12.4 GHz.
- j. Repeat steps a through i to test return match of the other test port.

HP 8746b 0.5-12.4 GHz S-parameter test-set

Performance Tests

Model 8746B

Table 4-1. Performance Test Record

Hewlett-Packard Model 8746B S-Parameter Test Set		Test Performed by _____ Date _____		
Serial No. _____				
Paragraph No.	Test	Minimum	Results Actual	Maximum
4-7	Directivity: 0.5 to 4.0 GHz 4.0 to 12.4 GHz	30 dB 26 dB	_____ _____	
4-8	Source Match in voltage ratio (Standard model only)		_____	2.3 dB
4-9	Return Match in return loss (Standard model only)	18 dB	_____	

4-8

SECTION V ADJUSTMENTS

5-1. INTRODUCTION

5-2. This section provides instructions for adjusting the 8746B. The following adjustments can be performed separately. The order of the power supply voltage adjustments are not important. However, the ac voltage input to the 8746B must be within 48 to 440 Hz when this adjustment is made. No appreciable warmup is necessary. Location of the voltage adjustments will be found on Service Sheet 6.

5-3. EQUIPMENT REQUIRED

5-4. Equipment required for adjustments is listed in the Recommended Test Equipment Table in Section I. Equipment for adjustment is marked "A" in the Use column.

5-5. ELECTRICAL ADJUSTMENTS

5-6. The only electrical adjustments are power supply output voltages. The adjustment locations

are shown on Service Sheet 6 (last foldout sheet in manual). With an ac input voltage of 115V/230V $\pm 10\%$, 48 to 440 Hz, proceed as follows.

a. Connect voltmeter to test points A1TP1 and A1TP3 with positive lead going to A1TP1. Adjust A1R14 (+25V ADJ) for a voltage of +25V $\pm 0.5V$.

b. Connect voltmeter to test points A1TP2 and A1TP3 with negative lead going to A1TP2. Adjust A1R17 (-25V ADJ) for a voltage of -25V $\pm 0.5V$.

5-7. MECHANICAL ADJUSTMENTS

5-8. The only mechanical adjustment is the digital counter friction clutch. To adjust this friction clutch, refer to Figure 5-1.

FRICION CLUTCH ADJUSTMENT

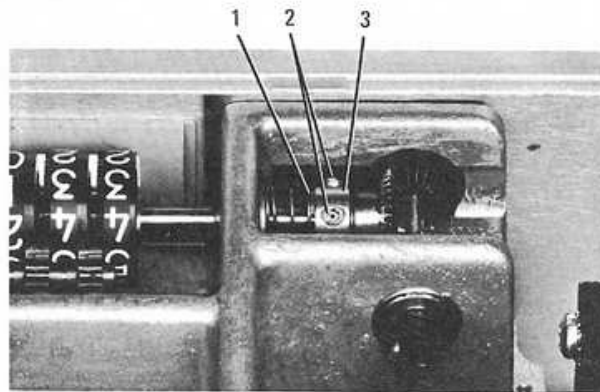

1. Remove the 8746B top cover.
2. Loosen the two hollow hex-head screws (2) holding the collar (1) in position on the shaft.
3. Hold the collar tightly against the spring washer (3) flattening the washer, while tightening the hollow hex-head screws (2).
4. Check the operation of the clutch as follows:
 - a. Adjust the REFERENCE PLANE EXTENSION crank until counter reads all zeros.
 - b. Hold thumbwheel to retain zero indication and rotate the crank counterclockwise until the stop is reached. Release the thumbwheel.
 - c. Rotate the crank clockwise until the stop is reached. The dial should indicate 15 cm or greater.
 - d. Rotate the crank counterclockwise until the stop is reached. The counter dial should indicate all zeros again. If the dial does not indicate all zeros, readjust the friction clutch and repeat this check.

Figure 5-1. Digital Counter Friction Clutch Adjustment

SECTION VI REPLACEABLE PARTS

6-1. INTRODUCTION

6-2. This section contains information for ordering replaceable parts. The step attenuator assembly A6 is available as either a new or a rebuilt assembly. Exchange assemblies afford considerable cost saving, but are available only on a trade-in basis. A repairable assembly is required in exchange for each factory-repaired and tested reuseable assembly.¹

6-3. Table 6-1 gives the meanings of the abbreviations and reference designations used in the table of replaceable parts.

6-4. Table 6-2 is the table of replaceable parts, and is organized as follows:

- a. Electrical assemblies and their components in alpha-numerical order by reference designation.
- b. Chassis-mounted parts in alpha-numerical order by reference designation.
- c. Miscellaneous parts.
- d. Illustrated assembly drawings as follows:

Figure 6-1, Model 8746B Front Panel Assembly

Figure 6-2, Front Panel Assembly

Figure 6-3 through 6-5 show replaceable parts of all interface connectors except RF IN (DC3J1). The RF IN connector is part of a directional coupler and is not separately replaceable.

The information given for each part consists of:

- a. The Hewlett-Packard part number,
- b. total quantity (Qty) in the instrument,

- c. description of the part,
- d. typical manufacturer of the part in a 5-digit code, and
- e. the manufacturer's number for the part.

Total quantity for each part is given only once — at the first appearance of the part number.

6-5. Table 6-3 contains the names and addresses that correspond to the manufacturers' code numbers.

6-6. ORDERING INFORMATION

6-7. To order a part listed in the Replaceable Parts Table, provide the nearest Hewlett-Packard office with the following information:

- a. The Hewlett-Packard Part No. from the Replaceable Parts table.
- b. The quantity required.

6-8. To order a part not listed in the Replaceable Parts table, provide the nearest Hewlett-Packard office with the following information:

- a. Instrument model number.
- b. Complete serial number, including prefix.
- c. Description and function of part.
- d. Quantity required.

¹When ordering extra assemblies for spare parts stock, use new assembly part number only. Exchange assemblies require trade-ins.

HP 8746b 0.5-12.4 GHz S-parameter test-set

Replaceable Parts

Model 8746B

Table 6-1. Reference Designators and Abbreviations Used in Parts List

REFERENCE DESIGNATORS							
<p>A = assembly B = motor BT = battery C = capacitor CP = coupler CR = diode DC = directional coupler DL = delay line DS = device signaling (lamp) E = misc electronic part</p>	<p>F = fuse FL = Filter J = jack K = relay L = inductor LS = loud speaker M = meter MK = microphone MP = mechanical part</p>	<p>P = plug Q = transistor R = resistor RT = thermistor S = switch T = transformer TB = terminal board TP = test point U = integrated circuit</p>	<p>V = vacuum tube, neon bulb, photocell, etc. VR = voltage regulator W = cable X = socket Y = crystal Z = tuned cavity, network</p>				
ABBREVIATIONS							
<p>A = amperes AFC = automatic frequency control AMPL = amplifier BFO = beat frequency oscillator BE CU = beryllium copper BH = binder head BP = bandpass BRS = brass BWO = backward wave oscillator CCW = counterclockwise CER = ceramic CMO = cabinet mount only COEF = coefficient COM = common COMP = composition COMPL = complete CONN = connector CP = cadmium plate CRT = cathode-ray tube CW = clockwise DEPC = deposited carbon drive DR = drive ELECT = electrolytic ENCAP = encapsulated EXT = external F = farads FH = flat head FIL H = Fillister head FXD = fixed G = giga (10⁹) GE = germanium GL = glass GRD = ground(ed)</p>	<p>H = henries HDW = hardware HEX = hexagonal HG = mercury HR = hour(s) Hz = Hertz IF = intermediate freq IMPG = impregnated INCD = incandescent INCL = include(s) INS = insulation(ed) INT = internal K = kilo = 1000 LH = left hand LIN = linear taper LK WASH = lock washer LOG = logarithmic taper LPF = low pass filter M = milli = 10⁻³ MEG = meg = 10⁶ MET FLM = metal film MET OX = metallic oxide MFR = manufacturer MHz = mega Hertz MINAT = miniature MOM = momentary MOS = metalized substrate MTG = mounting MY = "mylar" N = nano (10⁻⁹) N/C = normally closed NE = neon NI PL = nickel plate</p>	<p>N/O = normally open NOM = nominal NPO = negative positive zero (zero temperature coefficient) NPN = negative-positive-negative NRFR = not recommended for field replacement NSR = not separately replaceable OBD = order by description OH = oval head OX = oxide P = peak PC = printed circuit PF = picofarads = 10⁻¹² farads PH BRZ = phosphor bronze PHL = Phillips PIV = peak inverse voltage PNP = positive-negative-positive P/O = part of POLY = polystrene PORC = porcelain POS = position(s) POT = potentiometer PP = peak-to-peak PT = point PWV = peak working voltage RECT = rectifier RF = radio frequency RH = round head or right hand</p>	<p>RMO = rack mount only RMS = root-mean square RWV = reverse working voltage S-B = slow-blow SCR = screw SE = selenium SECT = section(s) SEMICON = semiconductor SI = silicon SIL = silver SL = slide SPG = spring SPL = special SST = Stainless steel SR = split ring STL = steel TA = tantalum TD = time delay TGL = toggle THD = thread TI = titanium TOL = tolerance TRIM = trimmer TWT = traveling wave tube μ = micro = 10⁻⁶ VAR = variable VDCW = dc working volts W/ = with W = watts WIV = working inverse voltage WW = wirewound W/O = without</p>				

HP 8746b 0.5-12.4 GHz S-parameter test-set

Model 8746B

Replaceable Parts

Table 6-2. Replaceable Parts

Reference Designation	HP Part Number	Qty	Description	Mfr Code	Mfr Part Number
A1	08746-60052	1	BOARD ASSY:POWER SUPPLY	28480	08746-60052
A1C1	0160-3451	2	C:FxD CER 0.01 UF +80-20% 100VDCW	56289	C0238101F1C3ZS25-CDH
A1C2	0160-3451		C:FxD CER 0.01 UF +80-20% 100VDCW	56289	C0238101F1C3ZS25-CDH
A1C3	0180-0141	2	C:FxD ELECT 50 UF +75-10% 50VDCW	56289	30D506G0500D2-OSM
A1C4	0180-0141		C:FxD ELECT 50 UF +75-10% 50VDCW	56289	30D506G0500D2-OSM
A1CR1	1901-0029	6	DIODE:SILICON 600 PIV	28480	1901-0029
A1CR2	1901-0029		DIODE:SILICON 600 PIV	28480	1901-0029
A1CR3	1901-0029		DIODE:SILICON 600 PIV	28480	1901-0029
A1CR4	1901-0029		DIODE:SILICON 600 PIV	28480	1901-0029
A1CR5	1902-3193	2	DIODE BREAKDOWN:13.3V 5%	28480	1902-3193
A1CR6	1902-3193		DIODE BREAKDOWN:13.3V 5%	28480	1902-3193
A1CR7	1901-0029		DIODE:SILICON 600 PIV	28480	1901-0029
A1CR8	1901-0029		DIODE:SILICON 600 PIV	28480	1901-0029
A1Q1	1853-C020	23	TSTR:SI PNP(SELECTED FROM 2N3702)	28480	1853-C020
A1Q2	1853-0050	1	TSTR:SI PNP	28480	1853-0050
A1Q3	1853-C012	8	TSTR:SI PNP	80131	2N2904A
A1Q4	1853-0052	1	TSTR:SI PNP	80131	2N3740
A1Q5	1854-C071	30	TSTR:SI NPN(SELECTED FROM 2N3704)	28480	1854-C071
A1Q6	1854-0071		TSTR:SI NPN(SELECTED FROM 2N3704)	28480	1854-C071
A1Q7	1854-0039	9	TSTR:SI NPN	80131	2N3053
A1Q8	1854-C072	1	TSTR:SI NPN	80131	2N3054
A1R1	0764-0016	2	R:FxD MET FLM 1000 OHM 5% 2W	28480	0764-0016
A1R2	0764-0016		R:FxD MET FLM 1000 OHM 5% 2W	28480	0764-0016
A1R3	0698-3640	2	R:FxD MET OX 1.8K OHM 5% 2W	28480	0698-3640
A1R4	0757-C346	2	R:FxD MET FLM 10 OHM 1% 1/8W	28480	0757-C346
A1R5	0757-0346		R:FxD MET FLM 10 OHM 1% 1/8W	28480	0757-C346
A1R6	0698-3640		R:FxD MET OX 1.8K OHM 5% 2W	28480	0698-3640
A1R7	0757-C421	2	R:FxD MET FLM 825 OHM 1% 1/8W	28480	0757-C421
A1R8	0757-C199	2	R:FxD MET FLM 21.5K OHM 1% 1/8W	28480	0757-C199
A1R9	0757-C199		R:FxD MET FLM 21.5K OHM 1% 1/8W	28480	0757-C199
A1R10	0757-C421		R:FxD MET FLM 825 OHM 1% 1/8W	28480	0757-C421
A1R11	0811-1552	1	R:FxD WW 0.56 OHM 5% 2W	28480	0811-1552
A1R12	0813-0029	1	R:FxD WW 1 OHM 3% 3W	28480	0813-0029
A1R13	0698-3154	2	R:FxD MET FLM 4.22K OHM 1% 1/8W	28480	0698-3154
A1R14	2100-1758	2	R:VAR WW 1K OHM 5% TYPE V 1W	28480	2100-1758
A1R15	0757-0438	2	R:FxD MET FLM 5.11K OHM 1% 1/8W	28480	0757-0438
A1R16	0757-0438		R:FxD MET FLM 5.11K OHM 1% 1/8W	28480	0757-0438
A1R17	2100-1758		R:VAR WW 1K OHM 5% TYPE V 1W	28480	2100-1758
A1R18	0698-3154		R:FxD MET FLM 4.22K OHM 1% 1/8W	28480	0698-3154
A2	08746-60050	1	BOARD ASSY:BUFFER	28480	08746-60050
A2C1	0180-1747	1	C:FxD ELECT 150 UF 20% 15VDCW	28480	0180-1747
A2C2	0180-1714	1	C:FxD ELECT 330 UF 10% 6VDCW	28480	0180-1714
A2CR1	1901-0025	38	DIODE:SILICON 100MA/1V	07263	FD 2387
A2CR2	1902-0041	13	DIODE:BREAKDOWN 5.11V 5%	04713	SZ10939-98
A2CR3	1901-0025		DIODE:SILICON 100MA/1V	07263	FD 2387
A2CR4	1902-0041		DIODE:BREAKDOWN 5.11V 5%	04713	SZ10939-98
A2CR5	1901-0025		DIODE:SILICON 100MA/1V	07263	FD 2387
A2CR6	1901-0025		DIODE:SILICON 100MA/1V	07263	FD 2387
A2CR7	1902-0041		DIODE:BREAKDOWN 5.11V 5%	04713	SZ10939-98
A2CR8	1901-0025		DIODE:SILICON 100MA/1V	07263	FD 2387
A2CR9	1901-0025		DIODE:SILICON 100MA/1V	07263	FD 2387
A2CR10	1902-0041		DIODE:BREAKDOWN 5.11V 5%	04713	SZ10939-98
A2CR11	1901-0025		DIODE:SILICON 100MA/1V	07263	FD 2387
A2CR12	1901-0025		DIODE:SILICON 100MA/1V	07263	FD 2387
A2CR13	1901-0025		DIODE:SILICON 100MA/1V	07263	FD 2387
A2CR14	1902-0041		DIODE:BREAKDOWN 5.11V 5%	04713	SZ10939-98
A2CR15	1901-0025		DIODE:SILICON 100MA/1V	07263	FD 2387
A2CR16	1901-0025		DIODE:SILICON 100MA/1V	07263	FD 2387
A2CR17	1902-0041		DIODE:BREAKDOWN 5.11V 5%	04713	SZ10939-98
A2CR18	1901-0025		DIODE:SILICON 100MA/1V	07263	FD 2387
A2CR19	1901-0025		DIODE:SILICON 100MA/1V	07263	FD 2387
A2CR20	1901-0025		DIODE:SILICON 100MA/1V	07263	FD 2387
A2CR21	1902-0041		DIODE:BREAKDOWN 5.11V 5%	04713	SZ10939-98
A2CR22	1901-0025		DIODE:SILICON 100MA/1V	07263	FD 2387
A2CR23	1901-0025		DIODE:SILICON 100MA/1V	07263	FD 2387
A2CR24	1901-0025		DIODE:SILICON 100MA/1V	07263	FD 2387
A2CR25	1902-0041		DIODE:BREAKDOWN 5.11V 5%	04713	SZ10939-98
A2CR26	1902-0025	2	DIODE:BREAKDOWN:10.0V 5% 400 MW	28480	1902-0025
A2CR27	1901-0025		DIODE:SILICON 100MA/1V	07263	FD 2387
A2CR28	1901-0025		DIODE:SILICON 100MA/1V	07263	FD 2387
A2CR29	1901-0025		DIODE:SILICON 100MA/1V	07263	FD 2387
A2CR30	1902-3182	1	DIODE BREAKDOWN:SILICON 12.1V 5%	28480	1902-3182
A2CR31	1902-0049	1	DIODE:BREAKDOWN 6.19V 5%	04713	SZ10939-122
A2CR32	1902-0041		DIODE:BREAKDOWN 5.11V 5%	04713	SZ10939-98
A2Q1	1854-C071		TSTR:SI NPN(SELECTED FROM 2N3704)	28480	1854-C071

See introduction to this section for ordering information

HP 8746b 0.5-12.4 GHz S-parameter test-set

Replaceable Parts

Model 8746B

Table 6-2. Replaceable Parts

Reference Designation	HP Part Number	Qty	Description	Mfr Code	Mfr Part Number
A2Q2	1853-C020		TSTR:SI PNP(SELECTED FROM 2N3702)	28480	1853-0020
A2Q3	1854-C071		TSTR:SI NPN(SELECTED FROM 2N3704)	28480	1854-C071
A2Q4	1853-C020		TSTR:SI PNP(SELECTED FROM 2N3702)	28480	1853-0020
A2Q5	1854-C071		TSTR:SI NPN(SELECTED FROM 2N3704)	28480	1854-C071
A2Q6	1853-C020		TSTR:SI PNP(SELECTED FROM 2N3702)	28480	1853-0020
A2Q7	1854-C071		TSTR:SI NPN(SELECTED FROM 2N3704)	28480	1854-C071
A2Q8	1853-C020		TSTR:SI PNP(SELECTED FROM 2N3702)	28480	1853-0020
A2Q9	1854-C071		TSTR:SI NPN(SELECTED FROM 2N3704)	28480	1854-C071
A2Q10	1853-C020		TSTR:SI PNP(SELECTED FROM 2N3702)	28480	1853-0020
A2Q11	1854-C071		TSTR:SI NPN(SELECTED FROM 2N3704)	28480	1854-C071
A2Q12	1853-C020		TSTR:SI PNP(SELECTED FROM 2N3702)	28480	1853-0020
A2Q13	1854-C071		TSTR:SI NPN(SELECTED FROM 2N3704)	28480	1854-C071
A2Q14	1853-C020		TSTR:SI PNP(SELECTED FROM 2N3702)	28480	1853-0020
A2Q15	1854-C071		TSTR:SI NPN(SELECTED FROM 2N3704)	28480	1854-C071
A2Q16	1853-C020		TSTR:SI PNP(SELECTED FROM 2N3702)	28480	1853-0020
A2Q17	1854-C071		TSTR:SI NPN(SELECTED FROM 2N3704)	28480	1854-C071
A2Q18	1854-C071		TSTR:SI NPN(SELECTED FROM 2N3704)	28480	1854-C071
A2Q19	1854-C071		TSTR:SI NPN(SELECTED FROM 2N3704)	28480	1854-C071
A2Q20	1854-C071		TSTR:SI NPN(SELECTED FROM 2N3704)	28480	1854-C071
A2Q21	1854-C071		TSTR:SI NPN(SELECTED FROM 2N3704)	28480	1854-C071
A2Q22	1854-0062	1	TSTR:SI NPN	28480	1854-C071
A2Q22	1205-0048	1	HEAT SINK:FINNED, FOR TO-8 CASE	80131	2N1701
A2Q23	1853-C012		TSTR:SI PNP	05820	213-CB
A2Q24	1854-C039		TSTR:SI PNP	80131	2N2904A
A2Q25	1854-C071		TSTR:SI NPN(SELECTED FROM 2N3704)	80131	2N3053
A2Q26	1854-C039		TSTR:SI NPN	28480	1854-C071
A2Q27	1853-C012		TSTR:SI PNP	80131	2N3053
A2R1	0698-4270	12	R:FXD FLM 4.7K OHM 5% 1/8W	28480	2N2904A
A2R2	0683-1025	33	R:FXD CCMP 1000 OHM 5% 1/4W	01121	0698-4270
A2R3	0698-4276	18	R:FXD FLM 10K OHM 5% 1/8W	28480	CB 1025
A2R4	0757-0757	12	R:FXD MET FLM 90.9 OHM 1% 1/2W	28480	0698-4278
A2R5	0698-4270		R:FXD FLM 4.7K OHM 5% 1/8W	28480	0757-0797
A2R6	0683-1025		R:FXD CCMP 1000 OHM 5% 1/4W	01121	0698-4270
A2R7	0698-4276		R:FXD FLM 10K OHM 5% 1/8W	28480	CB 1025
A2R8	0698-4262	7	R:FXD FLM 2.2K OHM 5% 1/8W	28480	0698-4278
A2R9	0757-0757		R:FXD MET FLM 90.9 OHM 1% 1/2W	28480	0698-4262
A2R10	0698-4270		R:FXD FLM 4.7K OHM 5% 1/8W	28480	0757-0797
A2R11	0683-1025		R:FXD CCMP 1000 OHM 5% 1/4W	01121	0698-4270
A2R12	0698-4276		R:FXD FLM 10K OHM 5% 1/8W	28480	CB 1025
A2R13	0757-0757		R:FXD MET FLM 90.9 OHM 1% 1/2W	28480	0698-4278
A2R14	0698-4270		R:FXD FLM 4.7K OHM 5% 1/8W	28480	0757-0797
A2R15	0683-1025		R:FXD CCMP 1000 OHM 5% 1/4W	01121	0698-4270
A2R16	0698-4276		R:FXD FLM 10K OHM 5% 1/8W	28480	CB 1025
A2R17	0757-0757		R:FXD MET FLM 90.9 OHM 1% 1/2W	28480	0698-4278
A2R18	0698-4270		R:FXD FLM 4.7K OHM 5% 1/8W	28480	0757-0797
A2R19	0683-1025		R:FXD CCMP 1000 OHM 5% 1/4W	01121	0698-4270
A2R20	0698-4276		R:FXD FLM 10K OHM 5% 1/8W	28480	CB 1025
A2R21	0757-0757		R:FXD MET FLM 90.9 OHM 1% 1/2W	28480	0698-4278
A2R22	0698-4270		R:FXD FLM 4.7K OHM 5% 1/8W	28480	0757-0797
A2R23	0683-1025		R:FXD CCMP 1000 OHM 5% 1/4W	01121	0698-4270
A2R24	0698-4276		R:FXD FLM 10K OHM 5% 1/8W	28480	CB 1025
A2R25	0757-0757		R:FXD MET FLM 90.9 OHM 1% 1/2W	28480	0698-4278
A2R26	0698-4270		R:FXD FLM 4.7K OHM 5% 1/8W	28480	0757-0797
A2R27	0683-1025		R:FXD CCMP 1000 OHM 5% 1/4W	01121	0698-4270
A2R28	0698-4276		R:FXD FLM 10K OHM 5% 1/8W	28480	CB 1025
A2R29	0757-0757		R:FXD MET FLM 90.9 OHM 1% 1/2W	28480	0698-4278
A2R30	0698-4270		R:FXD FLM 4.7K OHM 5% 1/8W	28480	0757-0797
A2R31	0683-1025		R:FXD CCMP 1000 OHM 5% 1/4W	01121	0698-4270
A2R32	0698-4276		R:FXD FLM 10K OHM 5% 1/8W	28480	CB 1025
A2R33	0757-0757		R:FXD MET FLM 90.9 OHM 1% 1/2W	28480	0698-4278
A2R34	0683-1025		R:FXD CCMP 1000 OHM 5% 1/4W	01121	0757-0797
A2R35	0698-4261	5	R:FXD FLM 2K OHM 5% 1/8W	28480	0698-4261
A2R36	0698-4242	5	R:FXD FLM 300 OHM 5% 1/8W	28480	0698-4242
A2R37	0683-1025		R:FXD CCMP 1000 OHM 5% 1/4W	01121	CB 1025
A2R38	0698-4261		R:FXD FLM 2K OHM 5% 1/8W	28480	0698-4261
A2R39	0698-4242		R:FXD FLM 300 OHM 5% 1/8W	28480	0698-4242
A2R40	0683-1025		R:FXD CCMP 1000 OHM 5% 1/4W	01121	CB 1025
A2R41	0683-1025		R:FXD CCMP 1000 OHM 5% 1/4W	01121	CB 1025
A2R42	0683-1025		R:FXD CCMP 1000 OHM 5% 1/4W	01121	CB 1025
A2R43	0698-4261		R:FXD FLM 2K OHM 5% 1/8W	28480	0698-4261
A2R44	0698-4242		R:FXD FLM 300 OHM 5% 1/8W	28480	0698-4242
A2R45	0683-1025		R:FXD CCMP 1000 OHM 5% 1/4W	01121	CB 1025
A2R46	0698-4261		R:FXD FLM 2K OHM 5% 1/8W	28480	0698-4261
A2R47	0698-4242		R:FXD FLM 300 OHM 5% 1/8W	28480	0698-4242
A2R48	0683-1025		R:FXD CCMP 1000 OHM 5% 1/4W	01121	CB 1025
A2R49	0698-4261		R:FXD FLM 2K OHM 5% 1/8W	28480	0698-4261

See introduction to this section for ordering information

HP 8746b 0.5-12.4 GHz S-parameter test-set

Model 8746B

Replaceable Parts

Table 6-2. Replaceable Parts

Reference Designation	HP Part Number	Qty	Description	Mfr Code	Mfr Part Number
A2R50	0698-4242	2	R:FXD FLM 300 OHM 5% 1/8W	28480	0698-4242
A2R51	0683-1025		R:FXD CGMP 1000 OHM 5% 1/4W	01121	CB 1025
A2R52	0683-1025		R:FXD CGMP 1000 OHM 5% 1/4W	01121	CB 1025
A2R53	0683-1025		R:FXD CGMP 1000 OHM 5% 1/4W	01121	CB 1025
A2R54	0764-0013		R:FXD MET OX 56 OHM 5% 2W	28480	0764-0013
A2R55	0764-0013	2	R:FXD MET OX 56 OHM 5% 2W	28480	0764-0013
A2R56	0683-1025		R:FXD CGMP 1000 OHM 5% 1/4W	01121	CB 1025
A2R57	0698-4278		R:FXD FLM 10K OHM 5% 1/8W	28480	0698-4278
A2R58	0683-1025		R:FXD CGMP 1000 OHM 5% 1/4W	01121	CB 1025
A2R59	0698-4240		R:FXD FLM 240 OHM 5% 1/8W	28480	0698-4240
A2R60	0698-3613	1	R:FXD MET OX 39 OHM 5% 2W	28480	0698-3613
A2R61	0683-1025		R:FXD CGMP 1000 OHM 5% 1/4W	01121	CB 1025
A2R62	0683-1025	1	R:FXD CGMP 1000 OHM 5% 1/4W	01121	CB 1025
A2R63	0698-4271		R:FXD FLM 5.1K OHM 5% 1/8W	28480	0698-4271
A2R64	0683-1025		R:FXD CGMP 1000 OHM 5% 1/4W	01121	CB 1025
A2R65	0683-2425	1	R:FXD CGMP 2400 OHM 5% 1/4W	01121	CB 2425
A2R66	0683-3915		R:FXD CGMP 390 OHM 5% 1/4W	01121	CB 3915
A2R67	0683-1025		R:FXD CGMP 1000 OHM 5% 1/4W	01121	CB 1025
A2R68	0698-4240		R:FXD FLM 240 OHM 5% 1/8W	28480	0698-4240
A2R69	0683-0685		R:FXD CGMP 6.8 OHM 5% 1/4W	01121	CB68G5
A2U1	1820-0092	2	INTEGRATED CIRCUIT: SWITCHING CONVERTER	28480	1820-0092
A2U2	1820-0092		INTEGRATED CIRCUIT: SWITCHING CONVERTER	28480	1820-0092
A3	08746-60051	1	BOARD ASSY: SWITCH DRIVER	28480	08746-60051
A3C1	0160-2530	6	C:FXD CER 0.01 UF +80-20% 100VDCW	91418	TA
A3C2	0160-2530		C:FXD CER 0.01 UF +80-20% 100VDCW	91418	TA
A3C3	0160-2530	5	C:FXD CER 0.01 UF +80-20% 100VDCW	91418	TA
A3C4	0160-2530		C:FXD CER 0.01 UF +80-20% 100VDCW	91418	TA
A3C5	0160-2530		C:FXD CER 0.01 UF +80-20% 100VDCW	91418	TA
A3CR1	1901-0025		DIODE: SILICON 100MA/1V	07263	FD 2387
A3CR2	1902-0041		DIODE: BREAKDOWN 5.11V 5%	04713	SZ10939-98
A3CR3	1901-0025	5	DIODE: SILICON 100MA/1V	07263	FD 2387
A3CR4	1902-0041		DIODE: BREAKDOWN 5.11V 5%	04713	SZ10939-98
A3CR5	1901-0025		DIODE: SILICON 100MA/1V	07263	FD 2387
A3CR6	1902-0041		DIODE: BREAKDOWN 5.11V 5%	04713	SZ10939-98
A3CR7	1901-0025		DIODE: SILICON 100MA/1V	07263	FD 2387
A3CR8	1902-0041		DIODE: BREAKDOWN 5.11V 5%	04713	SZ10939-98
A3CR9	1902-0025		DIODE: BREAKDOWN: 10.0V 5% 400 MH	28480	1902-0025
A3CR10	1901-0025	DIODE: SILICON 100MA/1V	07263	FD 2387	
A3CR11	1901-0025	DIODE: SILICON 100MA/1V	07263	FD 2387	
A3CR12	1901-0025	DIODE: SILICON 100MA/1V	07263	FD 2387	
A3CR13	1901-0025	5	DIODE: SILICON 100MA/1V	07263	FD 2387
A3CR14	1902-3104		DIODE: BREAKDOWN 5.62V 5%	04713	SZ10939-110
A3CR15	1902-3104		DIODE: BREAKDOWN 5.62V 5%	04713	SZ10939-110
A3CR16	1901-0025		DIODE: SILICON 100MA/1V	07263	FD 2387
A3CR17	1901-0025		DIODE: SILICON 100MA/1V	07263	FD 2387
A3CR18	1901-0025		DIODE: SILICON 100MA/1V	07263	FD 2387
A3CR19	1901-0025		DIODE: SILICON 100MA/1V	07263	FD 2387
A3CR20	1902-3104	DIODE: BREAKDOWN 5.62V 5%	04713	SZ10939-110	
A3CR21	1901-0025	DIODE: SILICON 100MA/1V	07263	FD 2387	
A3CR22	1901-0025	DIODE: SILICON 100MA/1V	07263	FD 2387	
A3CR23	1902-3104	5	DIODE: BREAKDOWN 5.62V 5%	04713	SZ10939-110
A3CR24	1902-3104		DIODE: BREAKDOWN 5.62V 5%	04713	SZ10939-110
A3CR25	1901-0025		DIODE: SILICON 100MA/1V	07263	FD 2387
A3CR26	1901-0025		DIODE: SILICON 100MA/1V	07263	FD 2387
A3CR27	1901-0025		DIODE: SILICON 100MA/1V	07263	FD 2387
A3CR28	1901-0025	5	DIODE: SILICON 100MA/1V	07263	FD 2387
A3Q1	1854-0071		TSTR:SI NPN(SELECTED FROM 2N3704)	28480	1854-0071
A3Q2	1853-0020		TSTR:SI PNP(SELECTED FROM 2N3702)	28480	1853-0020
A3Q3	1854-0071		TSTR:SI NPN(SELECTED FROM 2N3704)	28480	1854-0071
A3Q4	1853-0020	TSTR:SI PNP(SELECTED FROM 2N3702)	28480	1853-0020	
A3Q5	1854-0071	5	TSTR:SI NPN(SELECTED FROM 2N3704)	28480	1854-0071
A3Q6	1853-0020		TSTR:SI PNP(SELECTED FROM 2N3702)	28480	1853-0020
A3Q7	1854-0071		TSTR:SI NPN(SELECTED FROM 2N3704)	28480	1854-0071
A3Q8	1853-0020		TSTR:SI PNP(SELECTED FROM 2N3702)	28480	1853-0020
A3Q9	1854-0071		TSTR:SI NPN(SELECTED FROM 2N3704)	28480	1854-0071
A3Q10	1854-0039	5	TSTR:SI NPN	80131	2N3053
A3Q11	1853-0020		TSTR:SI PNP(SELECTED FROM 2N3702)	28480	1853-0020
A3Q12	1854-0071		TSTR:SI NPN(SELECTED FROM 2N3704)	28480	1854-0071
A3Q13	1853-0012		TSTR:SI PNP	80131	2N2904A
A3Q14	1853-0020	TSTR:SI PNP(SELECTED FROM 2N3702)	28480	1853-0020	
A3Q15	1854-0071	5	TSTR:SI NPN(SELECTED FROM 2N3704)	28480	1854-0071
A3Q16	1854-0039		TSTR:SI NPN	80131	2N3053
A3Q17	1853-0020		TSTR:SI PNP(SELECTED FROM 2N3702)	28480	1853-0020
A3Q18	1854-0071		TSTR:SI NPN(SELECTED FROM 2N3704)	28480	1854-0071
A3Q19	1853-0012	TSTR:SI PNP	80131	2N2904A	

See introduction to this section for ordering information

HP 8746b 0.5-12.4 GHz S-parameter test-set

Replaceable Parts

Model 8746B

Table 6-2. Replaceable Parts

Reference Designation	HP Part Number	Qty	Description	Mfr Code	Mfr Part Number
A3Q20	1853-0020		TSTR:SI PNP(SELECTED FROM 2N3702)	28480	1853-0020
A3Q21	1854-0071		TSTR:SI NPN(SELECTED FROM 2N3704)	28480	1854-0071
A3Q22	1854-0035		TSTR:SI NPN	80131	2N3053
A3Q23	1853-0020		TSTR:SI PNP(SELECTED FROM 2N3702)	28480	1853-0020
A3Q24	1854-0071		TSTR:SI NPN(SELECTED FROM 2N3704)	28480	1854-0071
A3Q25	1853-0012		TSTR:SI PNP	80131	2N2904A
A3Q26	1853-0020		TSTR:SI PNP(SELECTED FROM 2N3702)	28480	1853-0020
A3Q27	1854-0071		TSTR:SI NPN(SELECTED FROM 2N3704)	28480	1854-0071
A3Q28	1854-0035		TSTR:SI NPN	80131	2N3053
A3Q29	1853-0020		TSTR:SI PNP(SELECTED FROM 2N3702)	28480	1853-0020
A3Q30	1854-0071		TSTR:SI NPN(SELECTED FROM 2N3704)	28480	1854-0071
A3Q31	1853-0012		TSTR:SI PNP	80131	2N2904A
A3Q32	1853-0020		TSTR:SI PNP(SELECTED FROM 2N3702)	28480	1853-0020
A3Q33	1854-0071		TSTR:SI NPN(SELECTED FROM 2N3704)	28480	1854-0071
A3Q34	1854-0035		TSTR:SI NPN	80131	2N3053
A3Q35	1853-0020		TSTR:SI PNP(SELECTED FROM 2N3702)	28480	1853-0020
A3Q36	1854-0071		TSTR:SI NPN(SELECTED FROM 2N3704)	28480	1854-0071
A3Q37	1853-0012		TSTR:SI PNP	80131	2N2904A
A3Q38	1853-0020		TSTR:SI PNP(SELECTED FROM 2N3702)	28480	1853-0020
A3R1	0698-4270		R:FXD FLM 4.7K OHM 5% 1/8W	28480	0698-4270
A3R2	0683-1025		R:FXD CCMP 1000 OHM 5% 1/4W	01121	CB 1025
A3R3	0698-4278		R:FXD FLM 10K OHM 5% 1/8W	28480	0698-4278
A3R4	0757-0797		R:FXD MET FLM 90.9 OHM 1% 1/2W	28480	0757-0797
A3R5	0698-4270		R:FXD FLM 4.7K OHM 5% 1/8W	28480	0698-4270
A3R6	0683-1025		R:FXD CCMP 1000 OHM 5% 1/4W	01121	CB 1025
A3R7	0698-4278		R:FXD FLM 10K OHM 5% 1/8W	28480	0698-4278
A3R8	0698-4262		R:FXD FLM 2.2K OHM 5% 1/8W	28480	0698-4262
A3R9	0757-0797		R:FXD MET FLM 90.9 OHM 1% 1/2W	28480	0757-0797
A3R10	0698-4270		R:FXD FLM 4.7K OHM 5% 1/8W	28480	0698-4270
A3R11	0683-1025		R:FXD CCMP 1000 OHM 5% 1/4W	01121	CB 1025
A3R12	0698-4278		R:FXD FLM 10K OHM 5% 1/8W	28480	0698-4278
A3R13	0757-0797		R:FXD MET FLM 90.9 OHM 1% 1/2W	28480	0757-0797
A3R14	0698-4270		R:FXD FLM 4.7K OHM 5% 1/8W	28480	0698-4270
A3R15	0683-1025		R:FXD CCMP 1000 OHM 5% 1/4W	01121	CB 1025
A3R16	0698-4278		R:FXD FLM 10K OHM 5% 1/8W	28480	0698-4278
A3R17	0757-0797		R:FXD MET FLM 90.9 OHM 1% 1/2W	28480	0757-0797
A3R18	0683-1025		R:FXD CCMP 1000 OHM 5% 1/4W	01121	CB 1025
A3R19	0683-1025		R:FXD CCMP 1000 OHM 5% 1/4W	01121	CB 1025
A3R20	0698-4278		R:FXD FLM 10K OHM 5% 1/8W	28480	0698-4278
A3R21	0698-4278		R:FXD FLM 10K OHM 5% 1/8W	28480	0698-4278
A3R22	0683-6235	5	R:FXD CCMP 62K OHM 5% 1/4W	01121	CB 6235
A3R23	0683-6235		R:FXD CCMP 62K OHM 5% 1/4W	01121	CB 6235
A3R24	0698-4259	5	R:FXD FLM 1.6K OHM 5% 1/8W	28480	0698-4259
A3R25	0698-4294	5	R:FXD FLM 47K OHM 5% 1/8W	28480	0698-4294
A3R26	0698-4272	5	R:FXD FLM 5.6K OHM 5% 1/8W	28480	0698-4272
A3R27	0698-4262		R:FXD FLM 2.2K OHM 5% 1/8W	28480	0698-4262
A3R28	0698-4259		R:FXD FLM 1.6K OHM 5% 1/8W	28480	0698-4259
A3R29	0698-4294		R:FXD FLM 47K OHM 5% 1/8W	28480	0698-4294
A3R30	0698-4272		R:FXD FLM 5.6K OHM 5% 1/8W	28480	0698-4272
A3R31	0698-4262		R:FXD FLM 2.2K OHM 5% 1/8W	28480	0698-4262
A3R32	0757-0833	10	R:FXD MET FLM 5.11K OHM 1% 1/2W	28480	0757-0833
A3R33	0757-0833		R:FXD MET FLM 5.11K OHM 1% 1/2W	28480	0757-0833
A3R34	0757-0833		R:FXD MET FLM 5.11K OHM 1% 1/2W	28480	0757-0833
A3R35	0757-0833		R:FXD MET FLM 5.11K OHM 1% 1/2W	28480	0757-0833
A3R36	0683-1015	10	R:FXD CCMP 100 OHM 5% 1/4W	01121	CB 1015
A3R37	0683-1015		R:FXD CCMP 100 OHM 5% 1/4W	01121	CB 1015
A3R38	0683-1015		R:FXD CCMP 100 OHM 5% 1/4W	01121	CB 1015
A3R39	0683-1015		R:FXD CCMP 100 OHM 5% 1/4W	01121	CB 1015
A3R40	0683-0335	10	R:FXD CCMP 3.3 OHM 5% 1/4W	01121	CB 0335
A3R41	0683-0335		R:FXD CCMP 3.3 OHM 5% 1/4W	01121	CB 0335
A3R42	0683-0335		R:FXD CCMP 3.3 OHM 5% 1/4W	01121	CB 0335
A3R43	0683-0335		R:FXD CCMP 3.3 OHM 5% 1/4W	01121	CB 0335
A3R44	0683-1025		R:FXD CCMP 1000 OHM 5% 1/4W	01121	CB 1025
A3R45	0698-4278		R:FXD FLM 10K OHM 5% 1/8W	28480	0698-4278
A3R46	0683-6235		R:FXD CCMP 62K OHM 5% 1/4W	01121	CB 6235
A3R47	0698-4259		R:FXD FLM 1.6K OHM 5% 1/8W	28480	0698-4259
A3R48	0698-4294		R:FXD FLM 47K OHM 5% 1/8W	28480	0698-4294
A3R49	0698-4272		R:FXD FLM 5.6K OHM 5% 1/8W	28480	0698-4272
A3R50	0698-4262		R:FXD FLM 2.2K OHM 5% 1/8W	28480	0698-4262
A3R51	0757-0833		R:FXD MET FLM 5.11K OHM 1% 1/2W	28480	0757-0833
A3R52	0757-0833		R:FXD MET FLM 5.11K OHM 1% 1/2W	28480	0757-0833
A3R53	0683-1015		R:FXD CCMP 100 OHM 5% 1/4W	01121	CB 1015
A3R54	0683-1015		R:FXD CCMP 100 OHM 5% 1/4W	01121	CB 1015
A3R55	0683-0335		R:FXD CCMP 3.3 OHM 5% 1/4W	01121	CB 0335
A3R56	0683-0335		R:FXD CCMP 3.3 OHM 5% 1/4W	01121	CB 0335

See introduction to this section for ordering information

HP 8746b 0.5-12.4 GHz S-parameter test-set

Model 8746B

Replaceable Parts

Table 6-2. Replaceable Parts

Reference Designation	HP Part Number	Qty	Description	Mfr Code	Mfr Part Number
A3R57	0683-1025		R:FXD COMP 1000 OHM 5% 1/4W	01121	CB 1025
A3R58	0683-1025		R:FXD COMP 1000 OHM 5% 1/4W	01121	CB 1025
A3R59	0698-4278		R:FXD FLM 10K OHM 5% 1/8W	28480	0698-4278
A3R60	0698-4278		R:FXD FLM 10K OHM 5% 1/8W	28480	0698-4278
A3R61	0683-6235		R:FXD COMP 62K OHM 5% 1/4W	01121	CB 6235
A3R62	0683-6235		R:FXD COMP 62K OHM 5% 1/4W	01121	CB 6235
A3R63	0698-4259		R:FXD FLM 1.6K OHM 5% 1/8W	28480	0698-4259
A3R64	0698-4294		R:FXD FLM 47K OHM 5% 1/8W	28480	0698-4294
A3R65	0698-4272		R:FXD FLM 5.6K OHM 5% 1/8W	28480	0698-4272
A3R66	0698-4262		R:FXD FLM 2.2K OHM 5% 1/8W	28480	0698-4262
A3R67	0698-4259		R:FXD FLM 1.6K OHM 5% 1/8W	28480	0698-4259
A3R68	0698-4294		R:FXD FLM 47K OHM 5% 1/8W	28480	0698-4294
A3R69	0698-4272		R:FXD FLM 5.6K OHM 5% 1/8W	28480	0698-4272
A3R70	0698-4262		R:FXD FLM 2.2K OHM 5% 1/8W	28480	0698-4262
A3R71	0757-0833		R:FXD MET FLM 5.11K OHM 1% 1/2W	28480	0757-0833
A3R72	0757-0833		R:FXD MET FLM 5.11K OHM 1% 1/2W	28480	0757-0833
A3R73	0757-0833		R:FXD MET FLM 5.11K OHM 1% 1/2W	28480	0757-0833
A3R74	0757-0833		R:FXD MET FLM 5.11K OHM 1% 1/2W	28480	0757-0833
A3R75	0683-1015		R:FXD COMP 100 OHM 5% 1/4W	01121	CB 1015
A3R76	0683-1015		R:FXD COMP 100 OHM 5% 1/4W	01121	CB 1015
A3R77	0683-1015		R:FXD COMP 100 OHM 5% 1/4W	01121	CB 1015
A3R78	0683-1015		R:FXD COMP 100 OHM 5% 1/4W	01121	CB 1015
A3R79	0683-0335		R:FXD COMP 3.3 OHM 5% 1/4W	01121	CB 0335
A3R80	0683-0335		R:FXD COMP 3.3 OHM 5% 1/4W	01121	CB 0335
A3R81	0683-0335		R:FXD COMP 3.3 OHM 5% 1/4W	01121	CB 0335
A3R82	0683-0335		R:FXD COMP 3.3 OHM 5% 1/4W	01121	CB 0335
A4	08746-60053	1	BOARD ASSY: SWITCH PANEL	28480	08746-60053
A4DS1	1450-0356	12	LAMP: CLEAR DOME LENS 6.3V	08806	7377
A4DS1	0370-0768	12	LENS: PUSHBUTTON, WHITE	28480	0370-0768
A4DS2	1450-0356		LAMP: CLEAR DOME LENS 6.3V	08806	7377
A4DS2	0370-0768		LENS: PUSHBUTTON, WHITE	28480	0370-0768
A4DS3	1450-0356		LAMP: CLEAR DOME LENS 6.3V	08806	7377
A4DS3	0370-0768		LENS: PUSHBUTTON, WHITE	28480	0370-0768
A4DS4	1450-0356		LAMP: CLEAR DOME LENS 6.3V	08806	7377
A4DS4	0370-0768		LENS: PUSHBUTTON, WHITE	28480	0370-0768
A4DS5	1450-0356		LAMP: CLEAR DOME LENS 6.3V	08806	7377
A4DS5	0370-0768		LENS: PUSHBUTTON, WHITE	28480	0370-0768
A4DS6	1450-0356		LAMP: CLEAR DOME LENS 6.3V	08806	7377
A4DS6	0370-0768		LENS: PUSHBUTTON, WHITE	28480	0370-0768
A4DS7	1450-0356		LAMP: CLEAR DOME LENS 6.3V	08806	7377
A4DS7	0370-0768		LENS: PUSHBUTTON, WHITE	28480	0370-0768
A4DS8	1450-0356		LAMP: CLEAR DOME LENS 6.3V	08806	7377
A4DS8	0370-0768		LENS: PUSHBUTTON, WHITE	28480	0370-0768
A4DS9	1450-0356		LAMP: CLEAR DOME LENS 6.3V	08806	7377
A4DS9	0370-0768		LENS: PUSHBUTTON, WHITE	28480	0370-0768
A4DS10	1450-0356		LAMP: CLEAR DOME LENS 6.3V	08806	7377
A4DS10	0370-0768		LENS: PUSHBUTTON, WHITE	28480	0370-0768
A4DS11	1450-0356		LAMP: CLEAR DOME LENS 6.3V	08806	7377
A4DS11	0370-0768		LENS: PUSHBUTTON, WHITE	28480	0370-0768
A4DS12	1450-0356		LAMP: CLEAR DOME LENS 6.3V	08806	7377
A4DS12	0370-0768		LENS: PUSHBUTTON, WHITE	28480	0370-0768
A4S1	1460-1223	12	SPRING: SWITCH	28480	1460-1223
A4S1	0370-0921	12	PUSHBUTTON: SWITCH, OLIVE BLACK	28480	0370-0921
A4S1	5000-6400	1	LABEL: PUSHBUTTON (S11)	28480	5000-6400
A4S2	1460-1223		SPRING: SWITCH	28480	1460-1223
A4S2	0370-0921	1	PUSHBUTTON: SWITCH, OLIVE BLACK	28480	0370-0921
A4S2	5000-6401		LABEL: PUSHBUTTON (S12)	28480	5000-6401
A4S3	1460-1223		SPRING: SWITCH	28480	1460-1223
A4S3	0370-0921	1	PUSHBUTTON: SWITCH, OLIVE BLACK	28480	0370-0921
A4S3	5000-6402		LABEL: PUSHBUTTON (S21)	28480	5000-6402
A4S4	1460-1223		SPRING: SWITCH	28480	1460-1223
A4S4	0370-0921	1	PUSHBUTTON: SWITCH, OLIVE BLACK	28480	0370-0921
A4S4	5000-6403		LABEL: PUSHBUTTON (S22)	28480	5000-6403
A4S5	1460-1223		SPRING: SWITCH	28480	1460-1223
A4S5	0370-0921	1	PUSHBUTTON: SWITCH, OLIVE BLACK	28480	0370-0921
A4S5	5000-8677	1	LABEL: PUSHBUTTON "0"	28480	5000-8677
A4S6	1460-1223		SPRING: SWITCH	28480	1460-1223
A4S6	0370-0921	1	PUSHBUTTON: SWITCH, OLIVE BLACK	28480	0370-0921
A4S6	5000-8678		LABEL: PUSHBUTTON "10"	28480	5000-8678
A4S7	1460-1223		SPRING: SWITCH	28480	1460-1223
A4S7	0370-0921	1	PUSHBUTTON: SWITCH, OLIVE BLACK	28480	0370-0921
A4S7	5000-8679		LABEL: PUSHBUTTON "20"	28480	5000-8679
A4S8	1460-1223		SPRING: SWITCH	28480	1460-1223
A4S8	0370-0921	1	PUSHBUTTON: SWITCH, OLIVE BLACK	28480	0370-0921
A4S8	5000-8680		LABEL: PUSHBUTTON "30"	28480	5000-8680

See introduction to this section for ordering information

HP 8746b 0.5-12.4 GHz S-parameter test-set

Replaceable Parts

Model 8746B

Table 6-2. Replaceable Parts

Reference Designation	HP Part Number	Qty	Description	Mfr Code	Mfr Part Number
A4S9	1460-1223		SPRING:SWITCH	28480	1460-1223
A4S9	0370-0921		PUSHBUTTON:SWITCH, OLIVE BLACK	28480	0370-0921
A4S9	5000-8681	1	LABEL:PUSHBUTTON "40"	28480	5000-8681
A4S10	1460-1223		SPRING:SWITCH	28480	1460-1223
A4S10	0370-0921		PUSHBUTTON:SWITCH, OLIVE BLACK	28480	0370-0921
A4S10	5000-8682	1	LABEL:PUSHBUTTON "50"	28480	5000-8682
A4S11	1460-1223		SPRING:SWITCH	28480	1460-1223
A4S11	0370-0921		PUSHBUTTON:SWITCH, OLIVE BLACK	28480	0370-0921
A4S11	5000-8683	1	LABEL:PUSHBUTTON "60"	28480	5000-8683
A4S12	1460-1223		SPRING:SWITCH	28480	1460-1223
A4S12	0370-0921		PUSHBUTTON:SWITCH, OLIVE BLACK	28480	0370-0921
A4S12	5000-8684	1	LABEL:PUSHBUTTON "70"	28480	5000-8684

See introduction to this section for ordering information

HP 8746b 0.5-12.4 GHz S-parameter test-set

Model 8746B

Replaceable Parts

Table 6-2. Replaceable Parts

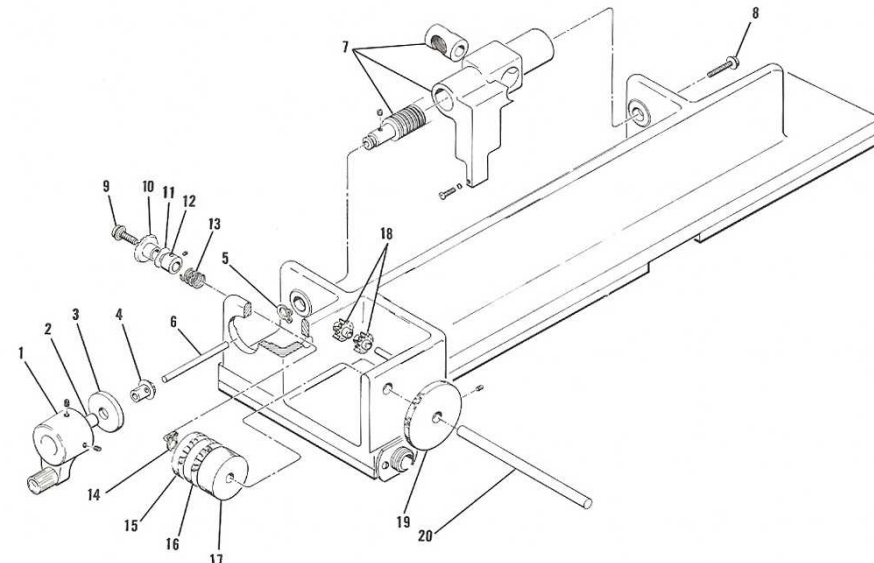
Reference Designation	HP Part Number	Qty	Description	Mfr Code	Mfr Part Number
					
A5	08746-60008	1	LINE STRETCHER ASSY	28480	08746-60008
1	0370-1117	1	KNOB ASSY	28480	0370-1117
2	08740-2052	1	ADAPTER:SHAFT	28480	08740-2092
3	08741-2004	1	BEARING:PINION GEAR	28480	08741-2004
4	08742-2007	1	GEAR:PINION	28480	08742-2007
	3030-0060	1	SCREW:SET 2-56 X 0.062" LG	00000	0BD
5	0510-0005	2	RING:RETAINING	79136	5100-25-S-MD
6	08741-2024	1	DRIVE SHAFT	28480	08741-2024
7	08741-6001	1	LEAD SCREW ASSY	28480	08741-6001
	3030-0022	1	SCREW:SET 6-32 X 0.125" LG	00000	0BD
	08741-2022	1	LEAD SCREW HOUSING & BUSHING	28480	08741-2022
	0520-0003	1	SCREW:SST RH 2-56 X 3/8	28480	0520-0003
	2150-0014	1	WASHER:LOCK FOR #2 HWD	28480	2190-0014
	1410-0165	1	BEARING:BALL FLANGED SINGLE ROW	21335	F4DD FS59069
8	2520-0001	1	SCREW:RND HD SLOT DR 8-32 X 0.250" LG	00000	0BD
9	2360-0004	1	SCREW:RND HD SLOT DR 6-32 X 0.312" LG	00000	0BD
	3050-0100	1	WASHER:FLAT FOR #6 SCREW	00000	0BD
	08740-0005	2	WASHER:SHIM CLUTCH	28480	08740-0005
10	1430-0356	1	GEAR:BEVEL 48 PITCH, 36 TOOTH	71041	6479Y-C
11	5020-0352	2	WASHER:SPRING	28480	5020-0392
12	5020-0233	1	COLLAR	28480	5020-0233
	3030-0001	1	SCREW:MACHINE SET CUP-PT ST 8-32X3/16	70276	0BD#
	6248-59C-5	1	BUSHING	28480	6248-59C-5
13	1460-0019	1	SPRING:COMPRESSION	00000	0BD
14	0510-0053	1	RING:RETAINING FOR 0.188" DIA SHAFT	79136	5555-18-S-MD
15	1140-0008	1	WHEEL:ONE DIGIT	19811	CC-2391-ENRR-WH
16	1140-0007	1	NUMBER WHEEL:COUNTER ROTATING	18911	CC-2391-NRR-WH
17	1140-0009	1	UNIT WHEEL:COUNTER ROTATING	18911	CC-2365-UNRR-G-WH
	1480-0072	1	PIN:ROLL .062 DIA X .375 LG	72962	92-012-062-0375
18	1430-0035	1	GEAR:PINION 22 PITCH 8 TEETH	18911	BB-2219
	08740-2014	1	SHAFT:IDLER	28480	08740-2014
19	08614-295	1	THUMB WHEEL	28480	08614-295
	3030-0033	1	SCREW:SET SST 6-32 X 3/16	28480	3030-0033
20	08742-2008	1	SHAFT:COUNTER	28480	08742-2008
A5R1	08743-60014	2	RESISTOR ASSY:TUNABLE 10DB	28480	08743-60014

See introduction to this section for ordering information

HP 8746b 0.5-12.4 GHz S-parameter test-set

Replaceable Parts

Model 8746B

Table 6-2. Replaceable Parts

Reference Designation	HP Part Number	Qty	Description	Mfr Code	Mfr Part Number
A6	08746-60003	1	STEP ATTENUATOR(NEW)	28480	08746-60003
A6	08746-60010		REBUILT 08746-60003 REQUIRES EXCHANGE	28480	08746-60010
A7	08746-60004	2	SWITCH TREE ASSY	28480	08746-60004
A7S1	08743-60010	2	RELAY ASSY: (PORT 1)	28480	08743-60010
A7S2	08743-60009	2	RELAY ASSY: (CENTER)	28480	08743-60009
A7S3	08743-60011	2	RELAY:ASSY: (PORT 2)	28480	08743-60011
A8	08746-60004		SWITCH TREE ASSY	28480	08746-60004
A8S1	08743-60010		RELAY ASSY: (PORT 1)	28480	08743-60010
A8S2	08743-60009		RELAY ASSY: (CENTER)	28480	08743-60009
A8S3	08743-60011		RELAY:ASSY: (PORT 2)	28480	08743-60011
A9	08746-60009	1	POWER LINE MODULE ASSY	28480	08746-60009
A9	7124-1738	1	LABEL:115 FUSE 1A-230 FUSE 500UA	28480	7124-1738
A9	7124-1739	1	LABEL:115V-230V ±10% 110VA MAX	28480	7124-1739
A9C1 A,B	0160-3043	1	C:FXD CER 2 X 0.005 UF 20% 250VAC	56289	29C147A-CDH
A9C2	0150-0052	1	C:FXD CER 0.05 UF 20% 400VDCW	56289	33C17A
DC1	08746-60001	2	COUPLER ASSY:PORT	28480	08746-60001
DC1			FOR STANDARD MODEL AND .OPTION 001		
DC1	08746-60007	2	COUPLER ASSY:PORT	28480	08746-60007
DC1			FOR OPTIGN 002		
DC1C1	08745-6008	2	C:FXD 1500 PF	28480	08745-6008
DC1C1			NOT FIELD REPLACEABLE		
DC1C2	0180-2210	8	C:FXD ELECT 2 UF +50-10% 150VDCW	28480	0180-2210
DC1C3	0180-2210		C:FXD ELECT 2 UF +50-10% 150VDCW	28480	0180-2210
DC1C4			NOT FIELD REPLACEABLE		
DC1C5			NOT FIELD REPLACEABLE		
DC1C6	0180-2210		C:FXD ELECT 2 UF +50-10% 150VDCW	28480	0180-2210
DC1C7	0180-2210		C:FXD ELECT 2 UF +50-10% 150VDCW	28480	0180-2210
DC1C8			NOT FIELD REPLACEABLE		
DC1C9			NOT FIELD REPLACEABLE		
DC1L1 AND L2		4	NOT FIELD REPLACEABLE		
DC1R1	08743-60014	2	RESISTOR ASSY:TUNABLE 10DB	28480	08743-60014
DC1R1			NOT IN OPTION 002		
DC1R2	0683-1055	4	R:FXD COMP 1 MEGOHM 5% 1/4W	01121	CB 1055
DC1R3	0683-1055		R:FXD COMP 1 MEGOHM 5% 1/4W	01121	CB 1055
DC2	08746-60001		COUPLER ASSY:PORT	28480	08746-60001
DC2			FOR STANDARD MODEL AND OPTION 001		
DC2	08746-60007		COUPLER ASSY:PORT	28480	08746-60007
DC2			FOR OPTION 002		
DC2C1	08745-6008		C:FXD 1500 PF	28480	08745-6008
DC2C2	0180-2210		NOT FIELD REPLACEABLE		
DC2C3	0180-2210		C:FXD ELECT 2 UF +50-10% 150VDCW	28480	0180-2210
DC2C4			C:FXD ELECT 2 UF +50-10% 150VDCW	28480	0180-2210
DC2C5			NOT FIELD REPLACEABLE		
DC2C6	0180-2210		NOT FIELD REPLACEABLE		
DC2C7			C:FXD ELECT 2 UF +50-10% 150VDCW	28480	0180-2210
DC2C8	0180-2210		NOT FIELD REPLACEABLE		
DC2C9			NOT FIELD REPLACEABLE		
DC2L1			NOT FIELD REPLACEABLE		
DC2L2			NOT FIELD REPLACEABLE		
DC2R1	08743-60014		RESISTOR ASSY:TUNABLE 10DB	28480	08743-60014
DC2R1			NOT IN OPTION 002		
DC2R2	0683-1055		R:FXD COMP 1 MEGOHM 5% 1/4W	01121	CB 1055
DC2R3	0683-1055		R:FXD COMP 1 MEGOHM 5% 1/4W	01121	CB 1055
DC3	08746-60002	1	COUPLER ASSY:REFERENCE	28480	08746-60002

See introduction to this section for ordering information

HP 8746b 0.5-12.4 GHz S-parameter test-set

Model 8746B

Replaceable Parts

Table 6-2. Replaceable Parts

Reference Designation	HP Part Number	Qty	Description	Mfr Code	Mfr Part Number
C1			NOT ASSIGNED		
C2			NOT ASSIGNED		
C3	0180-0204	2	C:FWD ELECT 2800 UF +100-10% 40VDCW	56289	D37694 DFP
C4	0180-0204		C:FWD ELECT 2800 UF +100-10% 40VDCW	56289	D37694 DFP
DS1	2140-0244	2	LAMP:GLOW MINIATURE 95V	87034	A1H
F1	2110-0001	1	FUSE:1 AMP (115V LINE)	75915	312001.
F1	2110-0012	5	FUSE:0.5 AMP (230V LINE)	75915	312.500
F2	2110-0012		FUSE:0.5 AMP	75915	312.500
F3	2110-0012		FUSE:0.5 AMP	75915	312.500
F4	2110-0012		FUSE:0.5 AMP	75915	312.500
F5	2110-0012		FUSE:0.5 AMP	75915	312.500
J1	1251-0172	1	CONNECTOR:PRINTED CIRCUIT 22-CONN	28480	1251-0172
J2	1251-0194	1	CONNECTOR:PRINTED CIRCUIT 15-CONTACT	28480	1251-0194
J3	1251-0160	1	CONNECTOR:15 PIN	28480	1251-0160
J4	1251-0233	1	CONNECTOR:PC 44 CONTACTS	28480	1251-0233
J5	1251-0159	1	CONNECTOR:2X15 CONTACT	28480	1251-0159
J6	1251-0085	1	CONNECTOR:FEMALE 36-PIN MINAT	28480	1251-0085
R1	0698-3162	1	R:FWD MET FLM 46.4K OHM 1% 1/8W	28480	0698-3162
S1	3101-1395	1	SWITCH:PUSHBUTTON DPDT (LINE)	76854	53-67280-121/A1H
S1	2140-0244		LAMP:GLOW, NEON	87034	A1H
T1	9100-3136	1	TRANSFORMER:115/230V AC	28480	9100-3136
W1	08746-20014	1	CABLE:COUPLER/REAR PANEL	28480	08746-20014
W2	11604-20021	1	REFERENCE LINE/COAX LINE PATCH CABLE	28480	11604-20021
W3	08746-20015	1	CABLE:REAR PANEL/LINE STRETCHER	28480	08746-20015
W4	08746-20017	1	CABLE:COUPLER/ATTENUATOR	28480	08746-20017
W5A	08746-20018	1	CABLE:ATTENUATOR/SW TREE "A" FOR STANDARD INSTRUMENT	28480	08746-20018
W5A					
W5B	08746-20024	1	CABLE:ATTENUATOR/SW TREE "B" TO SW TREE B(OPT 001 AND OPT 002)	28480	08746-20024
W6	08746-20016	1	CABLE:LINE STRETCHER/REFERENCE	28480	08746-20016
W7	08746-20019	1	CABLE:SW TREE "A"/AUX "DC1"	28480	08746-20019
W8	08746-20021	1	CABLE:MAIN LINE "DC1"/SW TREE B	28480	08746-20021
W9A	08746-20023	1	CABLE:SW TREE "B"/TEST PORT FOR STANDARD INSTRUMENT	28480	08746-20023
W9B	08746-20025	1	CABLE:SW TREE "A"/TEST PORT TO SW TREE A OPT 001 AND OPT 002	28480	08746-20025
W9					
W10	08746-20022	1	CABLE:MAIN LINE "DC2"/SW TREE B	28480	08746-20022
W11	08746-20020	1	CABLE:SW TREE "A"/AUX "DC2"	28480	08746-20020
W12	8120-1348	1	CABLE:POWER	28480	8120-1348
			MISCELLANEOUS		
	0370-0919	4	PUSHBUTTON:END CAP, LH, OLIVE BLACK	28480	0370-0919
	0370-0920	4	PUSHBUTTON:END CAP, RH, OLIVE BLACK	28480	0370-0920
	5000-0051	2	TRIM STRIP	28480	5000-0051
	5000-0736	2	COVER:REAR SIDE 5 X 16	28480	5000-0736
	5000-0737	2	COVER:FRONT SIDE 5 X 16	28480	5000-0737
	5060-0228	1	COVER ASSY:BOTTOM	28480	5060-0228
	5060-0766	2	HANDLE ASSY:RETAINER	28480	5060-0766
	5060-0767	5	FGOT ASSY:FM	28480	5060-0767
	08743-00004	1	COVER ASSY:TGP	28480	08743-00004
	08743-00005	1	COVER:TOP, REAR CORNER	28480	08743-00005
	08746-00005	1	PANEL:REAR	28480	08746-00005
	08746-00006	1	PANEL:FRONT, UPPER	28480	08746-00006
	08746-00007	1	PANEL:FRONT, LOWER	28480	08746-00007
	08746-20008	1	PANEL:FRONT	28480	08746-20008
	08746-20013	2	FRAME:SIDE	28480	08746-20013
	08746-60005	1	WIRING HARNESS:POWER	28480	08746-60005
	08746-60006	1	WIRING HARNESS:LOGIC	28480	08746-60006

See introduction to this section for ordering information

HP 8746b 0.5-12.4 GHz S-parameter test-set

Replaceable Parts

Model 8746B

Table 6-3. Code List of Manufacturers

MFR NO.	MANUFACTURER NAME	ADDRESS	ZIP CODE
00000	U.S.A. COMMON	ANY SUPPLIER OF U.S.A.	
01121	ALLEN BRADLEY CO.	MILWAUKEE, WIS.	53204
04713	MOTOROLA SEMICONDUCTOR PROD. INC.	PHOENIX, ARIZ.	85008
07263	FAIRCHILD CAMERA & INST. CORP. SEMICONDUCTOR DIV.	MOUNTAIN VIEW, CALIF.	94040
08806	G.E. CO. MINIATURE LAMP DEPT.	CLEVELAND, OHIO	44112
19811	DURANT MFG. CO.	MILWAUKEE, WIS.	53201
21335	FAFNIR BEARING CO. THE DIV. TEXTRON INC.	NEW BRITAIN, CONN.	06050
28480	HEWLETT-PACKARD COMPANY	PALO ALTO, CALIF.	94304
56289	SPRAGUE ELECTRIC CO.	N. ADAMS, MASS.	01247
70276	ALLEN MFG. CO.	HARTFORD, CONN.	06101
71041	BOSTON GEAR WORKS DIV N. AMERICAN ROCKWELL CORP.	QUINCY, MASS.	02171
72962	ELASTIC STOP NUT DIV. AMERACE ESNA CORP.	UNION, N.J.	07083
75915	LITTELFUSE INC.	DES PLAINES, ILL.	60016
76854	OAK MFG. CO. DIV. OAK ELECTRO/NETICS CORP.	CRYSTAL LAKE, ILL.	60014
79136	WALDES KOHINOOR INC.	LONG IS. CITY, N.Y.	11101
80131	ELECTRONIC INDUSTRIES ASSOCIATION	WASHINGTON D.C.	20006
87034	MARCO & OAK INDUSTRIES DIV. OAK ELECTRO/NETICS CORP.	ANAHEIM, CALIF.	92803
91418	RADIO MATERIALS CO.	CHICAGO, ILL.	60646

HP 8746b 0.5-12.4 GHz S-parameter test-set

Model 8746B

Replaceable Parts

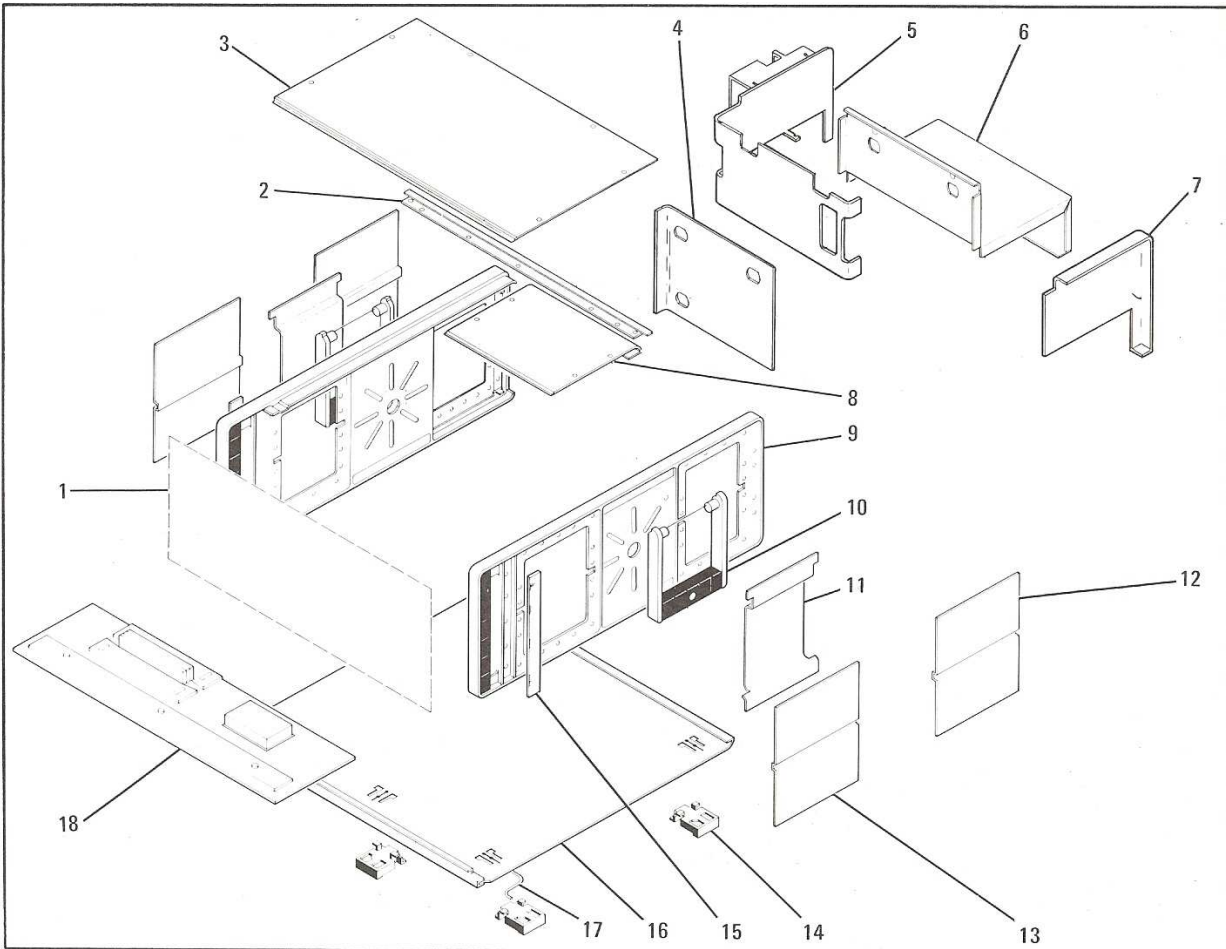

Reference Designation	HP Part Number	Description
1	Refer to Figure 6-2, 8746B Front Panel Assembly	
2	08745-2028	BRACE: TOP
3	08743-00004	COVER ASSY: TOP
4	08746-00005	PANEL: REAR
5	08746-00007	FILLER PIECE: SIDE FRAME
6	08746-00004	SUB DECK
7	08743-00008	FILLER PIECE: SIDE FRAME
8	08743-00005	COVER: TOP REAR CORNER
9	08746-20013	FRAME: SIDE
10	5060-0222	HANDLE ASSEMBLY
11	5060-0766	RETAINER: HANDLE ASSEMBLY
	2550-0016	SCREW: SST BH 8-32 X 5/16"
12	5000-0736	REAR SIDE COVER
	2370-0020	SCREW: SST FH PHL DR 6-32 X 3/16"
13	55000-0737	FRONT SIDE COVER
14	5060-0767	FOOT ASSEMBLY
15	5000-0051	PLATE: FLUTED ALUMINUM
16	5060-0228	BOTTOM COVER ASSEMBLY
17	1490-0030	STAND: TILT
18	5060-0775	KIT: RACK MOUNT

Figure 6-1. Cabinet Parts

HP 8746b 0.5-12.4 GHz S-parameter test-set

Replaceable Parts

Model 8746B

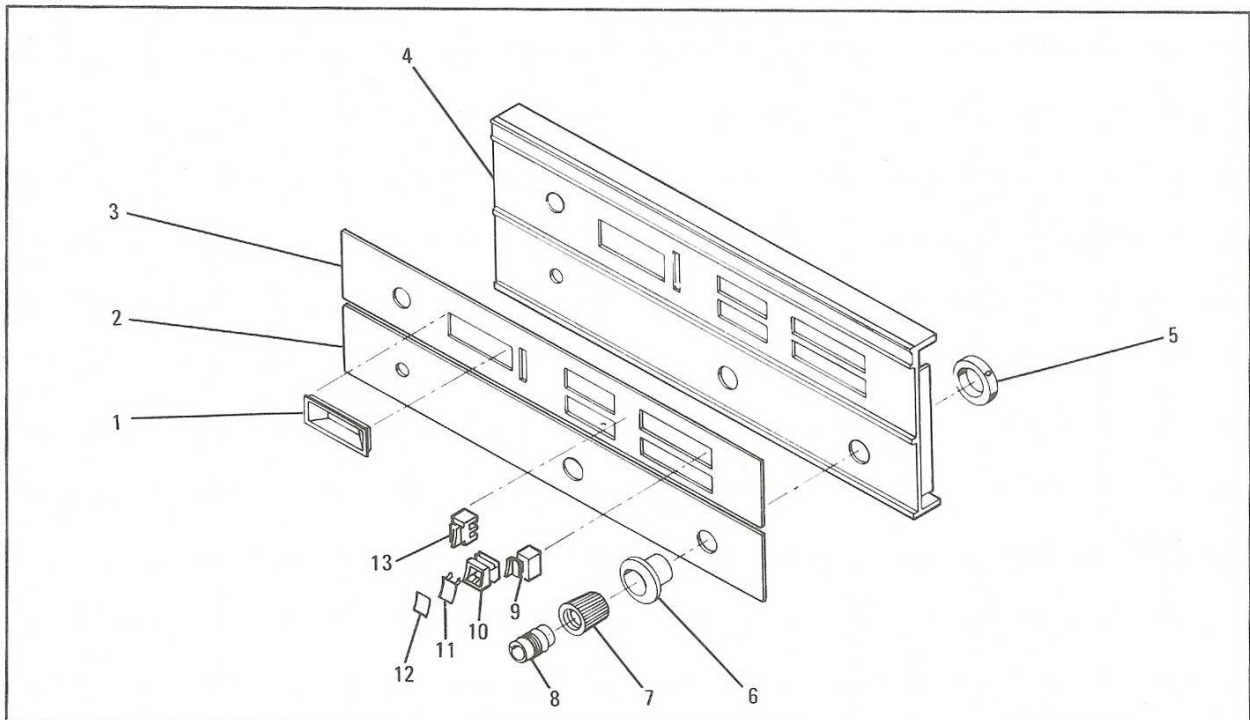

Reference Designator	HP Part Number	Description
1	5040-0328	BEZEL: REFERENCE PLANE EXTENSION
2	08746-00007	PANEL FRONT: LOWER
3	08746-00006	PANEL FRONT: UPPER
4	08745-20008	PANEL FRONT (BACKING PLATE)
5	08742-2036	LOCK RING
6	08746-20006	CONNECTOR MOUNT: SLIDING
7	1250-0819	COUPLING NUT
8	1250-0820	COUPLING SLEEVE ASSEMBLY
9	0370-0920	PUSHBUTTON END CAP: RIGHT (4)
10	0370-0921	PUSHBUTTON: SWITCH (12)
11	0370-0802	LENS: PUSHBUTTON (12)
12	5000-6400	LABEL: PUSHBUTTON ("S ₁₁ ")
	5000-6401	LABEL: PUSHBUTTON ("S ₁₂ ")
	5000-6402	LABEL: PUSHBUTTON ("S ₂₁ ")
	5000-6403	LABEL: PUSHBUTTON ("S ₂₂ ")
	5000-8677	LABEL: PUSHBUTTON ("0")
	5000-8678	LABEL: PUSHBUTTON ("10")
	5000-8679	LABEL: PUSHBUTTON ("20")
	5000-8680	LABEL: PUSHBUTTON ("30")
	5000-8681	LABEL: PUSHBUTTON ("40")
	5000-8682	LABEL: PUSHBUTTON ("50")
	5000-8683	LABEL: PUSHBUTTON ("60")
	5000-8684	LABEL: PUSHBUTTON ("70")
13	0370-0919	PUSHBUTTON END CAP: LEFT (4)

Figure 6-2. Front Panel Assembly

HP 8746b 0.5-12.4 GHz S-parameter test-set

Model 8746B

Replaceable Parts

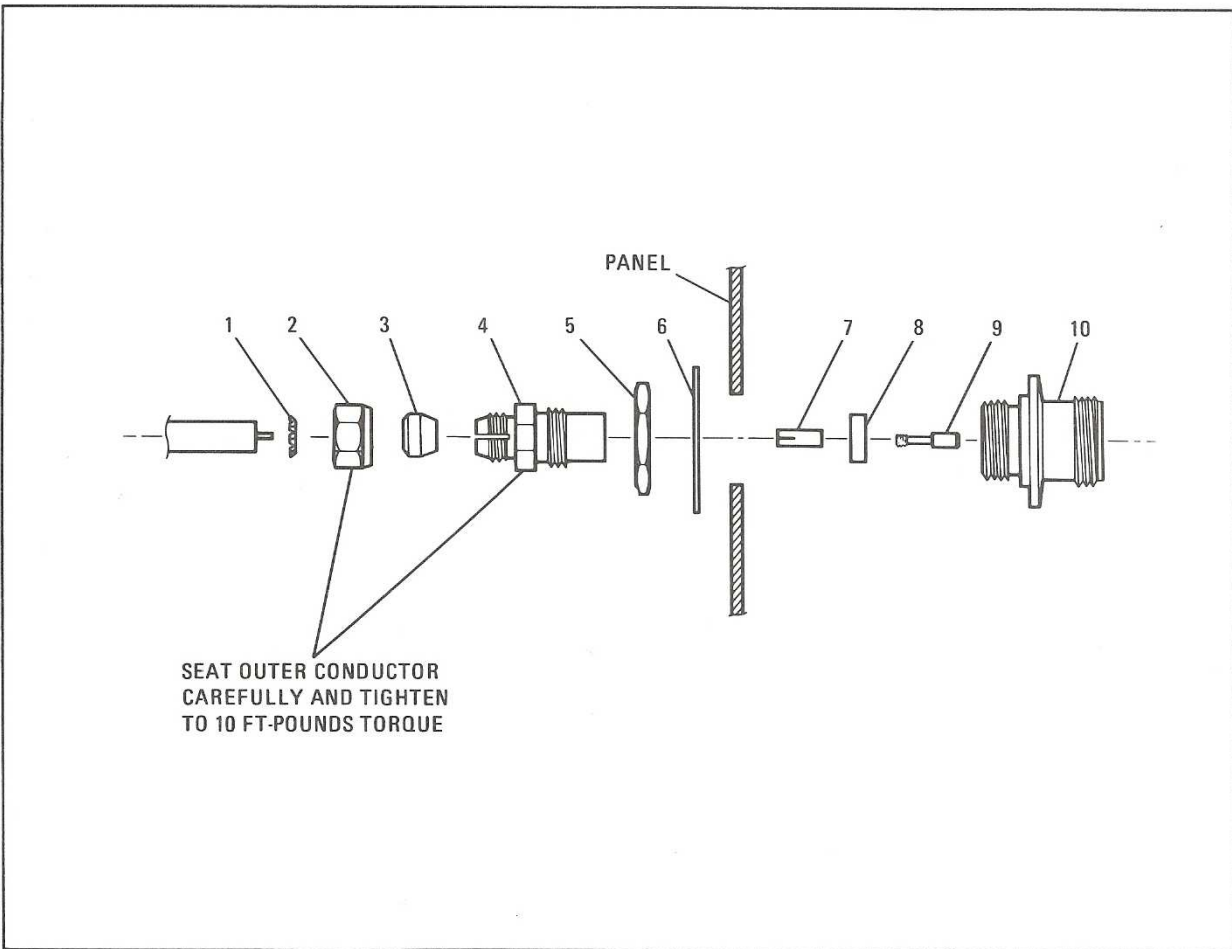

Reference Designator	HP Part Number	Description
1	5000-8676	WASHER
2	5020-7803	NUT: CLAMP
3	5020-7806	FERRULE
4	5020-7805	CABLE: TERMINATOR
5	2950-0079	NUT: HEX 5/8-24 THREAD
6	2190-0493	WASHER: FLAT FOR 5/8" DIA SHAFT
7	08741-2010	CENTER CONDUCTOR: TERMINATOR
8	5040-0306	BEAD
9	1250-0816	HOLDER: CONTACT
10	08745-2047	CONNECTOR BODY: SST

Figure 6-3. REFERENCE & TEST Channel Output and Inboard (W3J1) REFERENCE LINE Connectors

HP 8746b 0.5-12.4 GHz S-parameter test-set

Replaceable Parts

Model 8746B

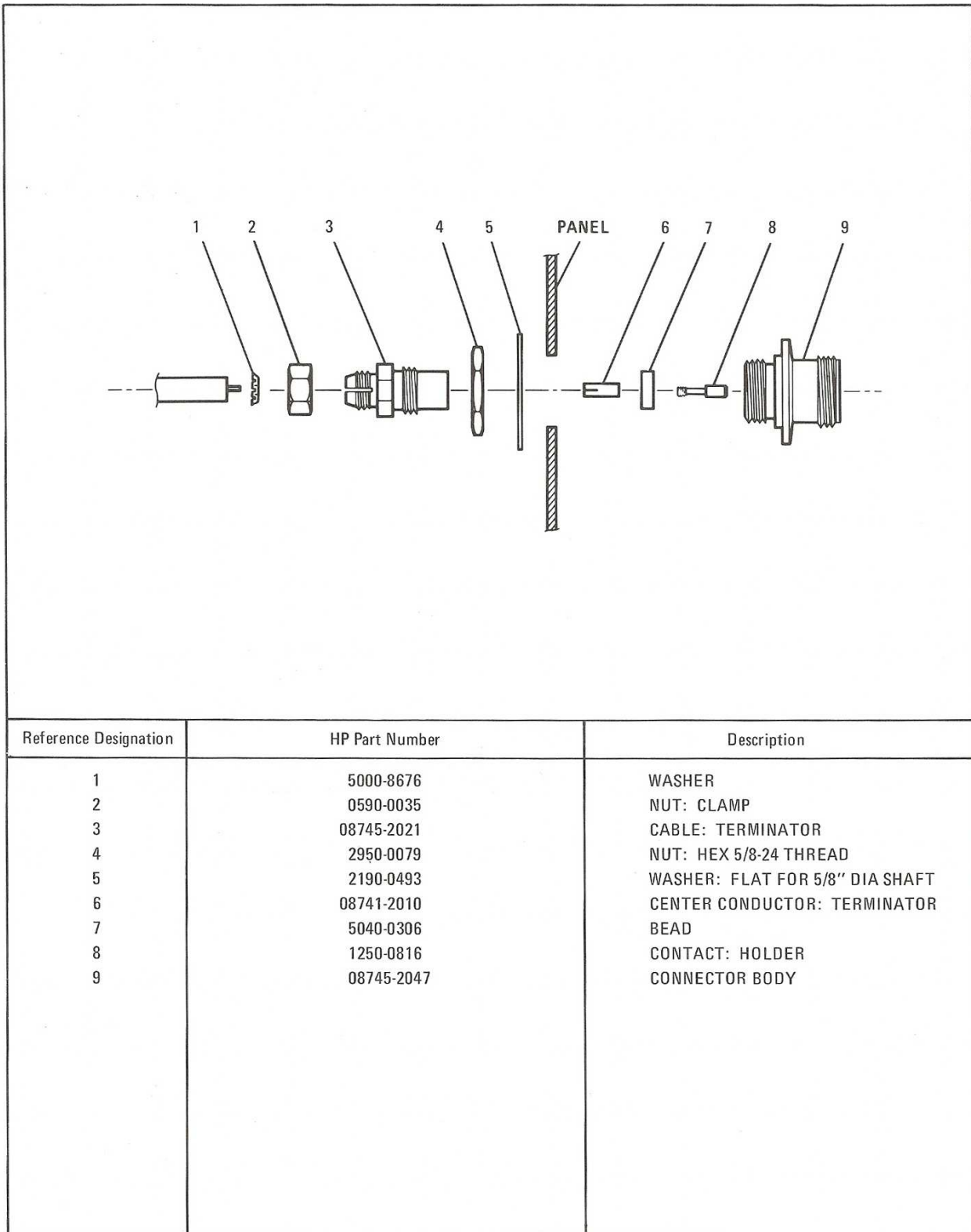

Reference Designation	HP Part Number	Description
1	5000-8676	WASHER
2	0590-0035	NUT: CLAMP
3	08745-2021	CABLE: TERMINATOR
4	2950-0079	NUT: HEX 5/8-24 THREAD
5	2190-0493	WASHER: FLAT FOR 5/8" DIA SHAFT
6	08741-2010	CENTER CONDUCTOR: TERMINATOR
7	5040-0306	BEAD
8	1250-0816	CONTACT: HOLDER
9	08745-2047	CONNECTOR BODY

Figure 6-4. Outboard (W1J1) REFERENCE LINE Connector

HP 8746b 0.5-12.4 GHz S-parameter test-set

Model 8746B

Replaceable Parts

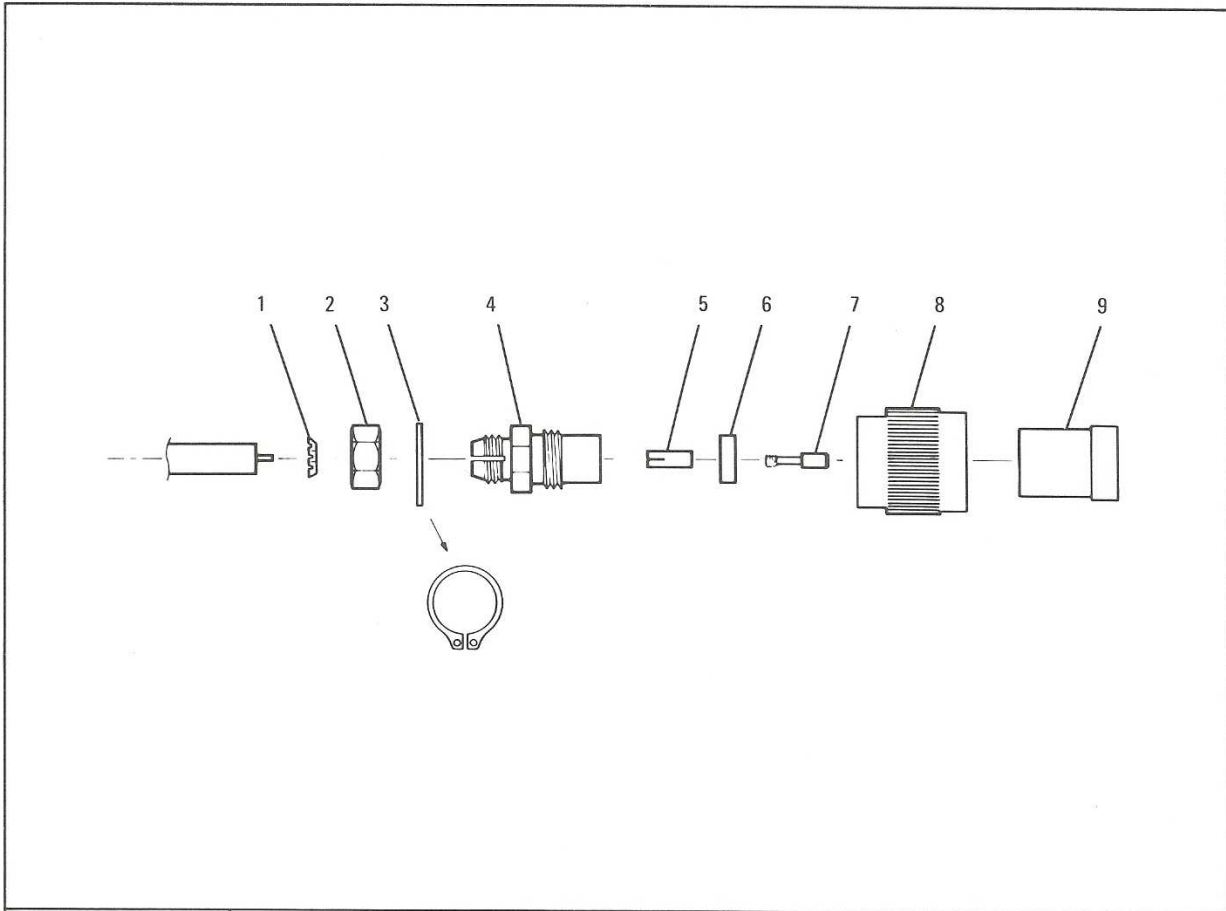

Reference Designation	HP Part Number	Description
1	5000-8676	WASHER
2	0590-0035	NUT: CLAMP
3	0510-0055	RING: TRUARC
4	5020-7805	TERMINATOR: CABLE
	2950-0079	NUT: HEX 5/8-24" THREAD
	2190-0493	WASHER: FLAT FOR 5/8" DIA SHAFT
5	08741-2010	CENTER CONDUCTOR: TERMINATOR
6	5040-0306	BEAD
7	1250-0816	HOLDER: CONTACT
8	11604-20019	COUPLING SHELL: CONNECTOR
9	11604-20020	CONNECTOR BODY: SST

Figure 6-5. REFERENCE LINE Coaxial Cable Connectors (2)

6-17/6-18

SECTION VII
MANUAL CHANGES

7-1. INTRODUCTION

7-2. To adapt this manual to instruments with serial numbers prefixed 983-, make the changes indicated below.

Serial Prefix or Number	Make Manual Changes	Serial Prefix or Number	Make Manual Changes
983-	1		

CHANGE 1

SERVICE NOTE

For serial prefix 983- it is recommended that A2Q22, A2R54, and A2R55 be replaced with the following parts:
 A2Q22: 1854-0062 with heat dissipator 1205-0048.
 A2R54 and A2R55: 0764-0013 R:FXD MET OX 56 OHMS 2W 5%.

The following Manual Changes are to document the parts originally installed in the instrument:

Page 6-4, Table 6-2 Replaceable Parts:
 Change A2Q22 to 1854-0039 TSTR:SI NPN 80131 2N3053 with 1205-0062 HEAT DISSIPATOR.

Page 6-5, Table 6-2 Replaceable Parts:
 Change A2R54 and A2R55 to 0698-3260 R:FXD MET OX 100 OHM 28480 0698-3260.

Page 6-6, Table 6-2 Replaceable Parts:
 Change A3R32, 33, 35, 51 and 52 to 0686-5125 R:FXD DEPC 5100 OHM 5% 1/2W 01121 5125.
 Recommended replacement for these resistors is: 0757-0833 R: FXD MET FLM 5110 OHM 1% 1/2W.

Page 6-7, Table 6-2 Replaceable Parts:
 Change A3R71 and A3R72 to 0686-5125 R:FXD DEPC 5100 OHM 5% 1/2W 01121 5125.
 Recommended replacement for these resistors is: 0757-0833 R:FXD MET FLM 5110 OHM 1% 1/2W.

Page 8-20, Service Sheet 2, A3 Driver Assembly;
 Change A3R32, 33, 34, and 35 to 5100 ohms.

Page 8-24, Service Sheet 4:
 Change A3R51, 52, 71, 72, 73 and 74 to 5100 ohms.

Page 8-28, Service Sheet 6:
 Change A2Q22 to 1854-0039.

**SECTION VIII
SERVICE**

8-1. INTRODUCTION

8-2. This section provides instructions for testing, troubleshooting, and repairing the Model 8746B S-Parameter Test Set.

8-3. PRINCIPLES OF OPERATION

8-4. General principles of operation are described on the first fold-out sheet, opposite the block diagram. This block diagram also serves as an index. Larger numerals on the block diagram refer to Service Sheets as follows:

- Service Sheet 1 consists of RF Circuits
- Service Sheet 2 consists of S-Parameter Latch and Driver Circuits
- Service Sheet 3 consists of Attenuation Latch Circuits
- Service Sheet 4 consists of Attenuator Driver Circuits
- Service Sheet 5 consists of Remote Control Logic Circuits
- Service Sheet 6 consists of Power Supplies (includes Remote Control Power Supply).

8-5. Detailed circuit description for each individual schematic diagram is placed on the facing left-hand foldout page on each Service Sheet. This places all material needed for printed-circuit-level diagnosis in one place, providing easy correlation between function and specific circuitry.

8-6. RECOMMENDED TEST EQUIPMENT

8-7. Test equipment and accessories required to maintain the Model 8746B are listed in Table 1-3. Other equipment may be substituted, provided it meets the specifications listed in the "Critical Specifications" column. Other servicing aids are listed in Table 8-1 Servicing Aids.

8-8. The schematic diagrams in this section represent the circuits electrically. They are not wiring diagrams, though wire colors are given where practical.

8-9. The circuits are arranged according to signal flow; consequently, some switch and circuit assemblies may be shown in part on more than one diagram. If so, the reference designation is preceded by P/O, for "Part Of", and is followed by a notation of the number of parts into which the assembly has been divided.

8-10. Some of the general information obtainable from the schematic diagrams is shown in Table 8-2. Notes and explanations of symbols pertaining to all the diagrams are contained in Table 8-2. Notes about specific components, circuits, or conditions are given on the diagram to which they apply.

8-11. As an aid to finding components and assemblies in the set of diagrams, each diagram has a box labelled Reference Designations that contains all the reference designations appearing on the diagram.

8-12. COMPONENT TROUBLE ISOLATION

8-13. The following information is given to aid in making voltage and resistance measurements.

8-14. Leads of most transistors on the printed circuit boards are in a triangular configuration. The emitter lead is identified by an E alongside the lead on the printed-circuit board. Polarity of diodes is marked on the printed-circuit board by means of the standard schematic symbol. Pin numbers of the

Table 8-1. Servicing Aids

ITEM	HP PART NUMBER
22-pin Extender Board (permits making voltage measurements on board A2)	5060-0630
15-pin Extender Board (permits making voltage measurements on board A1)	5060-0049
Spanner Wrench (permits disassembly of APC-7 type connectors)	5060-0237 (Part of Model 11587A Connector Kit)
Bulb Extractor Tool (permits easy pushbutton lens and pushbutton light bulb replacement)	4040-0427
Service Board (permits remote programming w/clip leads for testing purposes)	08620-60037

microcircuits are shown in an outline drawing on Service Sheet 5. Test points are labelled TP in text, i.e. A1TP1 is test point 1 (1 in a star on schematic) in assembly A1.

8-15. When making voltage measurements, note that they are referenced to a common point, NOT GROUND. This point can be found at any white-black wire, such as on the rear-panel REMOTE/MANUAL switch S2.

8-16. When making ohmmeter measurements on transistors do not use an ohmmeter range that has over 1.5 volts open-circuit voltage on the test leads nor that draws more than 1 milliamperes of short-circuit current.

8-17. ASSEMBLY REPLACEMENT

8-18. Pushbutton Circuit Boards

8-19. To replace a pushbutton board, proceed as follows:

- a. Remove the top cover.
- b. Remove A1, the power supply board, as follows:
 1. Remove the two posi-drive screws holding the power supply's series regulator heat sink (mounting bracket).
 2. Remove the circuit board and heat sink as a unit (unplug from chassis connector).
 3. Remove the electrolytic capacitor mounting bracket by removing the three screws and move the capacitors out of the way.
- c. Remove the eight screws holding the A4 pushbutton circuit board to the pushbuttons.
- d. Remove the pushbutton circuit board A4 from the instrument and disconnect from socket.

To install the Pushbutton Circuit Board:

- a. Install light bulbs into replacement board.
- b. Insert the replacement circuit board into its socket and position circuit board with light bulbs showing through the front panel.
- c. Insert the eight circuit-board mounting screws through the circuit board. Start each screw into the pushbutton end-piece.
- d. Tighten circuit board mounting screws.

e. Install electrolytic capacitor mounting bracket.

f. Install power supply circuit board.

8-20. Switch Tree A

8-21. Switch Tree A consists of three microwave coaxial switches. Each switch may be replaced individually. Refer to the Table of Replaceable Parts in Section VI for part numbers. To replace a switch proceed as follows:

- a. Remove top and bottom covers.
- b. Remove top cross-brace (one screw on each end and one each screw above the TEST and REFERENCE channel connectors).
- c. Disconnect cable W7 (see Schematic 1) at Directional Coupler DC 1 (PORT 1 coupler) by firmly holding the coupler's stainless steel connector with a pair of plastic-jawed pliers, while loosening the 3/4" brass nut.
- d. Disconnect cables W5 and W11 from Switch Tree A, using a 3/4" open-end wrench.
- e. Remove the two socket-head screws holding Switch Tree A to its mounting bracket.
- f. Remove Switch Tree A and cable W7 through the bottom of the instrument.
- g. Disconnect the two white-black wires and one white-green (white-blue on Option 001 or 002) wire from Switch Tree A.
- h. Disconnect cable W7 from Switch Tree A.
- i. Replace defective switch.

To install Switch Tree A:

- a. Insert the replacement switch tree into the instrument from the bottom so that the flat surface of the switches is closest to the front of the instrument and the switch-tree's single port is closest to the left side of the instrument, when viewed from the front.
- b. Make sure coaxial cable center conductor end is concentric. Clean with methanol. Connect cables to switch-tree finger-tight.
- c. Install the two switch-tree mounting screws.
- d. Tighten all cable connections. Firmly hold DC1's stainless-steel connector when tightening W7 at DC1.

e. Solder white-green (white-blue on Options 001 and 002) and two white-black wires to switch-tree terminals with same color wires attached.

f. Install the top cross-brace.

g. Install covers.

8-22. Switch-Tree B

8-23. Switch Tree B consists of three microwave coaxial switches. Each switch may be replaced individually. Refer to the Table of Replaceable Parts in Section VI for part numbers. To replace a switch proceed as follows:

a. Remove top and bottom covers.

b. Remove top cross-brace (one screw on each end and one screw each above the TEST and REFERENCE channel connectors).

c. Disconnect cables W8 (see Schematic 1) and W10 from Switch Tree B (cables W8 and W10 go to DC1 and DC2, respectively).

d. To obtain access to switch tree connectors, disassemble W3J1 (inboard rear-panel REFERENCE LINE connector) as follows:

1. Loosen cable terminator lock-nut using a 1/2" open-end wrench.
2. Partially unscrew cable terminator from connector body using a 7/16" open-end wrench.
3. Remove nut securing connector body to rear panel using 3/4" open-end wrench.
4. Push cable through rear panel and unscrew connector body from terminator.
5. Remove bead assembly, cable terminator, and outer conductor washer from cable.

e. For standard model 8746B, disconnect cable W9 as follows:

1. Disassemble TEST output connector using step d substeps 1 through 4 above.
2. Disconnect W9 from Switch Tree B.

f. For 8746B options 001 and 002, disconnect cable W5 from A6 (step attenuator) and then from Switch Tree B.

g. Loosen the single screw located between the three switches in Switch Tree B. This screw is accessible from the top of the instrument. Push the screw out as far as possible and remove spacer from screw.

h. Remove the allen-screws holding Switch Tree B to its mounting plate.

i. Remove Switch Tree B from the bottom of the instrument.

j. Disconnect the white-black and white-blue (white-green on Options 001 and 002) from the switch tree.

k. Replace the defective switch.

To install Switch Tree B:

a. Install the replacement switch tree so that the flat side of the switches is closest to the right side of the instrument, when viewed from the front, and the single port of the tree is closest to the rear panel.

b. Install spacer and screw located between the switches. Do not tighten screw.

c. Make sure coaxial cable center conductor ends of cables W8 and W10 are concentric. Clean ends with methanol. Connect cables to switch-tree finger-tight.

d. Install and tighten switch-tree mounting screws.

e. Tighten screw located between the switches.

f. Tighten cable W8 and W10 connections.

g. For 8746B standard model connect cable W9 as follows:

1. Make sure coaxial cable center conductor end of cable W9 is concentric. Clean with methanol. Connect finger-tight.
2. Assemble the TEST output connector (see step i substeps 1 through 6).
3. Tighten cable W9 connections.

h. For 8746B option 001 or 002, make sure coaxial cable center conductor end of W5 is concentric. Clean end with methanol. Connect cable W5 to Switch Tree B and then to A6 (attenuator). Tighten connectors.

i. Assemble W3J1 as follows:

1. Install cable terminator and outer conductor washer and nut loosely onto cable. See Figure 6-3 for position of washer.
2. Install bead assembly onto cable terminator.
3. Push cable through rear panel and screw connector body onto cable terminator finger-tight.
4. Tighten nut securing connector to rear panel.
5. Tighten cable terminator in connector body.
6. Tighten terminator lock-nut.

j. Solder the white-black and white-blue (white-green on Options 001 and 002) to Switch Tree B terminals that have corresponding color-coded wires attached.

k. Install top cross-brace.

l. Install covers.

8-24. Step Attenuator (A6) Assembly

8-25. To remove the A6 Step Attenuator Assembly, proceed as follows:

- a. Remove top and bottom covers.
- b. Swing out the circuit-board socket assembly and disconnect cable W4. See page 8-17.
- c. Disconnect cable W4 from the attenuator.
- d. Disconnect cable W5, accessible at the bottom of the instrument, from the attenuator .
- e. Remove the four socket-head screws holding the attenuator to the mounting bracket.
- f. Remove the attenuator through the opening made when the circuit-board connector bracket is swung out.
- g. Mark the color-coded wires to attenuator for identification when installing a replacement attenuator. Disconnect wires. Return attenuator to factory for repair. This attenuator is on an exchange program where it may be exchanged for another attenuator.

To install A6 assembly proceed as follows:

a. Connect color-coded wires to attenuator terminals.

b. Install attenuator through the opening made when circuit-board connector bracket is swung out.

c. Install the four attenuator-mounting screws.

d. Connect cables W4 and W5 to attenuator finger-tight.

e. Tighten attenuator mounting screws.

f. Tighten cables W4 and W5.

g. Install covers.

8-26. Line Stretcher (A5) Assembly

8-27. To remove the A5 Line Stretcher Assembly proceed as follows:

a. Remove the top, bottom, and side panel covers.

b. Remove both front-panel APC-7 connector-coupling assemblies as follows:

1. Partially extend coupling sleeve to serve as a guide for spanner wrench (part of Model 11587A Connector Kit).
2. Position spanner wrench, HP Part No. 5060-0237, so both pegs on the face of the wrench engage holes in the coupling-assembly. Thread spanner wrench coupling nut on connector.
3. Hold gold-plated section of connector firmly with a thin 1/2 inch open-end wrench while removing connector end assembly by unscrewing with the spanner wrench.

CAUTION

Do not allow the gold-plated portion of the connector to rotate while removing the end-assembly. If the connector is allowed to rotate, the directivity of the coupler may be affected.

4. Loosen two allen-screws in lock-ring behind front panel, slide lock-ring back, and remove front-panel connector mount.

- c. Remove the REFERENCE PLANE EXTENSION control knob.
- d. Remove power LINE switch retaining ring.
- e. Remove the fluted-aluminum stick-on trim strip on each side frame, using a razor blade to lift one edge of the strip. On rack-mounted instruments, remove rack-mounting brackets.
- f. Remove the two screws holding the left side-frame to the chassis.
- g. Remove the three screws on each side which hold the side-frame to the front panel.
- h. Remove the top cross-brace by removing one screw at each end of the brace and two screws, one above the TEST and one above the REFERENCE connectors.
- i. Pull the left (when viewed from the front) side-frame out slightly and remove the left end of front panel.
- j. Loosen screws holding right side-frame and remove right end of front panel.
- k. Disconnect the connector to pushbutton circuit-board.
- m. Disconnect Cable W3 from Line Stretcher, using a 3/4 inch open-end wrench.
- n. Disconnect cable W6 at the REFERENCE output connector. Loosen cable terminator lock-nut using 1/2 inch open-end wrench and slide nut back onto cable, then unscrew cable terminator from connector body using 7/16 inch open-end wrench.
- p. Remove three screws on the electrolytic filter-capacitor bracket and swing filter capacitors out of the way.
- q. Remove two screws on power supply mounting bracket and remove power supply assembly.
- r. Remove three screws holding the Line Stretcher's front mounting-plate to the chassis.
- s. Remove two screws holding Line Stretcher to rear panel.
- t. Remove Line Stretcher through the front of the instrument.
- u. Disconnect cable W6 from Line Stretcher's 10 dB attenuator as follows:

- 1. Hold attenuator housing with a 1/2 inch open-end wrench.
- 2. Loosen cable terminator lock-nut using a 1/2 inch open-end wrench, and slide lock-nut back onto cable.
- 3. Unscrew cable terminator from attenuator housing using a 7/16 inch open-end wrench. Bead assembly and washer, HP Part No. 5000-8676, may come loose. Reinsert any loose parts.

To install a Line Stretcher Assembly:

- a. Connect cable W6 to Line Stretcher's 10 dB attenuator. Do not tighten terminator lock-nut. (See Figure 6-3.)
- b. Install Line Stretcher and cable W6 through the front of the instrument.
- c. Make sure coaxial cable center conductor end of cables W3 and W6 are concentric. Clean ends with methanol. Connect finger-tight.
- d. Install three screws holding Line Stretcher's front mounting-plate to the chassis.
- e. Tighten cables W6 and W3.
- f. Install power supply circuit-board and mounting bracket.
- g. Install electrolytic capacitor assembly.
- h. Connect pushbutton circuit-board connector and install front panel.
- i. Install top cross-brace and all side-frame screws.
- j. Install the power LINE switch in front panel.
- k. Turn instrument upside down and install two screws and spacers holding the Line Stretcher to rear panel. To insert spacers, spring rear panel slightly using a screw driver between Line Stretcher and rear panel, if necessary.
- l. Install trim ring and clamp.
- m. Install two APC-7 connector coupling assemblies firmly by holding each outer conductor with an open-end wrench, while tightening the coupling assembly with a spanner wrench.
- n. Install all covers.

8-28. Directional Coupler DC1 (Port 1 Coupler)

8-29. To remove the DC1 Directional Coupler, proceed as follows:

- a. Remove the top and bottom covers.

Note

DC1 is mounted so that the front-panel connector will move slightly to insure mating with the Model 11608A. The position of this Directional Coupler on its mounting plate is critical. Before removing this directional coupler, mark its position (on at least two sides) on the mounting plate to aid in positioning the replacement coupler.

- b. Remove associated APC-7 connector coupling assembly as follows:

1. Partially extend coupling sleeve to serve as a guide for the spanner wrench, HP Part No. 5060-0237 (part of 11587A Connector Kit).
2. Position spanner wrench so both pegs on the front face of the wrench engage holes in the connector face. Tighten wrench sleeve.
3. Hold gold-plated section of connector firmly with a thin 1/2 inch open-end wrench while removing connector coupling-assembly by unscrewing with a spanner wrench.

CAUTION

Do not allow the gold-plated portion of the connector to rotate while removing coupling assembly. If the connector is allowed to rotate, the directivity of the coupler may be affected.

- c. Loosen two allen-screws in lock-ring behind front panel, slide lock-ring back, and remove front-panel connector mount.

- d. Disconnect cable W8 from switch tree B. Cable W8 will be disconnected from the L-shaped adapter later, after the Directional Coupler is removed.

- e. Disconnect cable W7 from DC1 using a 3/4 inch open-end wrench, while firmly holding the Directional Coupler's stainless-steel connector with a pair of plastic-jawed pliers.

- f. Remove the two pozi-drive screws (accessible from the top).

- g. Remove DC1, the mounting plate, and cable W8 from the instrument.

- h. Disconnect W8 from the Directional Coupler's L-shaped adapter by using two 3/4 inch open-end wrenches.

- i. Disconnect the blue bias-circuit leads from the Directional Coupler.

- j. Remove the mounting plate from the Directional Coupler.

To install Direction Coupler DC1 replacement:

- a. Position new coupler on mounting plate, using marks made for original Directional Coupler.

- b. Make sure coaxial cable center conductor end of cable W8 is concentric. Clean end with methanol. Connect cable W8 to coupler L-shaped adapter. Position cable W8 so that it mates with the switch tree B connector. Tighten W8 with a 3/4 inch open-end wrench.

- c. Reassemble connector coupling assembly on coupler.

CAUTION

Hold coupler connector parts from turning with an open-end wrench. Coupler may be damaged if this is not done.

- d. Slide lock ring over front-panel port of new coupler.

- e. Install new coupler and mounting plate. Do not install mounting-plate screws at this time.

- f. Make sure coaxial cable center conductor ends of cables W7 and 8 are concentric. Clean ends with methanol.

- g. Connect cables W7 and 8 to new coupler finger-tight.

- h. Install front-panel connector mount and lock ring. Do not tighten lock-ring allen screws.

- i. Install APC-7 connector coupling assembly by firmly holding outer conductor with 1/2 inch open-end wrench, while tightening coupling assembly with a spanner wrench.

- j. Adjust the position of new coupler to align front-panel connector as follows:

1. Connect a 20 cm air-line to each front-panel APC-7 connector. These air-lines will aid in aligning the front-panel con-

nectors. A slight tilting of the connectors will be more apparent with the air-lines connected.

2. Loosen 7/16 inch nuts on mounting-plate spacers and adjust to align coupler. Tighten nuts. Do not tighten mounting screws excessively or the connector will not have a slight freedom movement and the mounting-plate spacers may be damaged.
3. If the front-panel connector is out of alignment in any direction the coupler must be repositioned on its mounting plate.
4. With a 20 cm air-line on PORT 1 and PORT 2, connector spacing at the end of the air-lines should be approx. 4.810 inches and ends should be at the same height. Remove air-lines. Check couplers for equal extension from front panel.

k. Tighten cable W7, holding the coupler's stainless-steel connector with a pair of plastic-jawed pliers.

l. Tighten cable W8 at switch tree B.

m. Tighten the front-panel connector-mount lock ring.

n. Solder the blue bias-circuit leads to the coupler's terminals, in any order.

o. Replace instrument top and bottom covers.

8-30. Directional Coupler DC2 (Port 2 Coupler)

8-31. To remove the DC2 Directional Coupler, proceed as follows:

- a. Remove the top and bottom covers.
- b. Remove APC-7 connector coupling assembly as follows:
 1. Partially extend coupling sleeve to serve as a guide for the spanner wrench, HP Part No. 5060-0237. This wrench is part of the HP 11587A Connector Kit.
 2. Position spanner wrench so that both pegs on the face of the spanner wrench engage holes in the connector face. Tighten wrench sleeve.
 3. Hold gold-plated section of connector firmly with a thin 1/2 inch open-end

wrench while removing connector coupling-assembly by unscrewing with spanner wrench.

CAUTION

Do not allow gold-plated portion of connector to rotate while removing the coupling assembly. If connector is allowed to rotate, directivity of coupler may be affected.

c. Loosen the two allen-screws in lock ring located behind front panel, slide lock-ring back, and remove the connector mount from front panel.

d. Disconnect W11 from DC2J2 (bottom of instrument) using a 3/4 inch open-end wrench, while holding stainless-steel part of coupler with a pair of plastic-jawed pliers.

e. Disconnect W10 from the coupler's L-shaped adapter using two 3/4 inch wrenches.

f. Disconnect other end of W10 from switch tree A, and remove W10 completely. Removal is necessary to install new coupler.

g. Remove three screws from electrolytic capacitor mounting bracket and swing the capacitor assembly out of the way.

h. Remove the coupler-mounting brackets from the chassis and then from the Directional Coupler.

i. Remove the Directional Coupler.

j. Unsolder the two green bias leads to the Coupler.

To replace the Directional Coupler DC2, proceed as follows:

- a. Remove APC-7 connector coupling assembly as follows:
 1. Partially extend coupling sleeve to serve as a guide for spanner wrench, HP Part No. 5060-0237.
 2. Position spanner wrench so that both pegs on the face of spanner wrench engage holes in the connector face. Tighten wrench sleeve.
 3. Hold gold-plated section of connector firmly with a thin 1/2 inch open-end wrench while removing connector coupling assembly by unscrewing with spanner wrench.

CAUTION

Do not allow gold-plated portion of connector to rotate while removing the coupling assembly. If connector is allowed to rotate, directivity of coupler may be affected.

- b. Install lock ring on PORT 2 port.
- c. Install new coupler through bottom of the instrument.
- d. Install screws in coupler-mounting bracket. Do not tighten screws in the bracket.
- e. Make sure coaxial cable center conductor end of cable W10 is concentric. Clean end with methanol. Connect cable finger-tight to new coupler and switch tree A.
- f. Inspect center conductor of cable W11 and clean with alcohol, if necessary. Connect cable W11 finger-tight to new coupler.
- g. Install new coupler-mounting brackets to chassis. Do not tighten mounting-bracket screws.
- h. Tighten cables W10 and W11.
- i. Install front-panel connector mount. Do not tighten lock-ring allen screws.
- j. Install APC-7 coupling assembly, firmly holding outer conductor with a thin 1/2 inch open-end wrench while tightening coupling assembly with a spanner wrench.
- k. Adjust position of new coupler to align front-panel connector as follows:
 1. Connect a 20 cm air-line to each front-panel APC-7 connector. These air-lines will aid in aligning the front-panel connectors. A slight tilting of the connectors will be more apparent with the air-lines connected.
 2. Adjust position of coupler and tighten mounting-bracket screws.
 3. With a 20 cm air line on PORT 1 and PORT 2, connector spacing at the end of the air-lines should be approx. 4.810 inches and end should be at the same height. Remove air-lines. Check couplers for equal extension from front panel.
- l. Solder wires to the new coupler's bias-circuit terminals. Wires can be soldered in either order.

- m. Install electrolytic-capacitor mounting bracket.

8-32. Directional Coupler DC 3

8-33. To remove Directional Coupler DC3 (Directional Coupler associated with RF INPUT), proceed as follows:

- a. Remove bottom and top, left (when viewed from front) rear cover.
- b. Disconnect cables W1 and W4, while firmly holding the Directional Coupler's stainless-steel connector with a pair of plastic-jawed pliers.
- c. Loosen the two allen-screws in lock ring located behind rear panel and remove the connector mount.
- d. Remove the two coupler-mounting screws (accessible through top of instrument).
- e. Remove the Directional Coupler from instrument.

To install a new Directional Coupler proceed as follows:

- a. Slide lock ring onto new coupler's type N connector.
- b. Install new coupler in the instrument. Make sure coaxial cable center conductor ends of cables W1 and 4 are concentric. Clean ends with methanol. Tighten ends of cables finger-tight.
- c. Install the two coupler-mounting screws. Do not tighten screws.
- d. Install RF input connector-mount and tighten lock ring. Tighten coupler-mounting screws.
- e. Tighten cables W1 and W4, while firmly holding new coupler's stainless-steel connector with a pair of plastic-jawed pliers.
- f. Install top and bottom instrument covers.

8-34. Port Coupler 10 dB Attenuator

8-35. The directional coupler associated with PORT 1 and PORT 2 (DC1 and 2) in the standard model and Option 001 (not Option 002) contains a 10-dB attenuator. If the return-match reflection is greater than specifications and Switch Tree B is OK, the trouble may be in the 10-dB attenuator. Replace the 10-dB attenuator using the following procedure. Attenuator is HP Part No. 08743-60014.

- a. Remove top and bottom instrument covers.
- b. If PORT 1 coupler, remove nearest instrument side frame.
- c. Loosen coupler mounting plate or brackets.
- d. Remove cable end attached to the L-shaped adapter.
- e. Loosen other cable on coupler. If PORT 1 coupler, swing it out.
- f. With 3/4 inch open-end wrench, unscrew brass nut between L-shaped adapter and stainless-steel connector mount on coupler.
- g. With a spanner wrench, HP Part No. 5060-0237, unscrew connector bead holder.
- h. Remove 10 dB attenuator cartridge, noting which end has the mark.

CAUTION

Do not lose or damage the washer (HP Part No. 2190-0831), sliding contact (HP Part No. 5020-3297), or spring (HP Part No. 1460-0977) behind the sliding contact on both sides of the attenuator cartridge. All of these parts are necessary for proper contact.

To replace the 10 dB attenuator cartridge, proceed as follows:

- a. Install a new 10 dB attenuator cartridge (HP Part No. 08743-60014) with a washer (HP Part No. 2190-0831) on each side of the cartridge.

NOTE

The marked end has the lowest reflection and should be inserted with the marked end toward the coupler.

- b. With a spanner wrench (HP Part No. 5060-0237) screw in connector bead holder.
- c. With 3/4 inch open-end wrench, tighten brass nut between L-shaped adapter and stainless-steel connector mount on coupler.
- d. Inspect coupler connector faces and clean with methanol, if necessary.
- e. Make sure coaxial cable center conductor end is concentric. Clean open cable connectors with methanol.
- f. Remount the couplers.

8-10

- g. Reconnect the cables.
- h. Reconnect side frame, if removed, and replace covers.

8-36. Port 1 and Port 2 Connector Coupling Assemblies

8-37. The coupling assembly of the front-panel PORT 1 and PORT 2 APC-7 connectors is replaceable. To replace a coupling assembly proceed as follows:

- a. Partially extend coupling sleeve to serve as a guide for the spanner wrench, HP Part No. 5060-0237 (part of HP 11587A Connector Kit).
- b. Position spanner wrench so both pegs on the front face of the wrench engage holes in the connector face. Tighten wrench sleeve.
- c. Hold gold-plated section of connector firmly with a thin 1/2 inch open-end wrench while removing connector end-assembly by unscrewing with a spanner wrench.

CAUTION

Do not allow the gold-plated portion of the connector to rotate while removing the end-assembly. If the connector is allowed to rotate, the directivity of the coupler may be affected.

- d. Order coupling sleeve assembly HP Part No. 1250-0820 or coupling nut HP Part No. 1250-0819.
- e. Assemble by reversing the disassembly procedure.

8-38. REPAIR

8-39. Replaceable Parts

8-40. Parts shown in Table 6-3 are replaceable. To replace other parts not listed contact your nearest Hewlett-Packard office.

8-41. Location Diagrams

8-42. The location of test points are shown on Service Sheet 6. The locations of individual components mounted on printed circuit boards are shown opposite the related schematic diagram. The part reference designator may be found from the schematic diagram, then located on the parts identification diagram on the same Service Sheet.

8-43. TROUBLESHOOTING

8-44. Introduction

8-45. Some general troubleshooting information is given in paragraphs 8-48 through 8-63. This information may be helpful in analyzing the trouble and therefore by-passing portions of the troubleshooting procedures.

8-46. A preliminary troubleshooting procedure is given in Figure 8-2. This procedure checks the various instrument functions. For a trouble in a particular function this procedure directs the troubleshooter to another troubleshooting procedure to further isolate the trouble.

8-47. The individual troubleshooting procedures need not be performed one after the other, in order. Preliminary troubleshooting should be performed first, unless the troubleshooter has determined by other means that the trouble is associated with a particular instrument function. If the troubleshooter knows in which circuit the trouble occurs, he can go directly to the troubleshooting for that circuit on the Service Sheet for that circuit. Refer to paragraph 8-3 for a listing of the circuits shown on the various Service Sheets.

8-48. Troubleshooting Procedure

8-49. Troubleshooting is generally divided into two maintenance levels in this manual. The first is the circuit level, which isolates a trouble to a circuit. Troubleshooting flow diagrams provide a simple step-by-step procedure to identify the defective circuit. The second maintenance level isolates the trouble to the component level. A detailed circuit description, a schematic diagram, and a voltage table are provided on each Service Sheet to aid in troubleshooting down to the component level.

8-50. Troubleshooting from Front-Panel Indications

8-51. Many troubles, such as pushbutton lamp circuits, can be narrowed to one particular circuit from the front-panel indications. In these cases, go directly to the troubleshooting flow diagram on the Service Sheet of the circuit involved.

8-52. Troubleshooting from the Display Indicator

8-53. The network analyzer display indicator will also indicate troubles, but the causes may not be readily apparent. Except for total failure, the usual indication is a change in gain. This may be observed on the display indicator or as a change in the 8410A Network Analyzer TEST CHANNEL

GAIN setting required for normal calibration. Normal TEST CHANNEL GAIN for calibration is about 19-22 dB with equal amplitude signals into the test and reference channels and depending upon the particular network analyzer.

8-54. Test Channel Gain Higher Than Normal.

Higher than normal test channel gain for calibration indicates a loss in gain in the test channel. Lower than normal test channel gain for calibration indicates a loss in the reference channel. Discontinuities in the reference channel can often be determined by moving the REFERENCE PLANE EXTENSION and observing the display trace. If the display varies cyclically, the discontinuity is probably in the reference channel.

8-55. Test Channel Gain Lower Than Normal. If

the 8410A Network Analyzer TEST CHANNEL GAIN setting required for calibration is other than normal, the trouble may be of several types. Troubles may be large insertion loss (>5 dB), small insertion loss (<5 dB), and discontinuities. A large insertion loss may cause the system to be unusable. A small insertion loss may be general or occur only at certain frequencies (a tracking problem). These troubles can be narrowed to a particular circuit by referring to the Preliminary Troubleshooting Figure 8-2.

8-56. Isolation of RF Troubles. The paths of the

RF signal change when the s-parameter being measured is changed. This allows logical troubleshooting by observing in which s-parameter positions the trouble occurs and in which positions it is absent. The trouble is in that portion of the RF path common to two or more paths in which the trouble occurs. However, this common path may still contain several coaxial cables, several coaxial switches, and a directional coupler.

8-57. If the trouble is lack of repeatability (non-repeatability of indications upon returning to the same switch position), suspect coaxial switches or switch connectors. If the trouble is catastrophic (no signal through the path), use an ohmmeter to measure for short or open circuits. If some signal is flowing through the path, try moving each coaxial cable gently back-and-forth while observing the display indicator. If the display trace moves, try to narrow the trouble to one connector. If a coaxial connector is at fault, remove connector, disassemble, and check for:

1. Center conductor concentric and in good condition.

2. Outer conductor cable ferrule tight, making good contact with cable, and in proper position.
3. Mating surfaces of cable connector clean and not tilted.
4. Presence and condition of washer between cable and cable terminator.
5. Condition of fingers or female center conductor contact. Repair or replace faulty part, reassemble and retest.

8-58. If the trouble does not appear to be a cable, observe if any of the other components or connectors move while moving the cables. Tighten any loose connectors.

8-59. If neither bad coaxial cables or loose connectors are discovered, suspect the coaxial switches. Test for repeatability by switching s-parameters while observing the display indicator. For a given parameter, the display should repeat each time within .05 dB. Greater change than .05 dB may indicate a bad coaxial switch or that a connector on the switch is moving with switching action.

8-60. A signal source may be connected to a switch tree input with a power meter at the output of the switch to observe the transmission through the switch tree. The loss through the switch tree should be less than 1.5 dB. If the loss is greater, disconnect the individual coaxial switches and measure each individually. Each individual switch should have a loss of less than 0.75 dB. In addition, the loss should be a smooth change with frequency, changing less than 0.5 dB from 8.2 to 12.4 GHz.

8-61. If neither cables, connectors, nor switches appear bad, suspect the coupler in the trouble common path. Do not take the coupler apart. Perform the coupler directivity test in Figure 4-1. If directivity is out of specifications, return coupler or instrument to Hewlett-Packard for repair.

8-62. The coupler may also be removed and tested separately. Connect a signal source to the mainline

port nearest the auxiliary port and a power meter to the other mainline port. Be sure to terminate the auxiliary port with a 50-ohm load so reflections from the open end do not interfere with the measurement. Loss on mainline path of the coupler should be less than 2 dB on the Option 002 and less than 12 dB on the standard model and Option 001. If mainline transmission appears correct, test the auxiliary arm coupling. Remove the power meter from the mainline port and connect the power meter to the auxiliary arm. Connect a 50-ohm load to the mainline port. Coupling should be 20 ± 2 dB down from the signal in the mainline, except at lower frequencies (coupling typically 24 dB down at 500 MHz).

8-63. Other methods of testing RF troubles are possible. If the proper cables and connectors are available, a power meter may be connected to the end of the trouble path which is common to two or more s-parameter paths and transmission can be measured. Determine the proper transmission by adding up the attenuation shown in the path on RF schematic on Service Sheet 1. Determine the defective component by removing a component and repeating the test. A high frequency Time Domain Reflectometer may also be useful in isolating RF troubles.

8-64. SCHEMATIC DIAGRAM NOTES

8-65. Schematic Symbols

8-66. Schematic symbols used on the schematic diagrams are shown in Table 8-2.

8-67. Selected/Non-Selected Terminology

8-68. Both the s-parameter pushbuttons and the incident attenuation pushbuttons operate through a diode matrix. This diode matrix selects various combinations of drivers which operate coaxial relays in both switch trees and the attenuator. A HIGH/LOW terminology has been used on the schematics in this manual. HIGH and LOW refer to voltages only and they do not have any fixed relationship to TRUE/FALSE or operate/non-operate. To find the proper condition of a particular circuit for any pushbutton position, consult the truth table of the Service Sheet of the particular circuit concerned.

HP 8746b 0.5-12.4 GHz S-parameter test-set

Model 8746B

Service

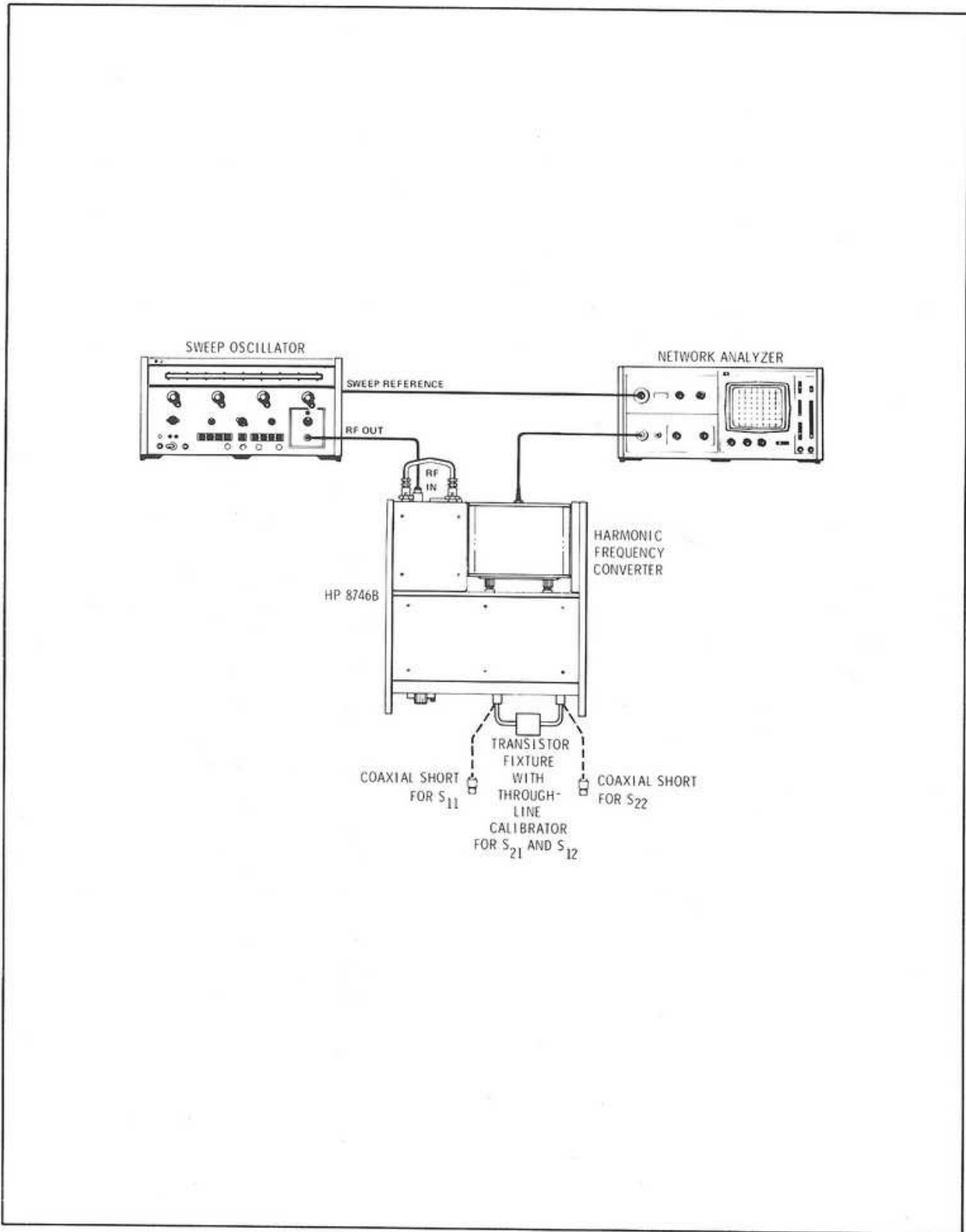

Figure 8-1. Troubleshooting Test Setup

8-13

HP 8746b 0.5-12.4 GHz S-parameter test-set

Service

Model 8746B

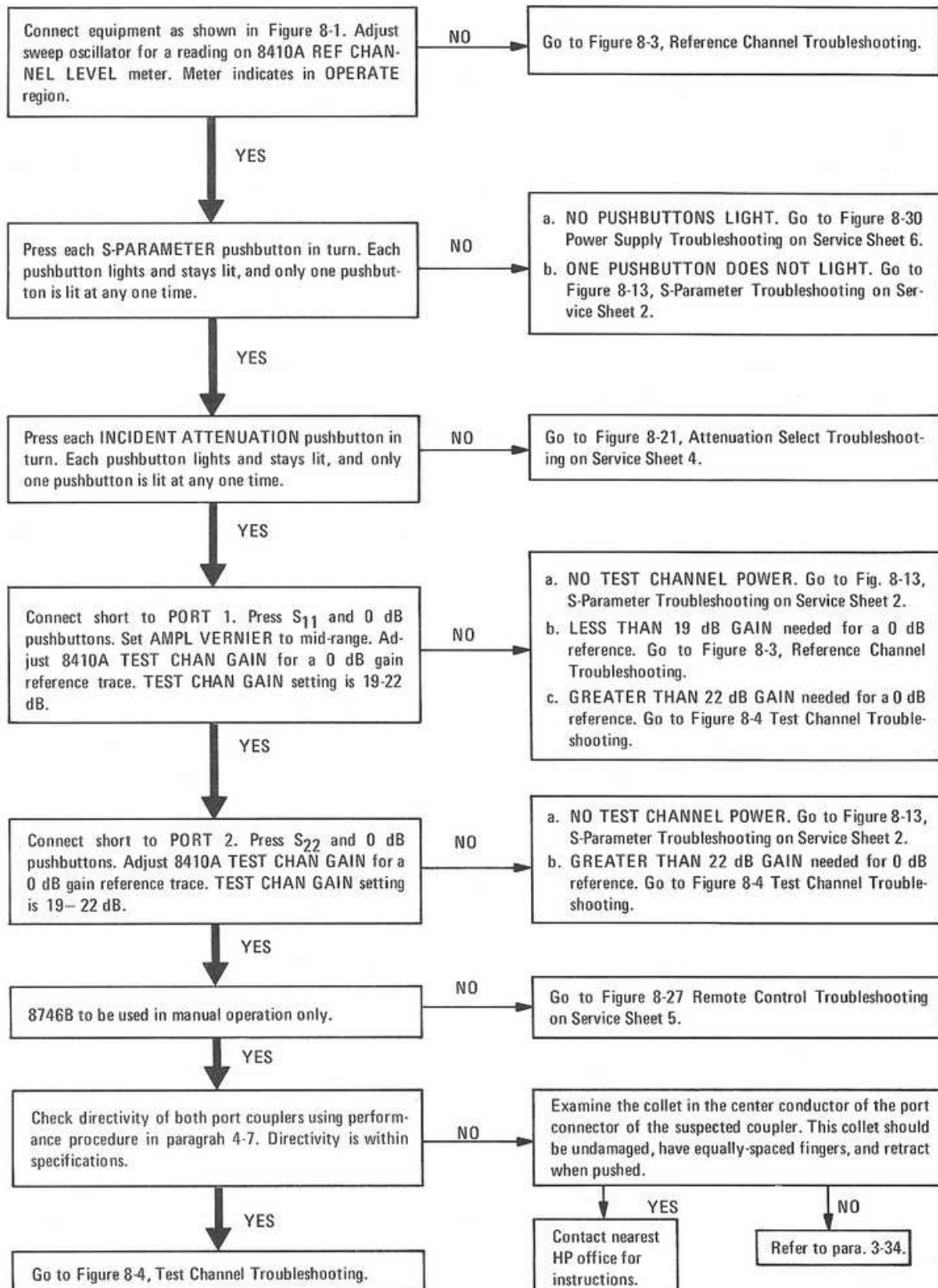
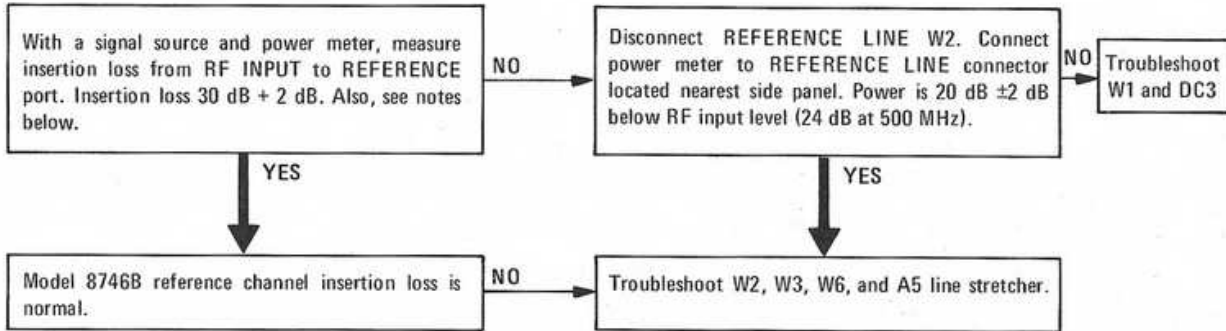

Figure 8-2. Preliminary Troubleshooting

From Preliminary Troubleshooting, Figure 8-2.



Note 1. Reflections from a discontinuity on one side of the line stretcher will combine with reflections in the line stretcher or with reflections from the other side of the line stretcher. The response curve is the resultant of all discontinuities. By changing the line stretcher position, the phase relationship between the sets of reflections changes and the response curve will be altered. Monitor frequency response at several REFERENCE PLANE EXTENSION settings. If the overall power variation is greater than 2 dB at any REFERENCE PLANE EXTENSION setting, the trouble may be in the line stretcher or discontinuities on each side of the line stretcher.

Note 2. A relative increase in power indicates a trouble in the reference channel. A relative decrease in power indicates a trouble in the test channel. A narrow spike is most likely caused by poor contact of cable center conductor pins, one finger of a female pin not making contact, or gross outer conductor separation. A power change over a broader frequency range is most likely caused by a cable outer conductor grounding problem.

Figure 8-3. Reference Channel Troubleshooting

From Preliminary Troubleshooting, Figure 8-2.

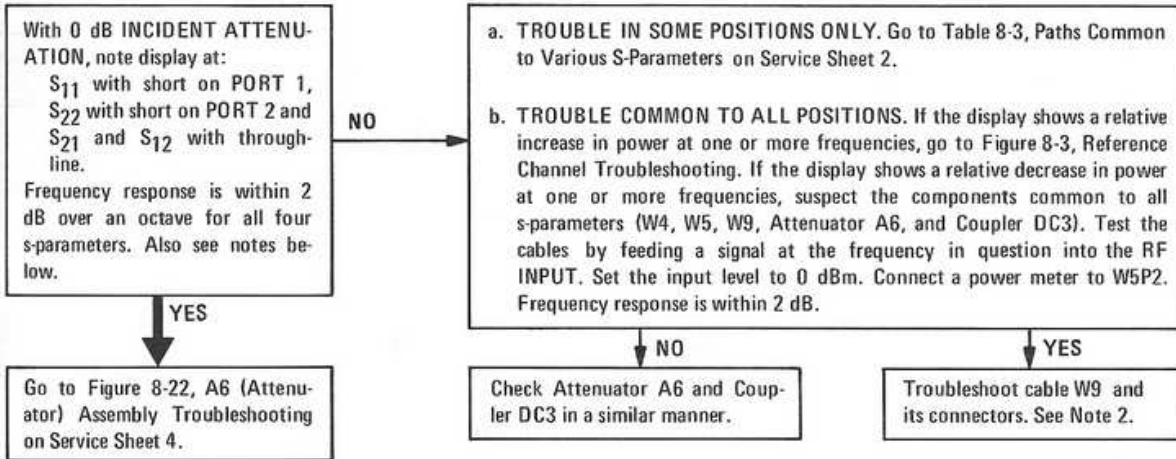

Note 1. Notches of approximately 1 dB in the displayed trace at about 700 MHz are normal. They are caused by resonances in the bias coils in the couplers. See typical trace below.

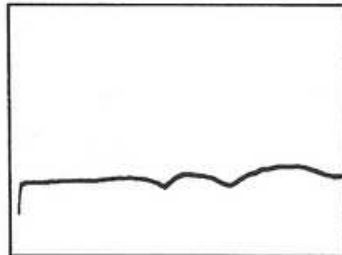

2. A relative increase in power indicates a trouble in the reference channel. A relative decrease in power indicates a trouble in the test channel. A narrow spike is most likely caused by poor contact of cable center conductor pins, one finger of a female pin not making contact, or gross outer conductor separation. A power change over a broader frequency range is most likely caused by a cable outer conductor grounding problem.
3. If a cable's center conductor is not centered it may distort a switch's center conductor contact and cause an increase in insertion loss. The increased insertion loss is most likely to occur from 11 to 12.4 GHz. (See Response Curve.)

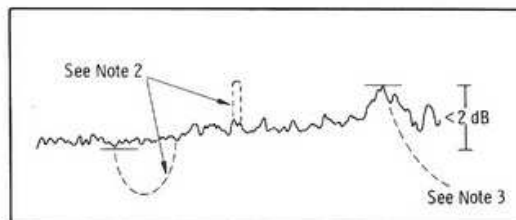

4. See paragraph 8-35 to replace 10 dB attenuator cartridges.

Figure 8-4. Test Channel Troubleshooting

HP 8746b 0.5-12.4 GHz S-parameter test-set

Model 8746B

INDEX BLOCK DIAGRAM AND INTERCONNECT DIAGRAM

Figure 8-7 is the Index Block Diagram and Interconnect Diagram. This diagram shows the signal circuits in block form and their interconnections. Refer to this diagram for an overall picture of operation, signal circuit interconnection details, and as an index for the schematics. To use as an index, first find the block of the circuit of interest. The numeral just inside the lower right corner indicates the Service Sheet (schematic and associated information) on which the circuit will be found.

BLOCK DIAGRAM CIRCUIT DESCRIPTION

The Model 8746B consists of coaxial RF circuitry which can be switched to test the four s-parameters of an unknown. Depending upon which pushbuttons are depressed (or contact closures closed in remote operation), the latch circuits and diode matrices feed corresponding signals to the switch-tree drivers and attenuator drivers. Operation of the switch-tree drivers and attenuator drivers actuates the RF circuitry shown on Service Sheet 1.

The RF switch control circuits consist of pushbutton switches, latch circuits and switch drivers. The pushbuttons on the Switch Panel Assembly A4 actuate latch circuits. When a latch circuit is latched, it provides the correct input signal to a diode matrix. The diode matrix is arranged so that an output from a given latch circuit will be fed to the appropriate driver(s).

The drivers are two-state circuits, i.e., the driver output voltage is either +25V or -25V. A high input from the diode matrix causes a High (+25V) output. A positive driver output causes the associated RF switch(es) s-parameter or attenuator, to switch to one side. A negative driver output (no input to driver) will cause the associated RF switch(s) to switch to the opposite side.

The proper inputs to the Remote Control Circuitry will cause the associated latch circuit to latch. The circuit operation of the remaining circuitry is the same for manual operation as for remote operation. In addition, when using remote closure the INCIDENT ATTENUATION latch circuits may be operated only manually when the MANUAL/REMOTE switch S2 is in MANUAL. When this switch is in the REMOTE position, the INCIDENT ATTENUATION pushbuttons are disabled and attenuation can be selected only by remote closure. For further information concerning remote operation, refer to Service Sheet 5.

INDEX BLOCK
DIAGRAM AND
INTERCONNECT
DIAGRAM

HP 8746b 0.5-12.4 GHz S-parameter test-set

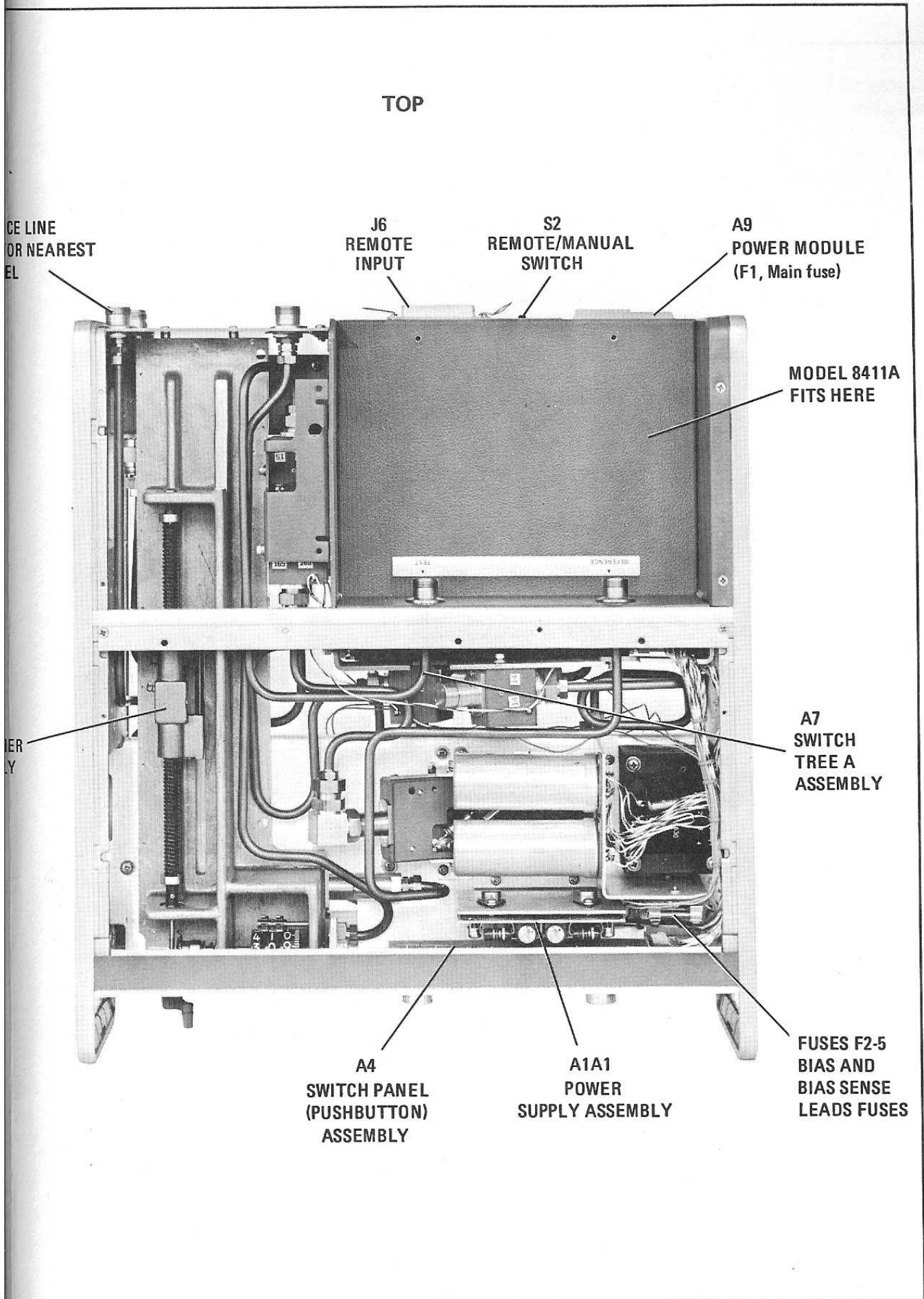

Figure 8-5. Assemblies, Top View

HP 8746b 0.5-12.4 GHz S-parameter test-set

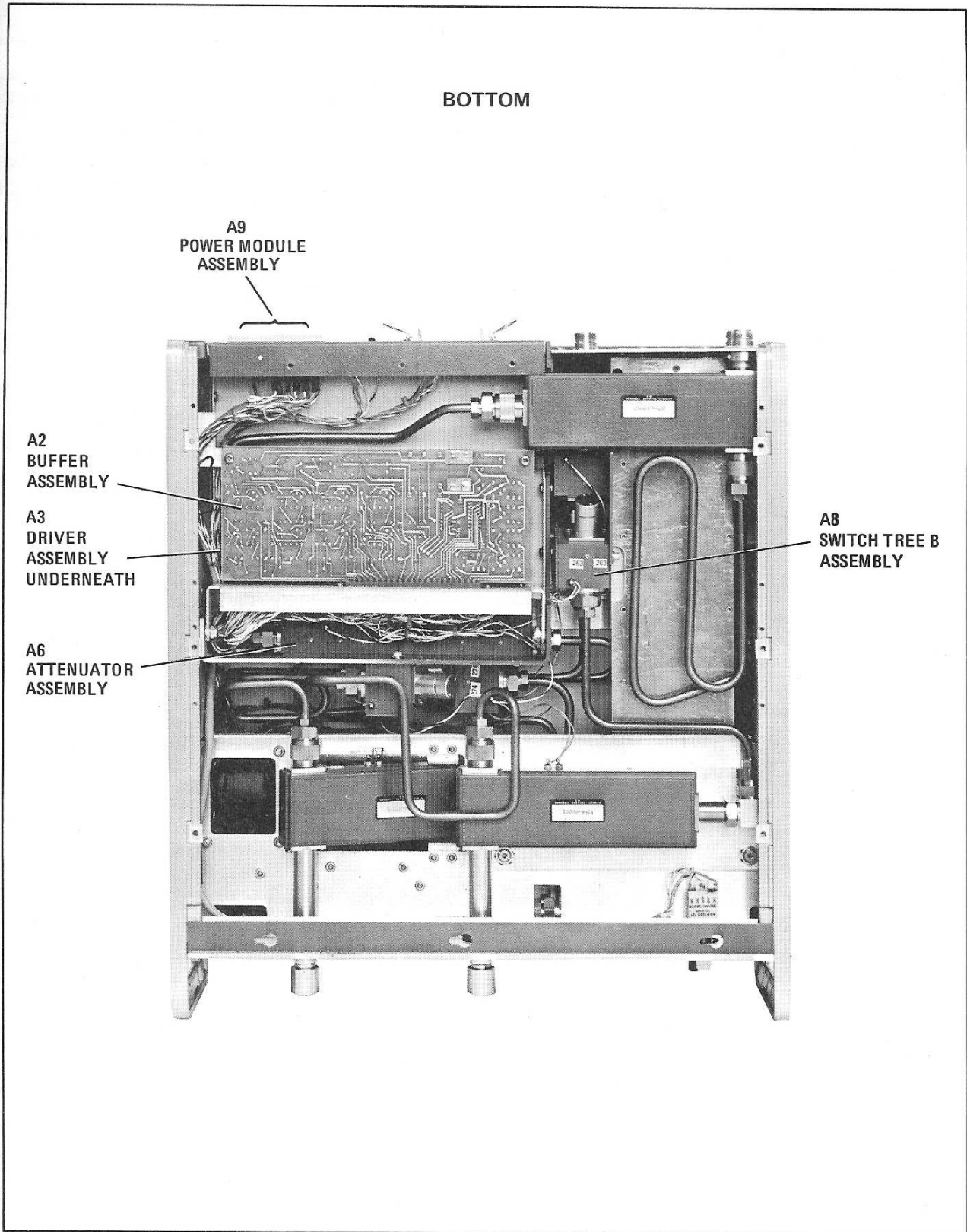

Figure 8-6. Assemblies, Bottom View

HP 8746b 0.5-12.4 GHz S-parameter test-set

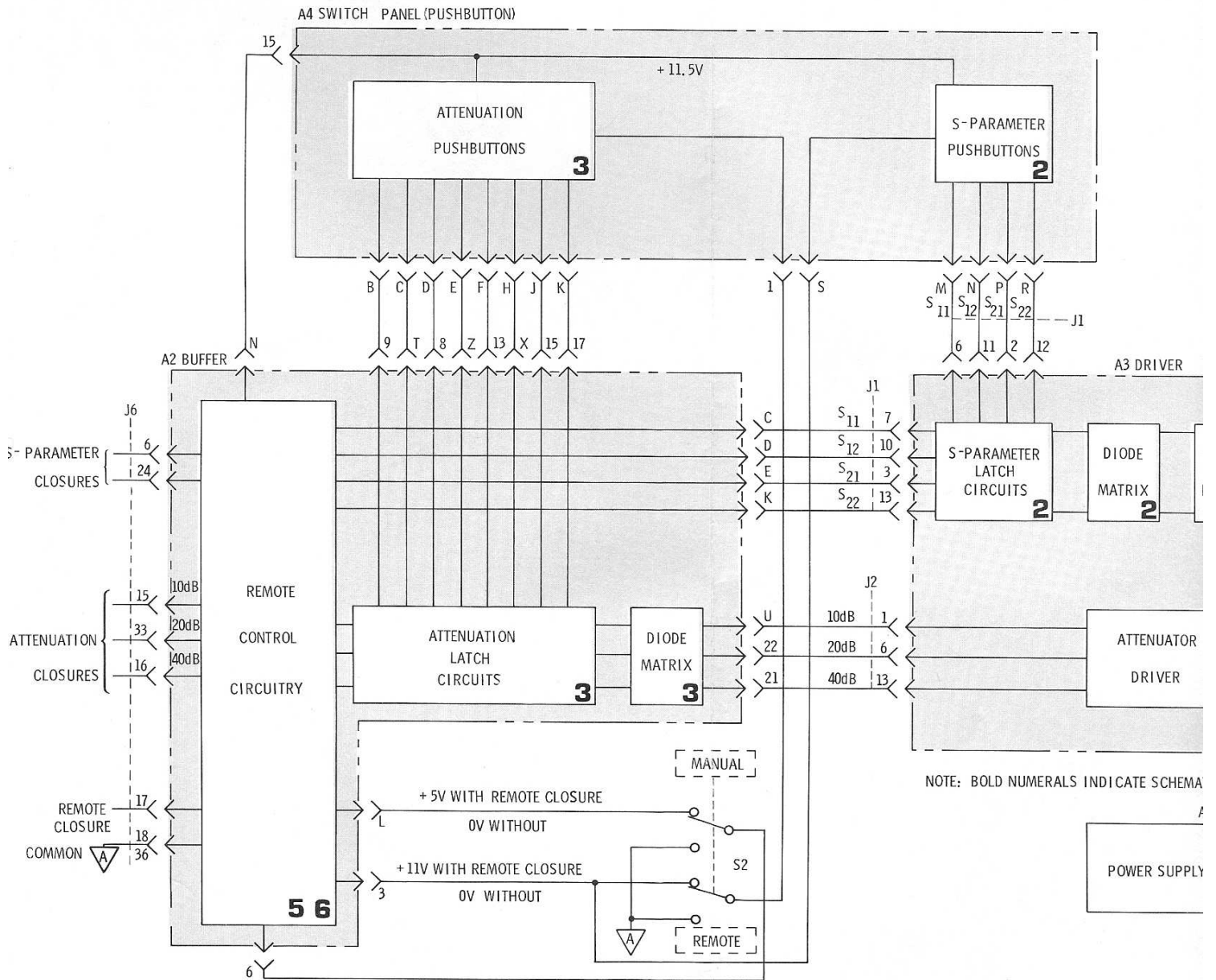

Figure 8-7. Index Block

HP 8746b 0.5-12.4 GHz S-parameter test-set

Service

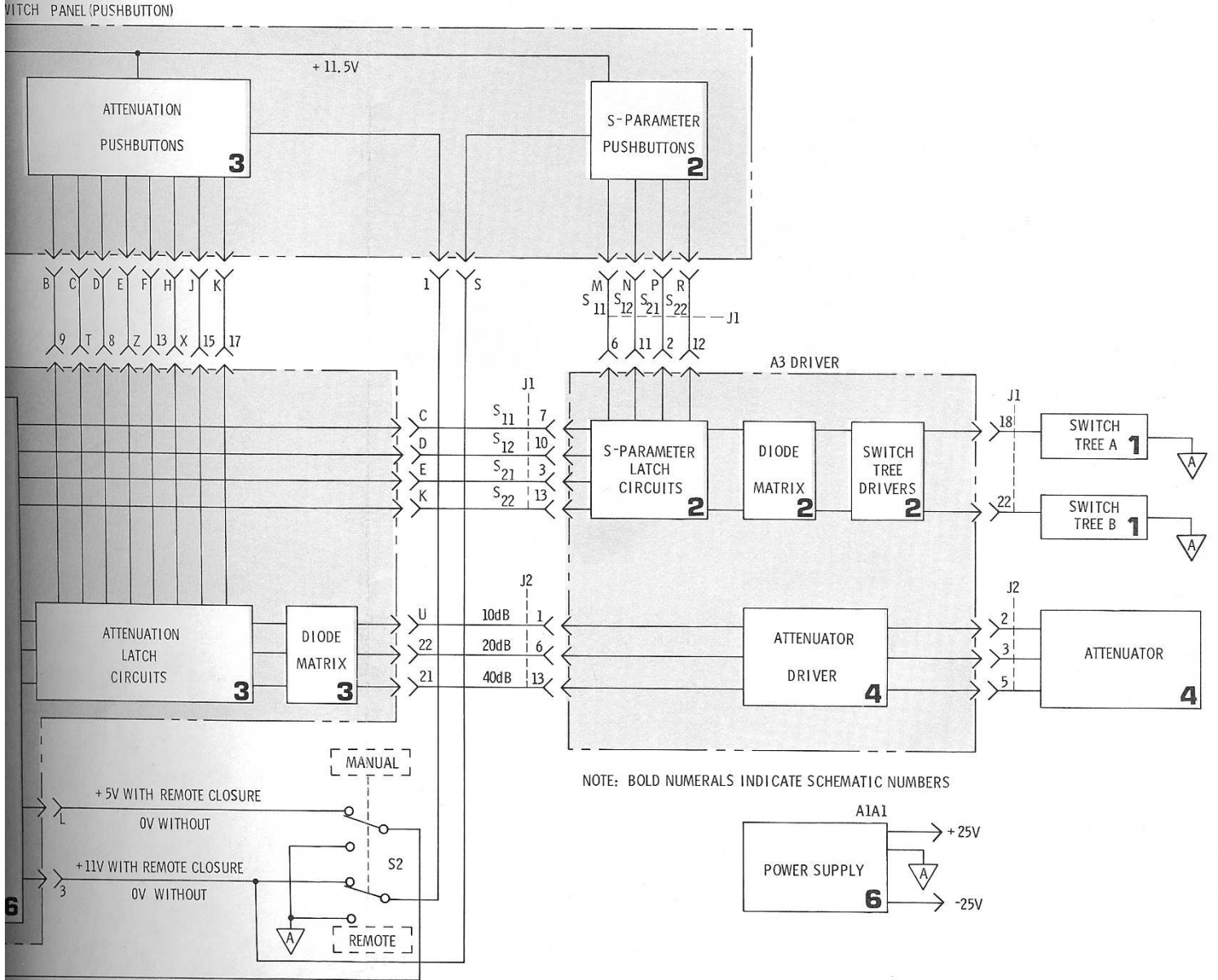

Figure 8-7. Index Block Diagram & Interconnection Diagram

8-17

SERVICE SHEET 1

RF CIRCUITS

The RF circuits of the Model 8746B consist of coaxial directional couplers, a line stretcher, an attenuator and s-parameter switch trees with connecting coaxial cables. Each switch tree consists of three coaxial switches which are energized at the same time. When energized, the center relay of the switch tree moves to one side while both outer relays energize to the opposite side. When properly energized, the action of these switches permits measuring all four s-parameters of an unknown, without moving the unknown, as follows:

S_{11} Reflection at PORT 1

S_{12} Transmission from PORT 2 to PORT 1 (reverse gain)

S_{21} Transmission from PORT 1 to PORT 2 (forward gain)

S_{22} Reflection at PORT 2.

A positive driver output causes a switch tree to switch to one side or an attenuator section (10 dB, 20 dB, 40 dB) to switch in. A negative driver output will cause the switch tree to switch to the opposite side or the attenuator section to switch out of the RF path.

Referring to Schematic 1, note that connections from the switch trees to A6 Attenuator and TEST output are interchanged in Options 001 and 002 from the connections in the standard model. For the standard model, the RF input into the PORT 1 and PORT 2 couplers is connected to the auxiliary line. For Options 001 and 002, the RF input into the PORT 1 and PORT 2 couplers is connected to the mainline. For the standard model, the RF output to the TEST channel comes from the mainline of the coupler. For Options 001 and 002, the RF output to the TEST channel comes from the auxiliary line of the coupler.

In addition to interchanging the input and output connections, the signal levels to the device under test are different with the various options. For both the standard model and Option 001, the signal through the mainline section of the PORT 1 & 2 couplers is attenuated 10 dB. In Option 002, there is no attenuation in the mainline section of the coupler. The reference channel coupler does not have any attenuation in either the standard or Option 001 or 002 versions. However, both the standard and Options 001 and 002 versions have 10 dB attenuation in the line stretcher. Coupling for all couplers (including reference channel coupler) in both standard models and Options 001 and 002 is nominally 20 dB.

HP 8746b 0.5-12.4 GHz S-parameter test-set

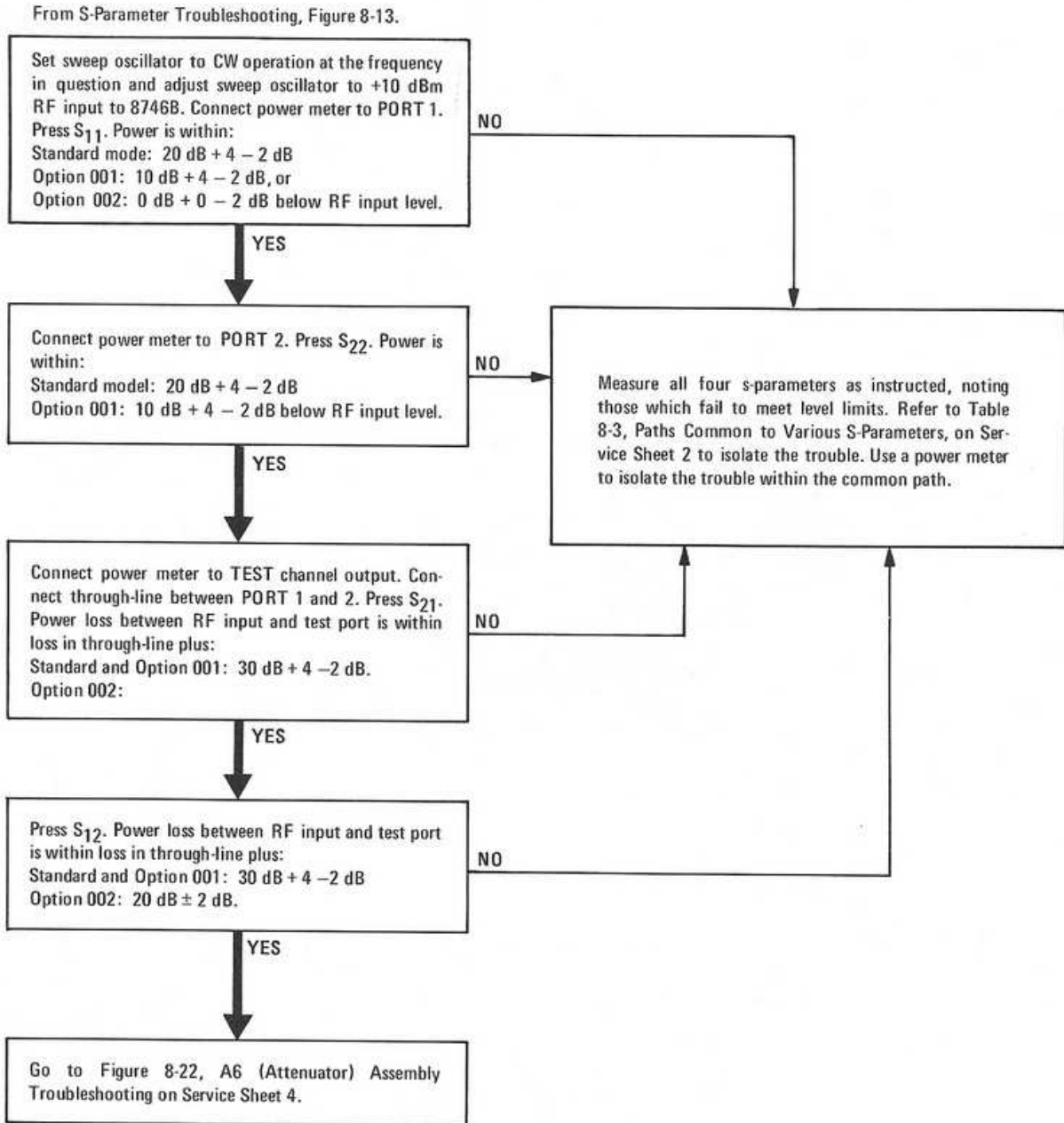

Figure 8-8. RF Troubleshooting

HP 8746b 0.5-12.4 GHz S-parameter test-set

Table 8-3. Paths Common to Various S-Parameter Switch Positions

From Test Channel Troubleshooting

Trouble in the 8746B test channel can be isolated to an RF path by determining in which switch positions the trouble occurs. The following table indicates locations of trouble by indicating common components. To use the table, set up equipment for calibration. Press the various s-parameter pushbuttons and note in which s-parameter positions a malfunction occurs. After location of trouble has been narrowed down, continue with the troubleshooting tree at the bottom of the page.

TROUBLE COMMON TO S-PARAMETERS	STANDARD MODEL ONLY	OPTIONS 001 & 002 ONLY	SPECIAL NOTE DC3, W4, A6, W5 and W9 are com- mon to ALL S- Parameter positions
	COMMON PATH WITH LOCATION OF TROUBLE	COMMON PATH WITH LOCATION OF TROUBLE	
S ₁₁ and S ₁₂	W8, A8S1, A8S2, and DC1	W7, A7S1, A7S2, and DC1	
S ₁₁ and S ₂₁	W7, A7S1, A7S2, and DC1	W8, A8S1, A8S2, and DC1	
S ₂₂ and S ₁₂	W11, A7S2, A7S3, and DC2	W10, A8S2, A8S3, and DC2	
S ₂₂ and S ₂₁	W10, A8S2, A8S3, and DC2	W11, A7S2, A7S3, and DC2	

Note the display indication. Press some other S-PARAMETER push-button. Press the original push-button. Trace within .05 dB of original trace.

NO

 Troubleshoot switches and switch connectors in the common trouble path.

↓ YES

Troubleshoot the common trouble path with an ohmmeter (no test channel signal) or a Time Domain Reflectometer (small insertion loss or discontinuity).

SE

HP 8746b 0.5-12.4 GHz S-parameter test-set

Service

Model 8746B

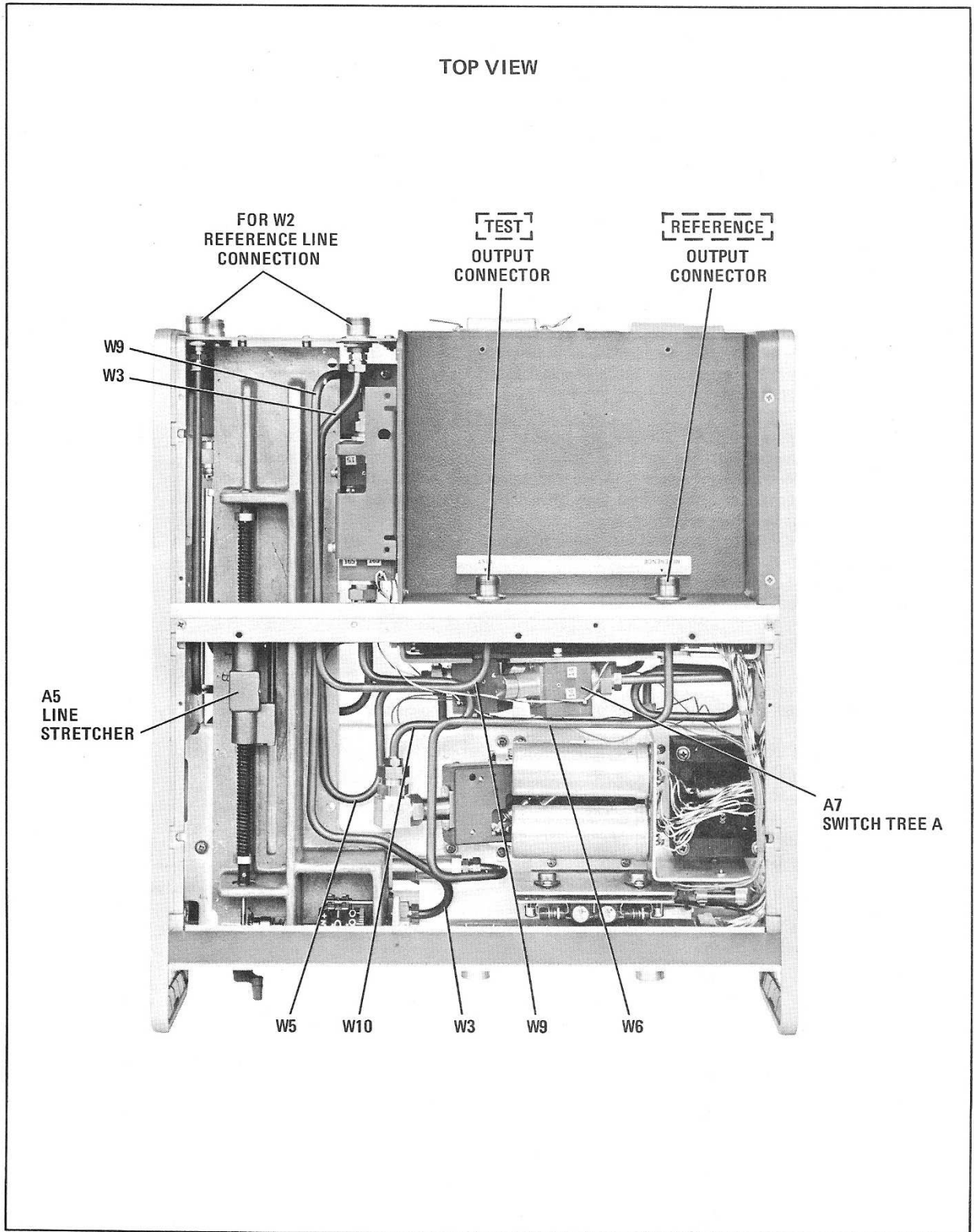

Figure 8-9. RF Circuitry, Top View

8-18

HP 8746b 0.5-12.4 GHz S-parameter test-set

Model 8746B

BOTTOM VIEW

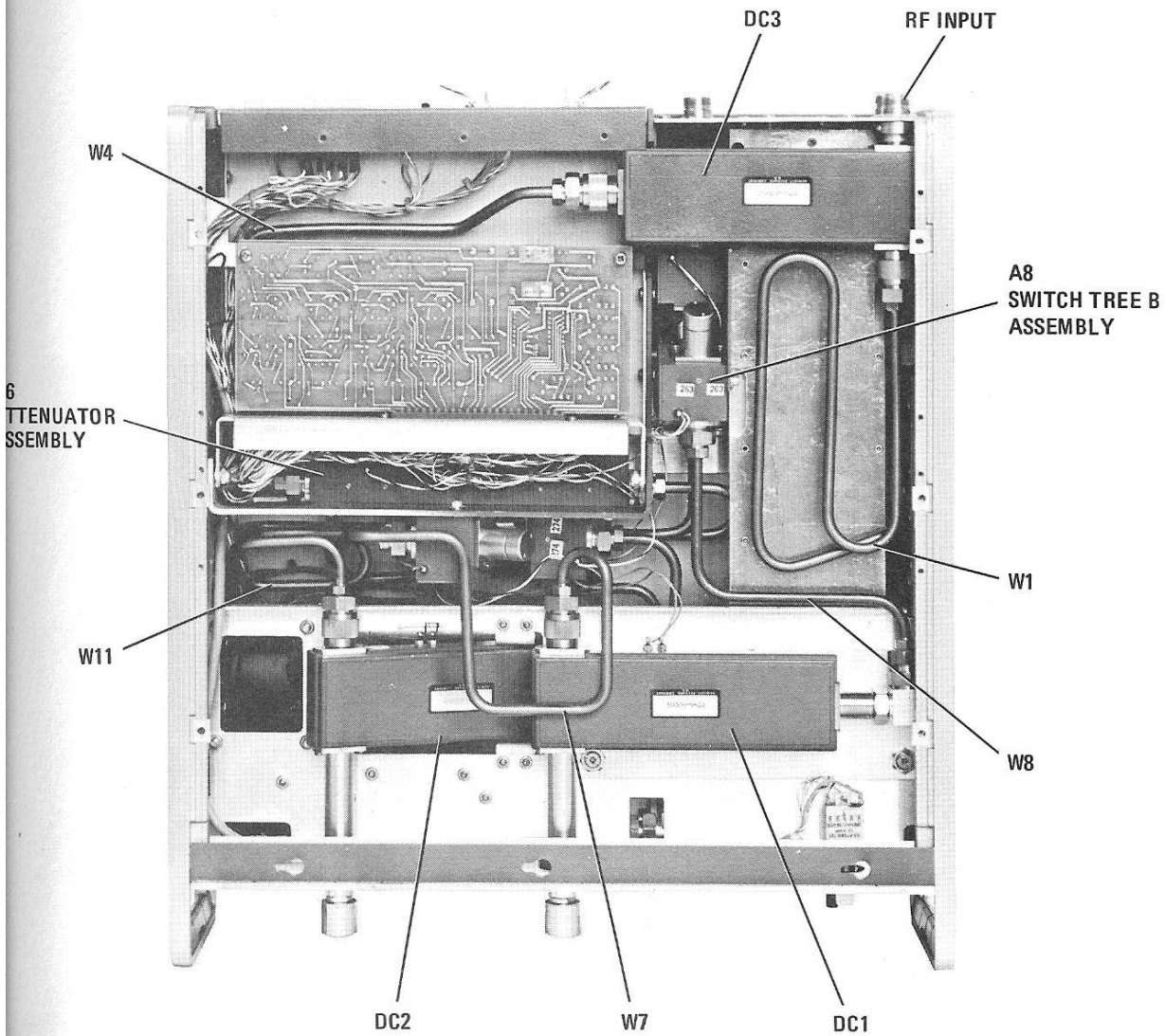

Figure 8-10. RF Circuitry, Bottom View

SERVICE
HEET 1

HP 8746b 0.5-12.4 GHz S-parameter test-set

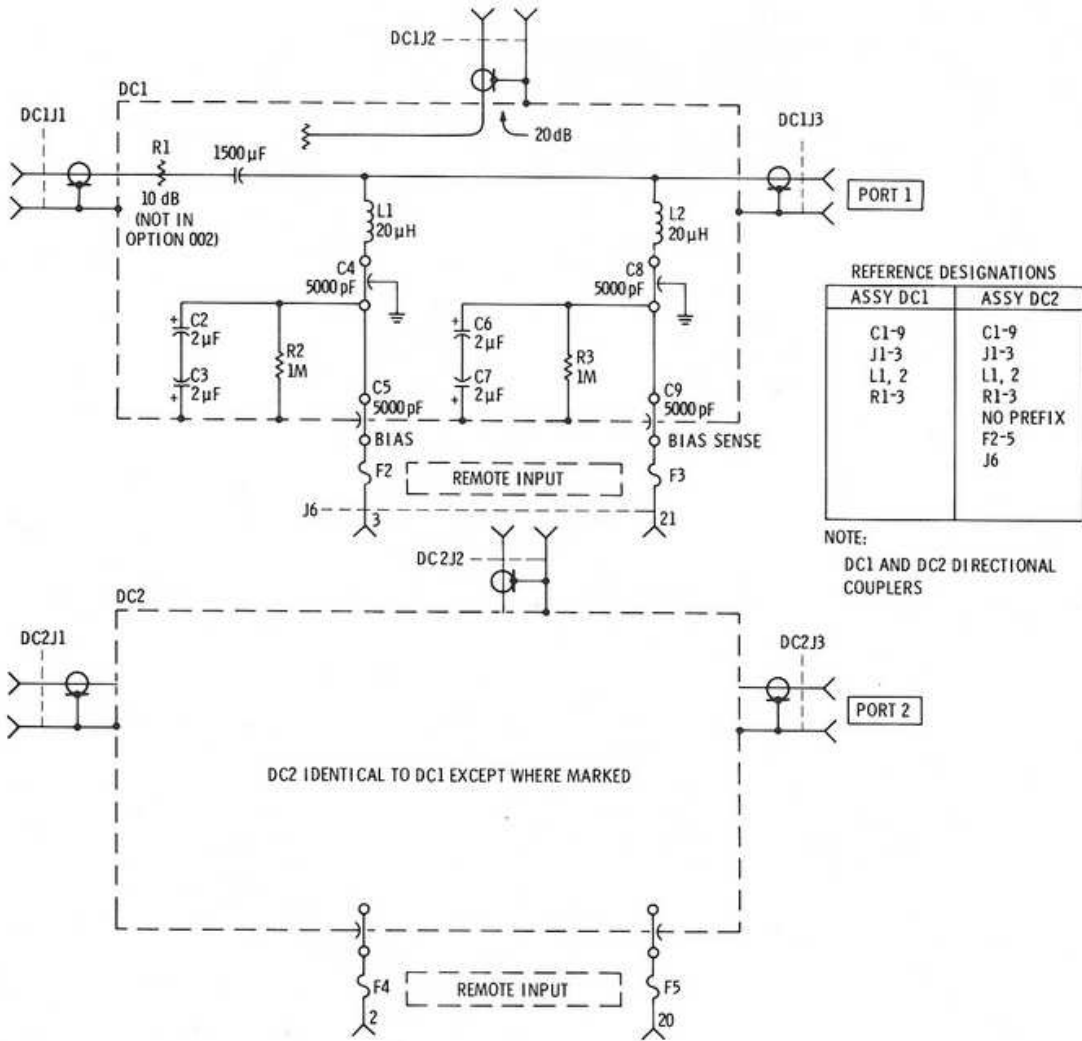
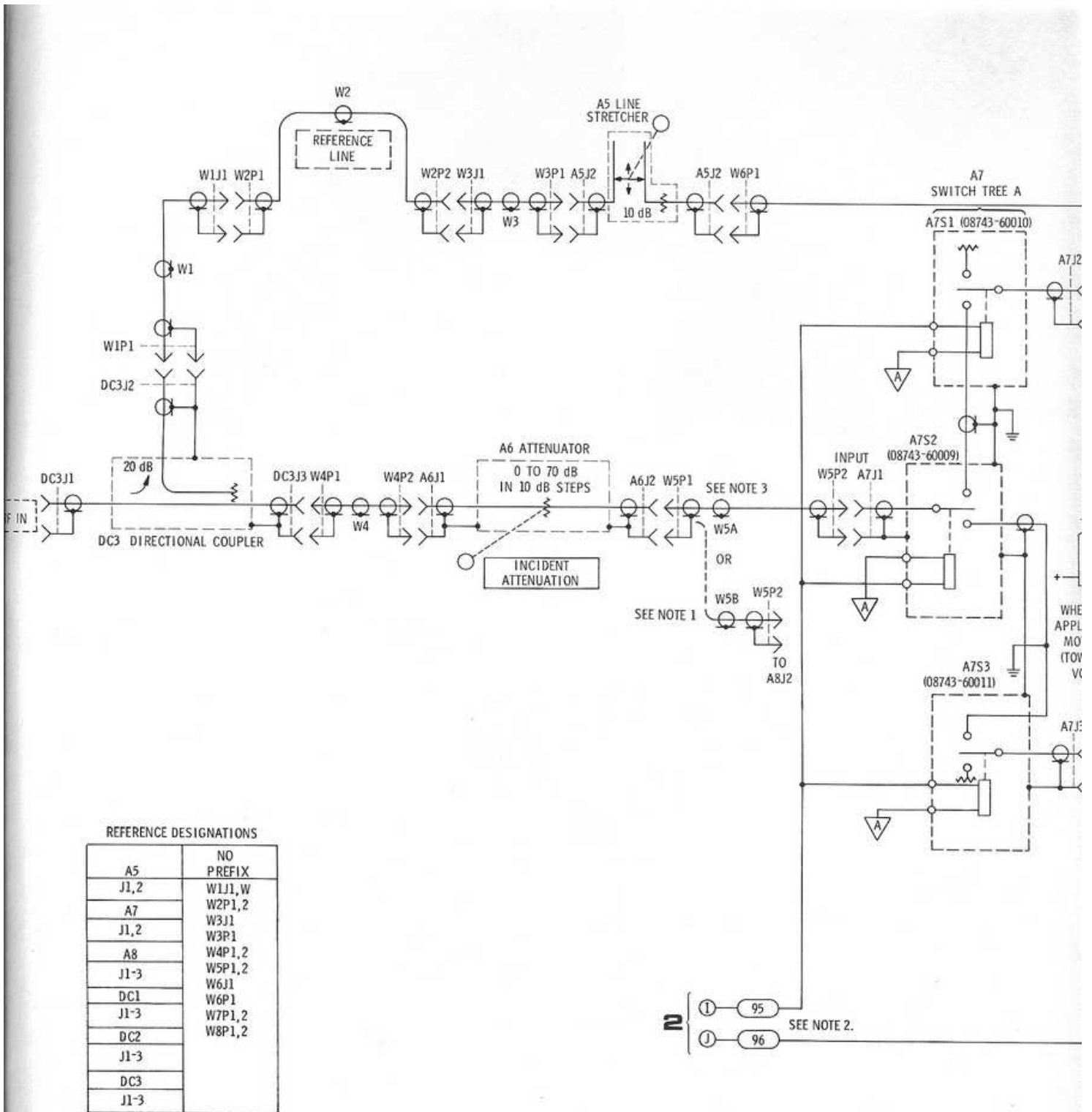

Figure 8-11. PORT 1 and PORT 2 Coupler

HP 8746b 0.5-12.4 GHz S-parameter test-set



REFERENCE DESIGNATIONS

NO	PREFIX
A5	W1J1, W2P1, 2
A7	W3J1, W3P1
A8	W4P1, 2
J1-3	W5P1, 2
DC1	W6P1
J1-3	W7P1, 2
DC2	W8P1, 2
J1-3	
DC3	
J1-3	

NOTES:

1. OPTIONS 001, 002 ONLY.
2. REVERSE THESE WIRES FOR OPTIONS 001 AND 002.
3. STANDARD MODEL ONLY.

HP 8746b 0.5-12.4 GHz S-parameter test-set

Service

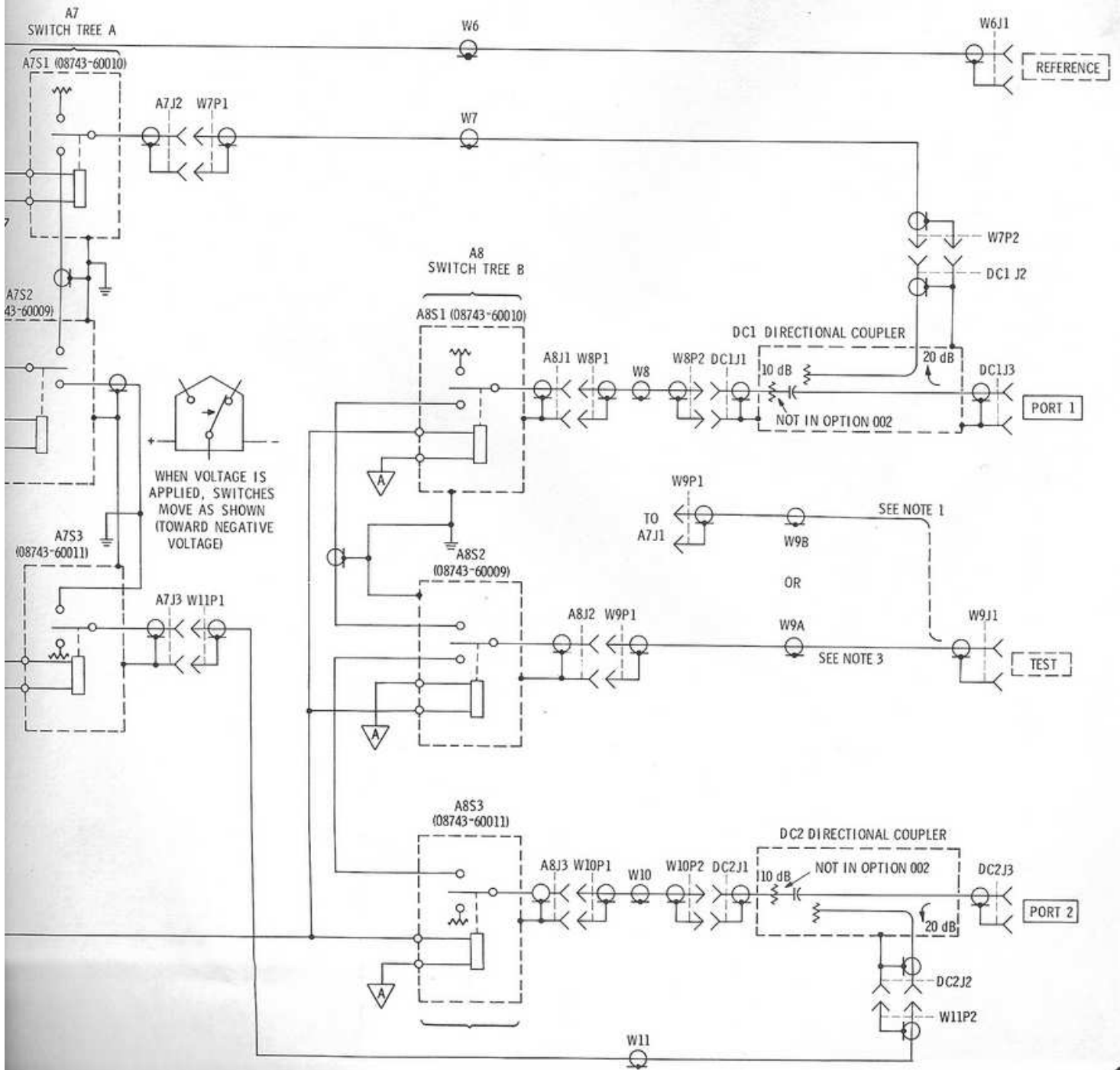

RF CIRCUITS

A5, A6, A7, A8

Figure 8-12. RF Circuit

8-19

SERVICE SHEET 2

S-PARAMETER LATCHING AND DRIVER CIRCUIT DESCRIPTION

Control circuitry for each s-parameter or attenuation selection consists of a pushbutton circuit, a remote-input circuit, and a transistor latching circuit with an associated diode matrix (not present in S₂₂ or 0 dB circuits) feeding associated driver circuits. When latched, the latch circuit provides a +6 volt signal to the diode matrix, which feeds this signal to the proper driver(s). Each driver actuates one or more switch relays. See RF Circuitry description on Service Sheet 1 for further information concerning RF circuitry.

LATCH CIRCUITRY

Each latch circuit consists of a pair of direct-coupled complementary transistors, together with associated front-panel pushbutton or remote input and an indicator lamp.

Referring to Schematic 2, note that when the instrument is first turned on, zener diode A3CR9 (S₂₂ circuit) conducts, turning transistor A3Q8 on. The collector current of A3Q8, flowing through A3R17, will cause the base of A3Q7 to go positive. This action turns A3Q7 on. Collector current through A3Q7 will lower its collector voltage. This voltage, which is also applied to the base of A3Q8, will keep A3Q8 on, due to the regenerative action just described. When current flows through A3R8, the voltage drop across A3CR9 drops below 10V and the diode no longer conducts. There is no connection from S₂₂ latch circuit to the diode matrix since for S₂₂ all driver inputs should be low.

In the manual mode, the A4 pushbutton buss is at common potential. When a pushbutton other than S₂₂ (say S₁₁) is pushed, common (0 volts) is applied to the base of A3Q2 through A3CR1 and A3R1. Transistor A3Q2 turns on, which turns on A3Q1 through the regenerative action previously described. The additional current drawn by A3Q1 flows through the common emitter-resistor A3R8. The voltage on the common emitter-resistor buss raises sufficiently to cut off all latch circuits except the one whose pushbutton is actuated.

The latching circuit output is applied to the diode matrix, A3CR10 through A3CR13, and thus to the switch tree drivers. For example, when S₁₁ is selected, transistor A3Q2's collector is at about +6 volts, which biases on A3CR11 and A3CR12. The +6 volts is then applied to both switch tree drivers.

In remote operation, +11 volts is applied to the pushbutton buss, so that A3CR1, 3, 5 and 7 cannot conduct, thus disabling the pushbuttons.

DRIVER CIRCUITRY

The +6 volt signal from the diode matrix is supplied to the selected drivers. All drivers are identical, so only the driver feeding Switch Tree A will be explained. Other switch tree drivers operate in a similar manner.

The switch tree and attenuator relays are two-position, magnetically latched relays. Their position depends upon the direction of current flow through their coils. The three coils are in parallel and energize simultaneously. Referring to Switch Tree A Driver, only one of the input transistors, A3Q11 or A3Q12, will conduct at any one time. The bases and emitters of these transistors are tied together. The voltage divider in the emitter circuit maintains emitter voltage at about +2 volts. When the input to A3R18 is raised to +6 volts, transistor A3Q12 is turned on. Turning A3Q12 on causes A3CR14 to conduct, providing a low emitter impedance which allows A3Q12 to saturate. Transistor A3Q12's collector current provides base current to A3Q13, which turns A3Q13 on. The driver output will begin to rise toward +25

SERVICE SHEET 2 (cont'd)

volts. As the output voltage rises through A3R22) to the base of A3Q14 harder. This regenerative action between A3Q12 and A3Q13 are saturated. When about +24 volts, the switch trees at this voltage causes A3Q12/A3Q13 to saturate and to conduct, which reverses the polarity of the output voltage. Current through the switch trees actuate in the reverse direction. As the output voltage rises in the reverse current also reverses direction. As the output voltage rises in the reverse direction, the conducting transistor is held on until the voltage across the switch trees reaches a range of $\approx +3$ volts to $\approx +5$ volts from switching on noise.

Diodes A3CR16 and A3CR17 provide a protective voltage caused by the relay's switching action. Diodes A3CR16 and A3CR17 protect the driver of the current through and voltage across the output transistors from becoming excessive.

HP 8746b 0.5-12.4 GHz S-parameter test-set

2 (cont'd)

put voltage rises, feedback (dashed line) to the base of A3Q12 will turn A2Q12 on. Repetitive action will continue until A3Q12 is saturated. When the driver output reaches the switch trees actuate. Removing the input to A3Q12/A3Q13 to shut off and A3Q11/A3Q10 reverses the polarity of the driver's output. The polarity of the switch tree relays is reversed and they actuate in the reverse direction. Feedback in the reverse direction. As feedback current is changing, the conducting transistor, A3Q11 or A3Q12, is turned off. The voltage across A3R18 passes through the diodes to $\approx +5$ volts, preventing the relay driver from oscillating.

and A3CR17 provide a path for the induced current by the relay's switching. Transistors A3Q9 and A3Q10 sense the driver output transistors by sensing the current and voltage across the output transistors and turn the output transistors off if the current becomes too high.

From Preliminary Troubleshooting, Figure 8-2.

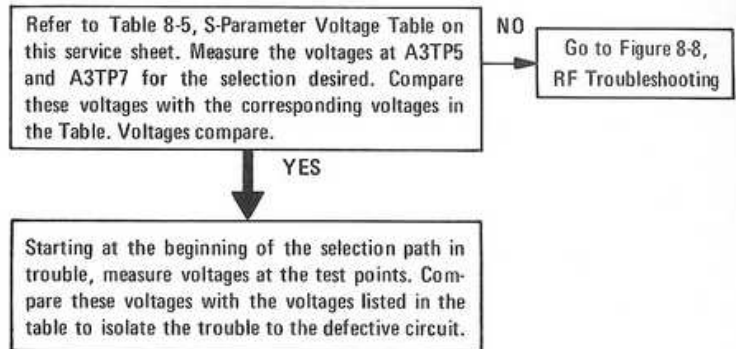

Figure 8-13. S-Parameter Troubleshooting

Table 8-4. S-Parameter Truth Table

PARAMETER	SWITCH TREES (Standard Model Only)	
S_{11}	A High	B High
S_{12}	Low	High
S_{21}	High	Low
S_{22}	Low	Low
PARAMETER	SWITCH TREES (Opts. 001 and 002 Only)	
S_{11}	A High	B High
S_{12}	High	Low
S_{21}	Low	Low
S_{22}	Low	Low
NOTE		
High = $> +6V$ input to Driver and $> +24V$ output from Driver.		
Low = $< +2V$ input to Driver and $< -24V$ output from Driver.		

HP 8746b 0.5-12.4 GHz S-parameter test-set

Table 8-5. S-Parameter Voltage Table

PARAMETER	P1 PIN 7	P1 PIN 10	P1 PIN 3	P1 PIN 13	TP 1	TP 2	TP 3	TP 4	TP 5	TP 6	TP 7
S ₁₁	≤+1V	≥+9V	≥+9V	≥+9V	≤+2V	≥+6V	≤+2V	≥+6V	≥+23.3V*	≥+6V	≥+23.2V
S ₁₂	≥+9V	≤+1V	≥+9V	≤+1V	≤+2V	≤+2V	≥+6V	≤ 0V	≤-23.2V*	≥+6V	≥+23.3V*
S ₂₁	≥+9V	≥+9V	≤+1V	≥+9V	≥+6V	≤+2V	≤+2V	≥+6V	≥+23.3V*	≤ 0V	≥-23.3V*
S ₂₂	≥+9V	≥+9V	≥+9V	≥+9V	≤+2V	≤+2V	≤+2V	≤ 0V	≤-23.3V*	≤ 0V	≤-23.3V*

NOTE: The voltages shown on P1 will occur only *while* s-parameter pushbutton is being depressed. All voltages are measured to common (any white-black wire), NOT CHASSIS GROUND.

* A more accurate check consists in measuring the voltage drop across the saturated output transistor. The saturated transistor is the 1854-0012 output transistor on the schematic for an input voltage of ≥ +2V. The voltage (collector-emitter) across the saturated output transistor should not exceed 1.2 volts.

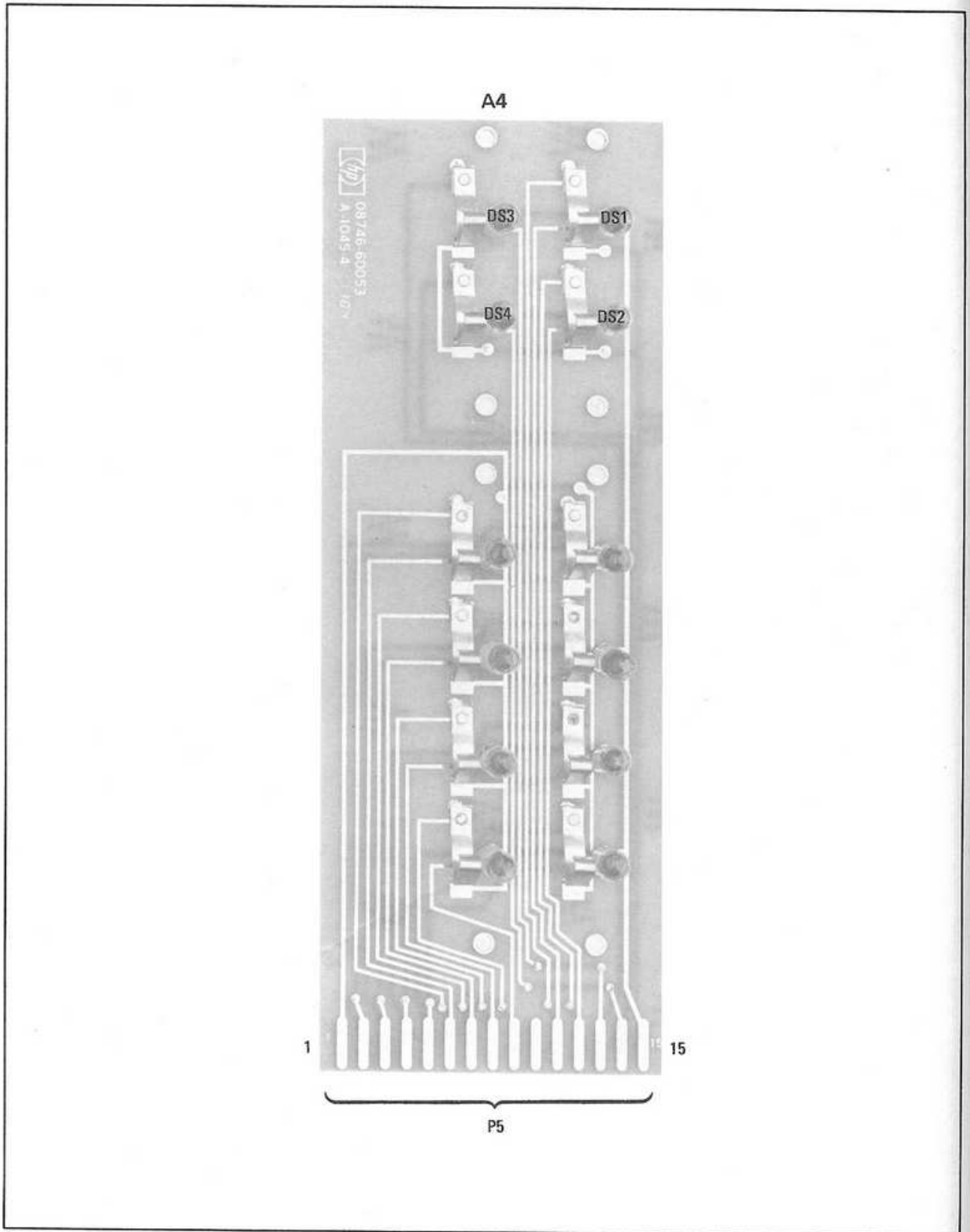

Figure 8-14. A4 Switch Panel Assembly, Parts Location

HP 8746b 0.5-12.4 GHz S-parameter test-set

Model 8746B

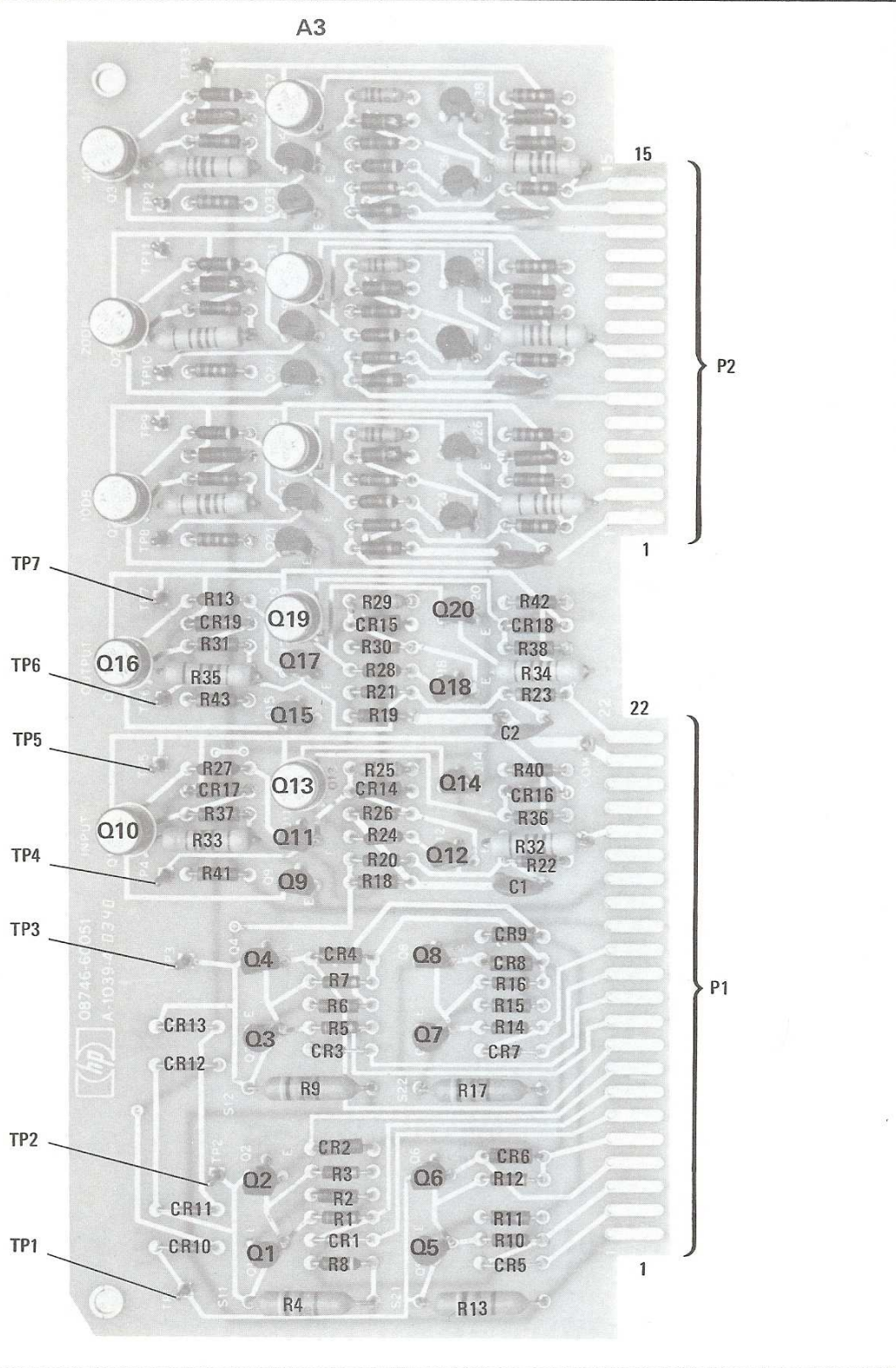
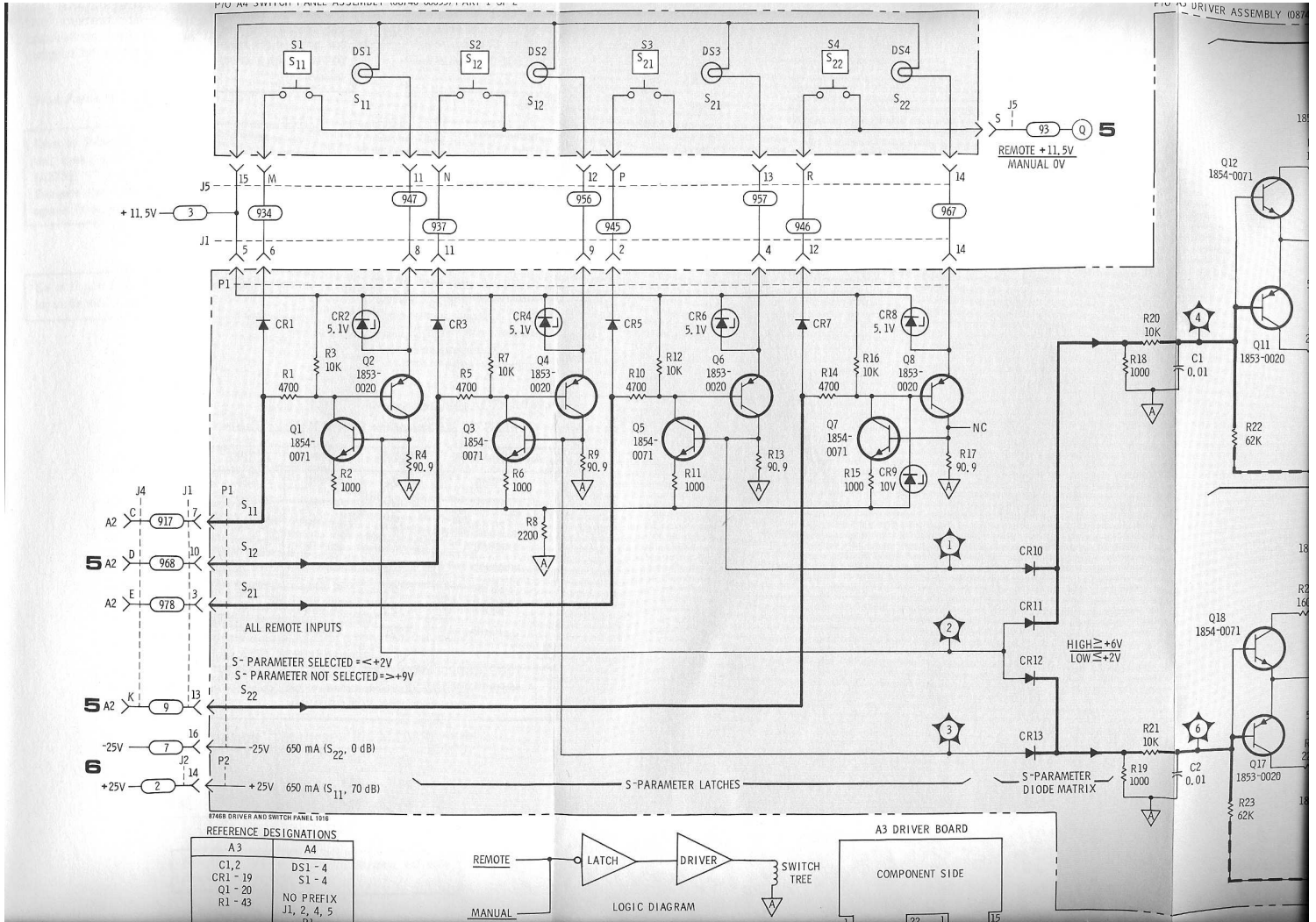

Figure 8-15. A3 Driver Assembly, Parts Location

SERVICE SHEET 2

HP 8746b 0.5-12.4 GHz S-parameter test-set



SERVICE SHEET 3

ATTENUATION SELECT LATCHING AND DRIVER CIRCUIT DESCRIPTION

Control circuitry for each attenuation selection consists of a pushbutton circuit and a latching circuit with associated diode matrix (not present in 0 dB circuits) feeding associated driver circuits. The latch circuit provides a +6 volt signal to the diode matrix, which feeds this signal to the proper driver(s). Each driver actuates an attenuator relay.

LATCH CIRCUITRY

Each latch circuit consists of a pair of direct-coupled complementary transistors, together with associated front-panel pushbutton and indicator lamp. The circuit acts like a multivibrator in that the transistors at any one time are either saturated (latched) or turned off. However, turning off the transistors is accomplished in a different manner than in multivibrators, as is explained in the following paragraph.

Referring to Schematic 3, note that when the instrument is first turned on, zener diode A2CR26 (70 dB circuit) conducts, turning transistor A2Q16 on by lowering the base voltage. The collector current of A2Q16, flowing through A2R33, will cause the base of A2Q15 to go positive. This action turns A2Q15 on. Collector current through A2Q15 will lower its collector voltage. This voltage, which is also applied to the base of A2Q16, will keep A2Q16 on, due to the regenerative action just described. When current flows through A2R8, the voltage drop across A2CR26 drops below 10V and the diode no longer conducts.

In the manual mode, the A4 pushbutton buss is at common potential. When a pushbutton other than 70 dB (say 10 dB) is pushed, common (0 volts) is applied to the base of A2Q4 through A2R5. Transistor A2Q4 turns on, which turns on A2Q3, through the regenerative action just described. The additional current drawn by A2Q3 flows through the common emitter-resistor A2R8. The voltage on the emitter buss raises sufficiently to cut off all latch circuits except the one whose pushbutton is actuated.

The latching circuit output is applied to the diode matrix (A2CR5, A2CR8, A2CR11, A2CR12, A2CR15, A2CR18, A2CR19, A2CR22, A2CR23, and A2CR27 through A2CR29). This matrix applies the signal to the proper switch drivers. For example, when 10 dB is selected, transistor A2Q4's collector is at about +6 volts, which biases A2CR5 on. The +6 volts is thus applied to the 10 dB attenuator driver. There is no output circuit from the 0 dB latch circuit to the Attenuator Drivers since 0 dB is selected at the Attenuator whenever there is no latching circuit input to the Attenuator.

In remote operation, +11 volts is applied to the pushbutton buss, which disables the pushbuttons. (Circuit description continued at Attenuator Driver Description on Service Sheet 4.)

HP 8746b 0.5-12.4 GHz S-parameter test-set

From Preliminary Troubleshooting, Figure 8-2.

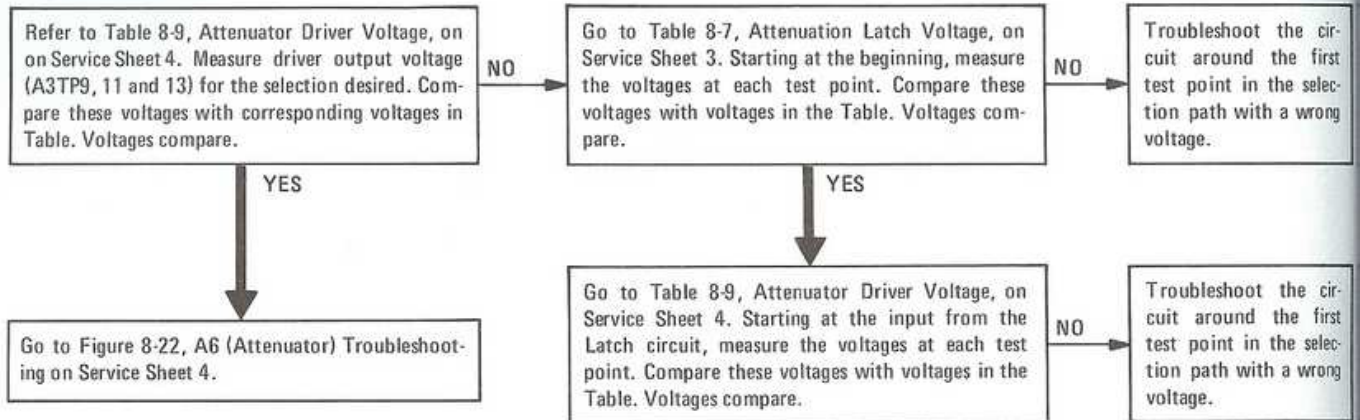

Figure 8-17. Attenuation Select Troubleshooting

Table 8-6. Attenuator Truth Table

ATTENUATION	10 dB	20 dB	40 dB
0 dB	False	False	False
10 dB	True	False	False
20 dB	False	True	False
30 dB	True	True	False
40 dB	False	False	True
50 dB	True	False	True
60 dB	False	True	True
70 dB	True	True	True

True = Attenuator section in RF path.
False = Attenuator section not in RF path.

Table 8-7. Attenuation Latch Voltage Table

ATTENUATION	A2TP9	A2TP10	A2TP11
0 dB	≤+2V	≤ +2V	≤+2V
10 dB	≥+5V	≤ +2V	≤+2V
20 dB	≤+2V	≤ +5V	≤+2V
30 dB	≥+5V	≥ +5V	≤+2V
40 dB	≤+2V	≤ +2V	≥+5V
50 dB	≥+5V	≤ +2V	≥+5V
60 dB	≤+2V	≥ +5V	≥+5V
70 dB	≥+5V	≥ +2V	≥+5V

NOTE: All voltages are measured to common (any white-black wire), NOT GROUND.

HP 8746b 0.5-12.4 GHz S-parameter test-set

Service

Model 8746B

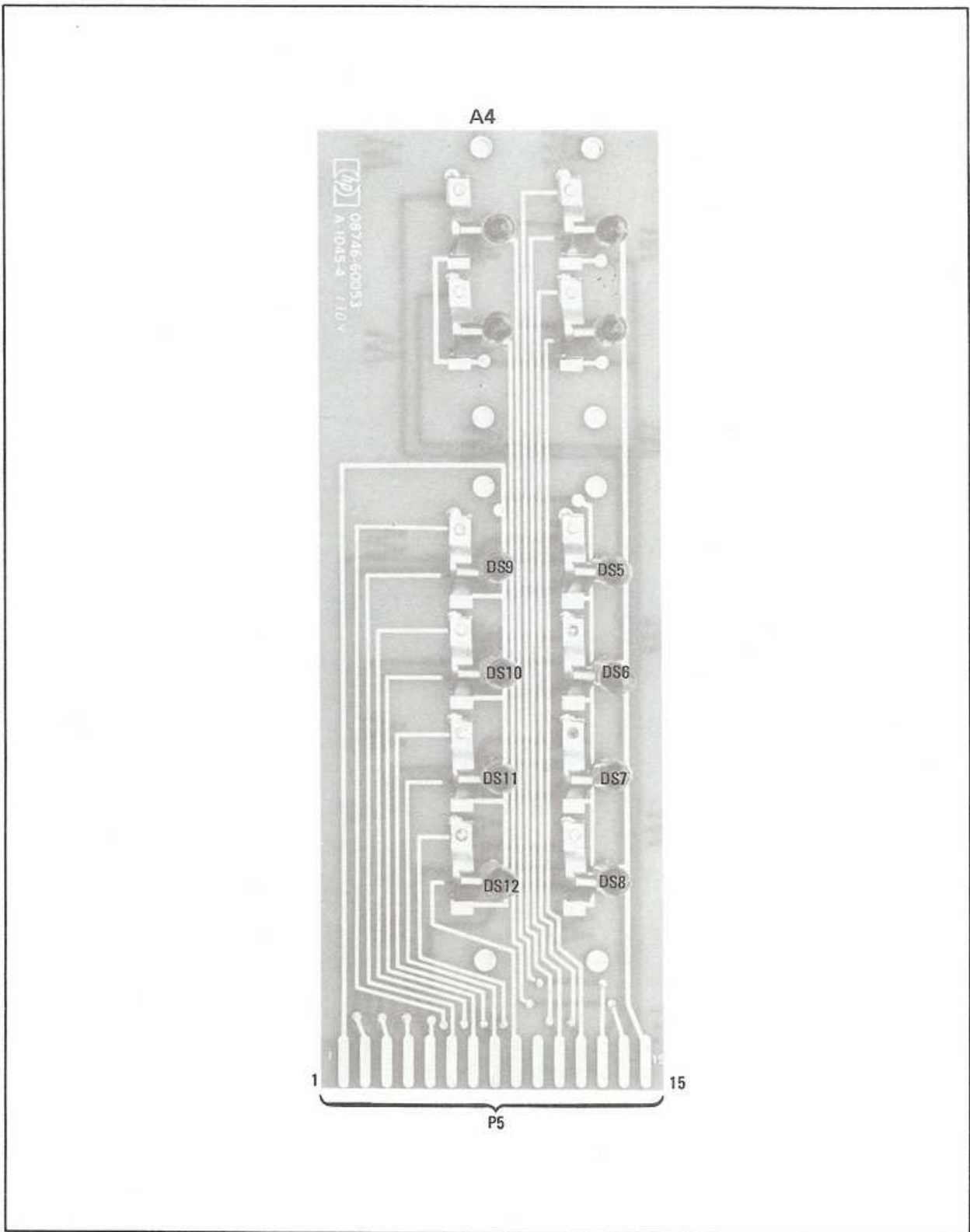

Figure 8-18. A4 Switch Panel Assembly Parts Location

8-22

HP 8746b 0.5-12.4 GHz S-parameter test-set

Model 8746B

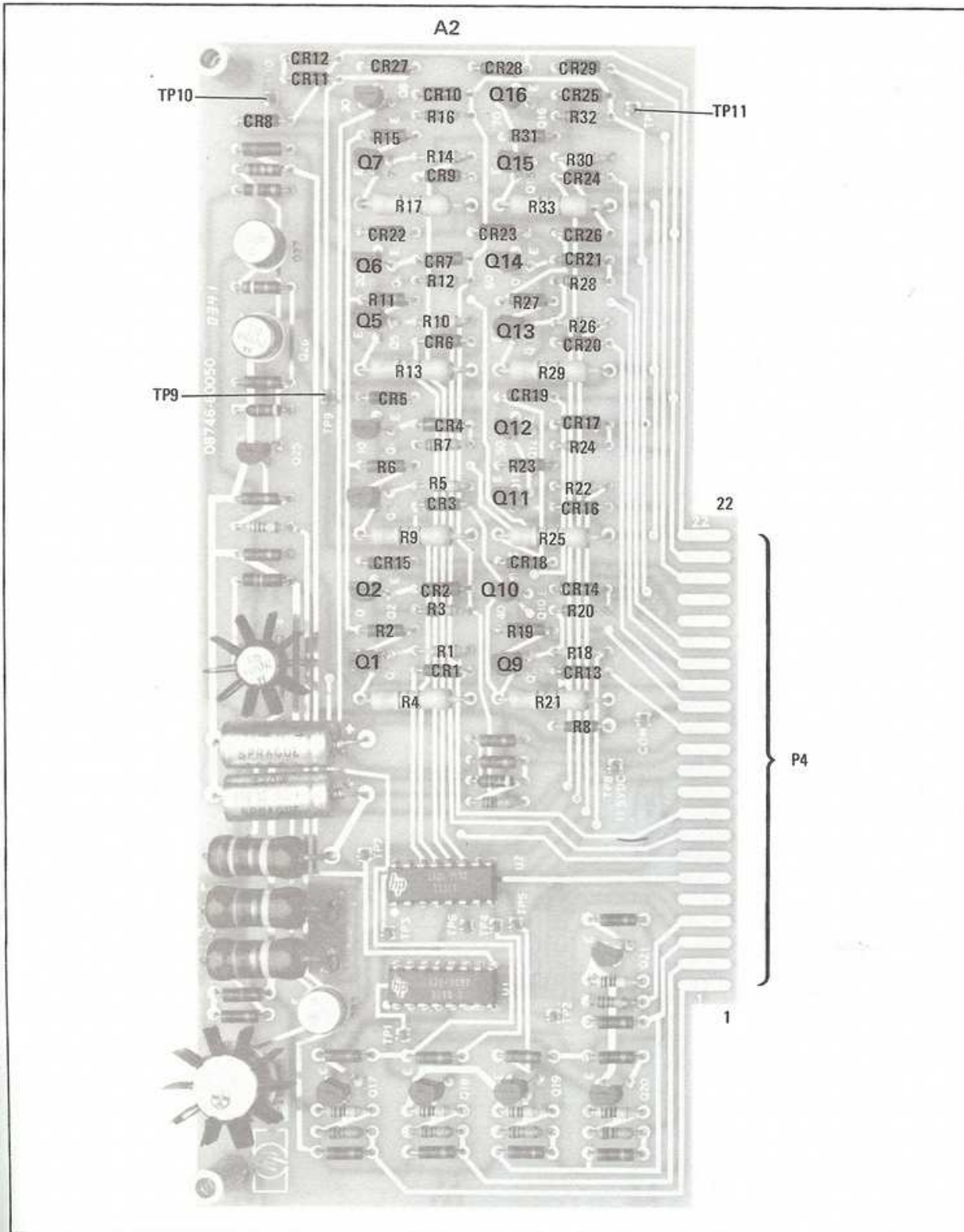
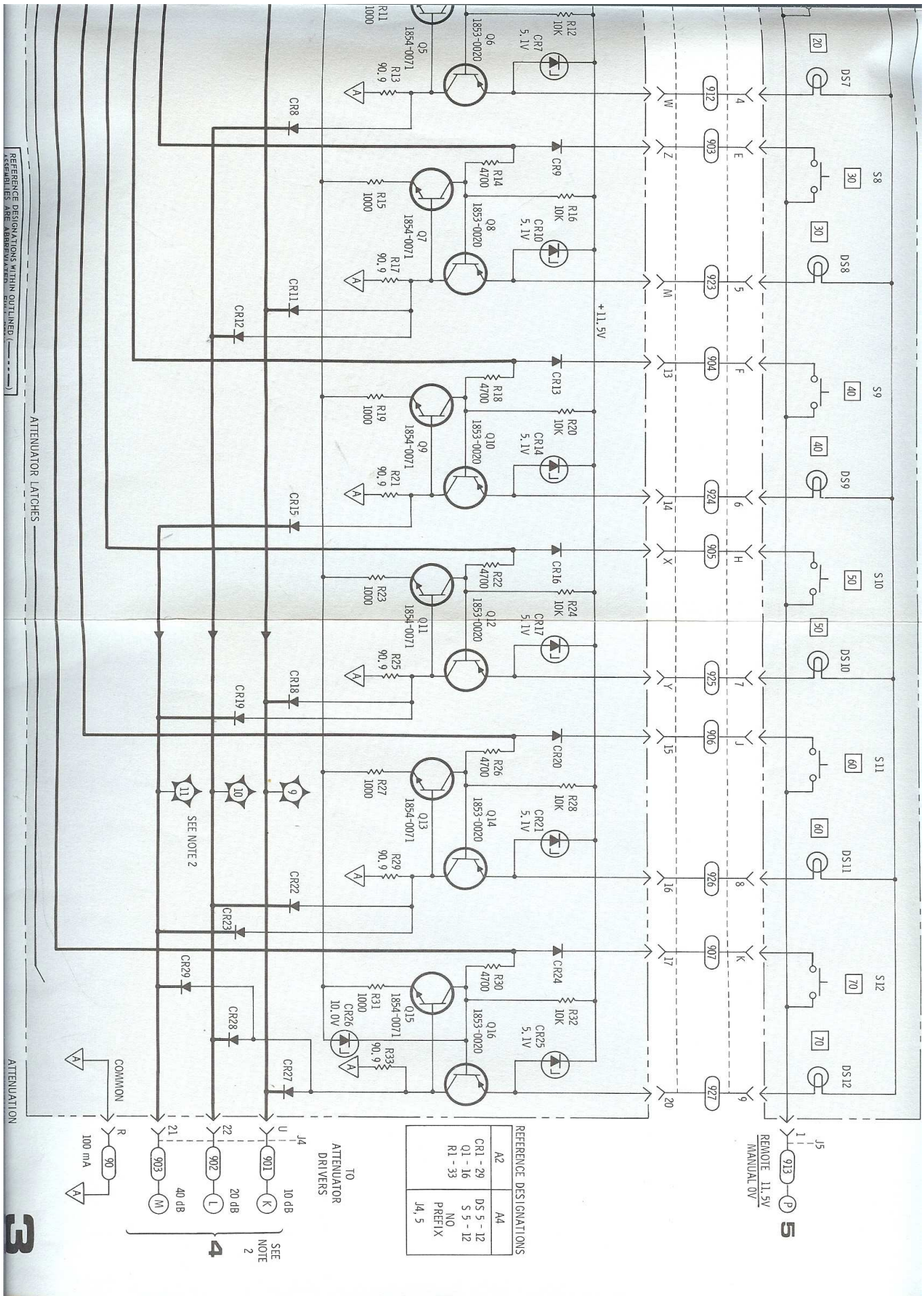

Figure 8-19. A2 Buffer Assembly, Parts Location

SERVICE SHEET 3

HP 8746b 0.5-12.4 GHz S-parameter test-set



HP 8746b 0.5-12.4 GHz S-parameter test-set

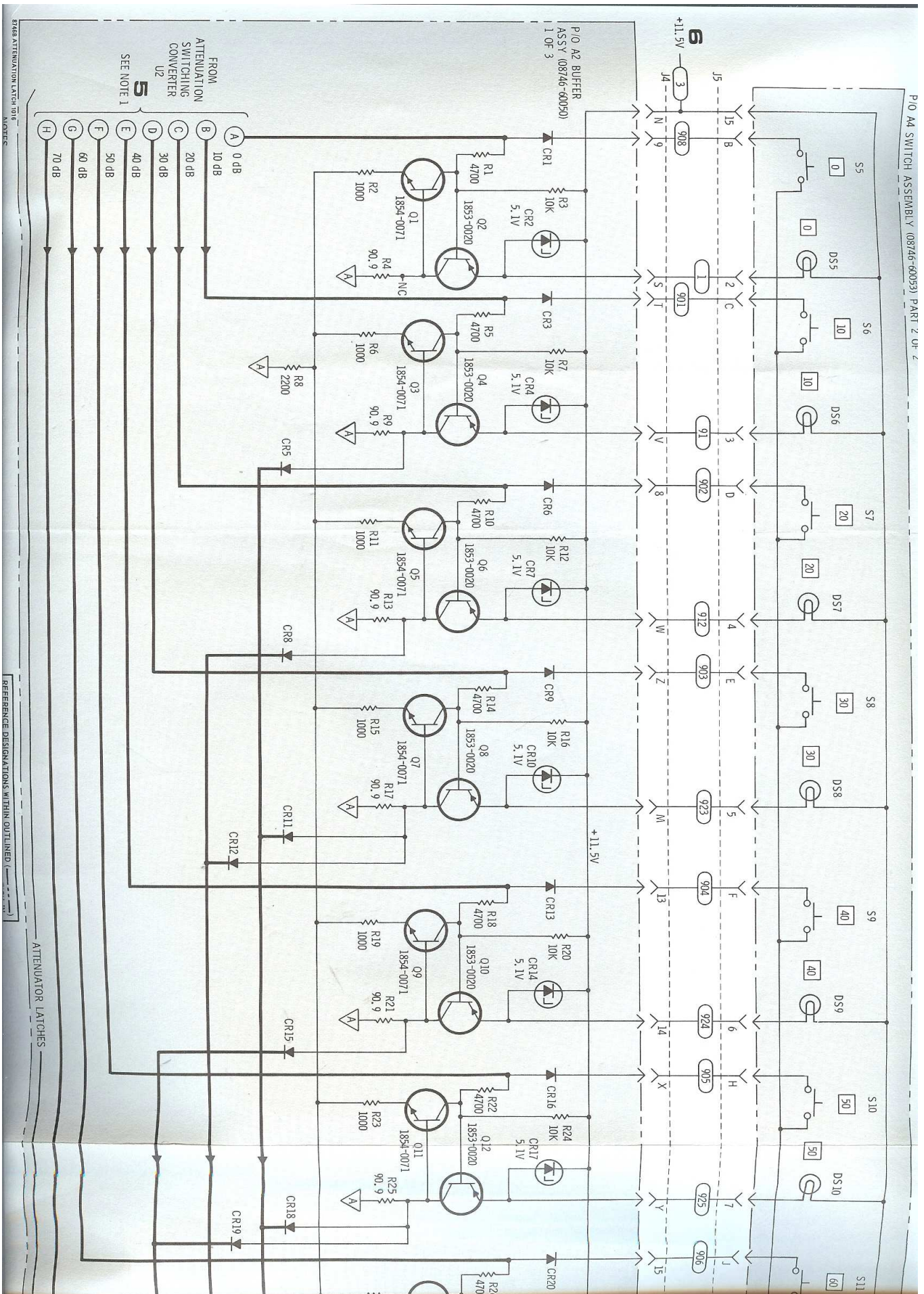

SERVICE SHEET 4

ATTENUATION LATCHING AND DRIVER CIRCUIT DESCRIPTION

Control circuitry for each 10 dB attenuation step consists of a pushbutton circuit, a transistor latching circuit with an associated diode matrix (not present in 0 dB attenuation step). The latch circuit provides a +6 volt signal to the diode matrix, which feeds this signal to the proper driver(s). Each driver actuates one or more attenuator relays.

LATCH CIRCUITRY

Each latch circuit consists of a pair of direct-coupled complementary transistors, together with associated front-panel pushbutton and indicator lamp.

Referring to Schematic 3, note that when the instrument is first turned on, zener diode A2CR26 (70 dB circuit) conducts, turning transistor A2Q16 on by lowering the base voltage. The collector current of A2Q16, flowing through A2R33, will cause the base of A2Q15 to go positive. This action turns A2Q15 on. Collector current through A3Q15 will lower its collector voltage. This voltage, which is also applied to the base of A2Q16, will keep A2Q16 on due to the regenerative action just described. When current flows through A2R8, the voltage drop across A2CR26 drops below 10V and the diode no longer conducts.

The latching circuit output is applied to the diode matrix (A2CR5, A2CR8, A2CR11, A2CR12, A2CR15, A2CR18, A2CR19, A2CR22, A2CR23, A3CR27, A2CR28, and A2CR29) and thus to the attenuator drivers. For example, when 70 dB is selected the collector of A2Q16 is at about +6V which biases on A2CR27, A2CR28, and A2CR29. The +6V is then applied to all attenuator relay drivers.

When the remote enable contact closure is closed and the REMOTE - MANUAL switch is in the REMOTE position, +11V is applied to the attenuator select pushbutton buss which disables the attenuation pushbuttons.

DRIVER CIRCUITRY

The +6 volt signal from the diode matrix is supplied to the selected drivers. All drivers are identical, so only the driver feeding the 10 dB attenuator switch will be explained. All attenuator driver circuits operate in a similar manner.

The switch tree and attenuator relays are two-position, magnetically-latched relays. Their position depends upon the direction of current flow through their coils. The three switches in the step attenuator operate independently in various combinations to give 0 to 70 dB attenuation in 10 dB steps.

Referring to the 10 dB driver on schematic 4, only one of the input transistors A3Q23 or A2Q24 will conduct at any one time. The bases and emitters of these transistors are tied together. The voltage divider and zener diode A3CR23 in the emitter circuit maintains emitter voltage at about +2 volts. When the input is raised to +6 volts, A2Q24 is turned on. Turning A3Q24 on causes A3CR23 to conduct, providing a low emitter impedance which allows A3Q24 to saturate. Transistor A3Q24's collector current provides base current to A3Q25, which turns A3Q25 on. The driver output will begin to rise toward +25 volts. As the output voltage rises, feedback (dashed line through A3R61) to the base of A3Q24 will turn A3Q24 on harder. This regenerative action will continue until A3Q24 and A3Q25 are saturated. When the driver output reaches about +24 volts the attenuator switch actuates. Removing the input voltage causes A3Q24/A3Q25 to shut off and A3Q23/A3Q22 to conduct, which reverses the polarity of the driver's output voltage. Current through the attenuator relay is reversed and the attenuator relay actuates again but in the opposite direction. The feedback current also reverses direction. As feedback current is changing direction, the conducting transistor A3Q23 or A3Q24 is held on until the voltage across A3R57 passes through the range of $\approx +3$ volts to $\approx +5$ volts, preventing the attenuator driver from switching on noise.

SERVICE SHEET 4

Diodes A3Q25 and voltage caused by the and A3Q26 protect the current through transistors and turn current becomes exc

From Preliminary Troubl

Refer to Table 8-9, Atten this service sheet. Meas (A3TP9, 11 and 13) f Compare these voltages ages in Table. Voltages cr

Go to Figure 8-22, A6 (ing on Service Sheet 4.

From Test

Determine calibration TEST CH/ VERNIER normal gai PORT 1. F for a 0 dB Zero dB ir change the Push the necessary specified a

INCIDENT

HP 8746b 0.5-12.4 GHz S-parameter test-set

SERVICE SHEET 4 (cont'd)

Diodes A3Q25 and A3Q26 provide a path for the inductive voltage caused by the relay's switching. Transistors A3Q21 and A3Q26 protect the driver output transistors by sensing the current through and voltage across the output transistors and turning the output transistors off if the current becomes excessive.

From Preliminary Troubleshooting, Figure 8-2.

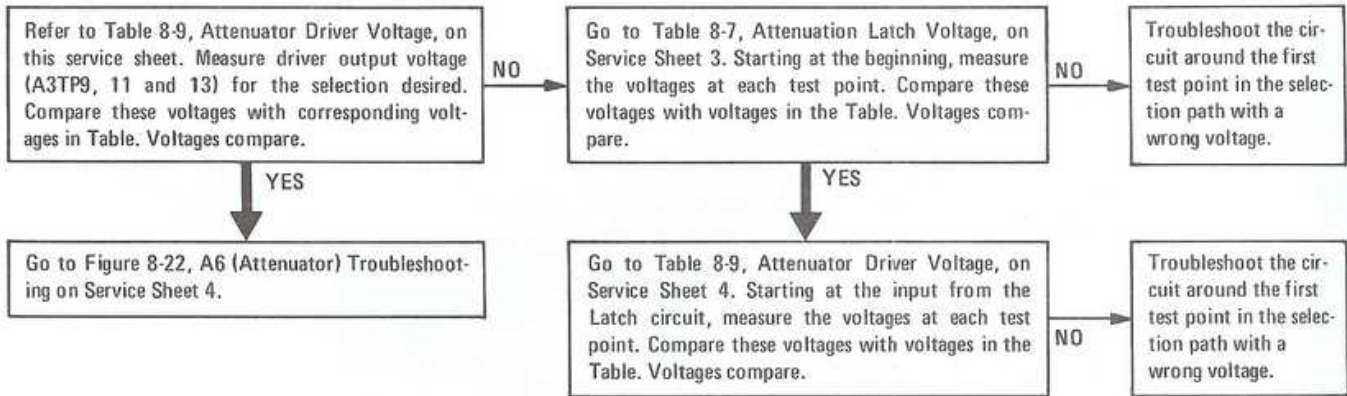

Figure 8-21. Attenuation Select Troubleshooting

From Test Channel Troubleshooting, Figure 8-4.

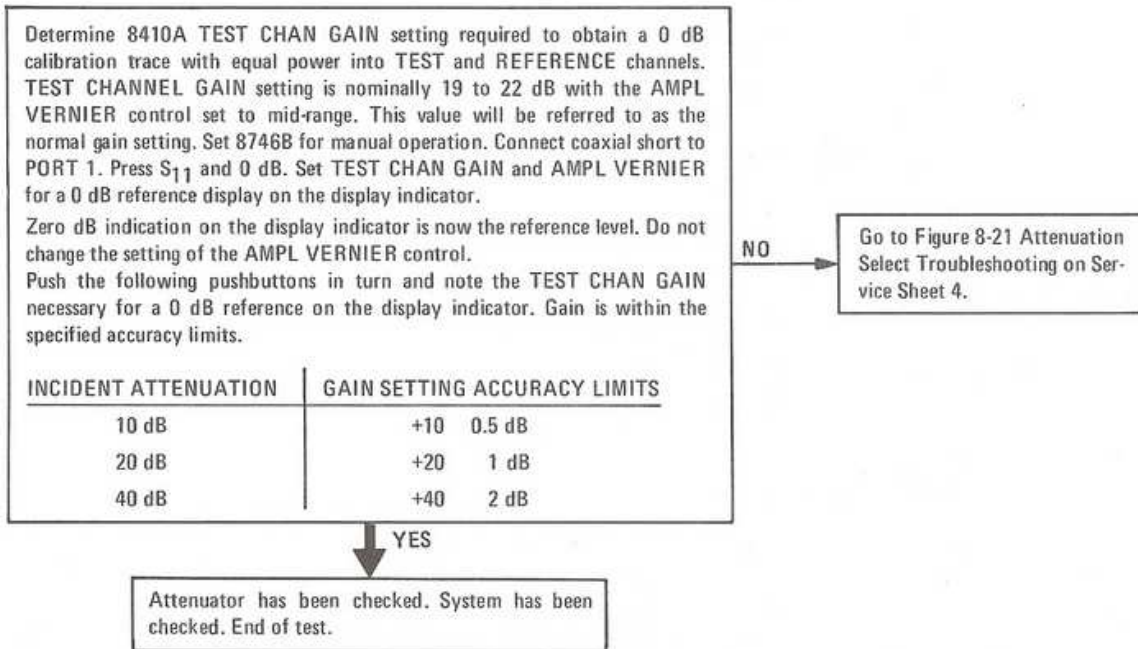

Figure 8-22. A6 (Attenuator) Assembly Troubleshooting

Table 8-8. Attenuator Driver Truth Table

ATTENUATION	10 dB	20 dB	40 dB
0 dB	0	0	0
10 dB	X	0	0
20 dB	0	X	0
30 dB	X	X	0
40 dB	0	0	X
50 dB	X	0	X
60 dB	0	X	X
70 dB	X	X	X

0 = Attenuator Section Not Used.
X = Attenuator Section Used.

Table 8-9. Attenuator Driver Voltage Table

ATTENUATION	A3TP8	A3TP9	A3TP10	A3TP11	A3TP12	A3TP13
0 dB	$\leq +2V$	$\leq -23.3V^*$	$\leq +2V$	$\leq -23.3V^*$	$\leq +2V$	$\leq -23.3V^*$
10 dB	$\geq +6V$	$\geq +23.3V^*$	$\leq +2V$	$\leq -23.3V^*$	$\leq +2V$	$\leq -23.3V^*$
20 dB	$\leq +2V$	$\leq -23.3V^*$	$\geq +6V$	$\geq +23.3V^*$	$\leq +2V$	$\leq -23.2V^*$
30 dB	$\geq +6V$	$\geq +23.3V^*$	$\geq +6V$	$\geq +23.3V^*$	$\leq +2V$	$\leq -23.3V^*$
40 dB	$\leq +2V$	$\leq -23.3V^*$	$\leq +2V$	$\leq -23.3V^*$	$\geq +6V$	$\geq +23.3V^*$
50 dB	$\geq +6V$	$\geq +23.3V^*$	$\leq +2V$	$\leq -23.2V^*$	$\geq +6V$	$\geq +23.3V^*$
60 dB	$\leq +2V$	$\leq -23.3V^*$	$\geq +6V$	$\geq +23.3V^*$	$\geq +6V$	$\geq +23.3V^*$
70 dB	$\geq +6V$	$\geq +23.3V^*$	$\geq +6V$	$\geq +23.3V^*$	$\geq +6V$	$\geq +23.3V^*$

*A more accurate check consists in measuring the voltage drop across the saturated output transistor. This voltage should not exceed 1.2 volts.

HP 8746b 0.5-12.4 GHz S-parameter test-set

Model 8746B

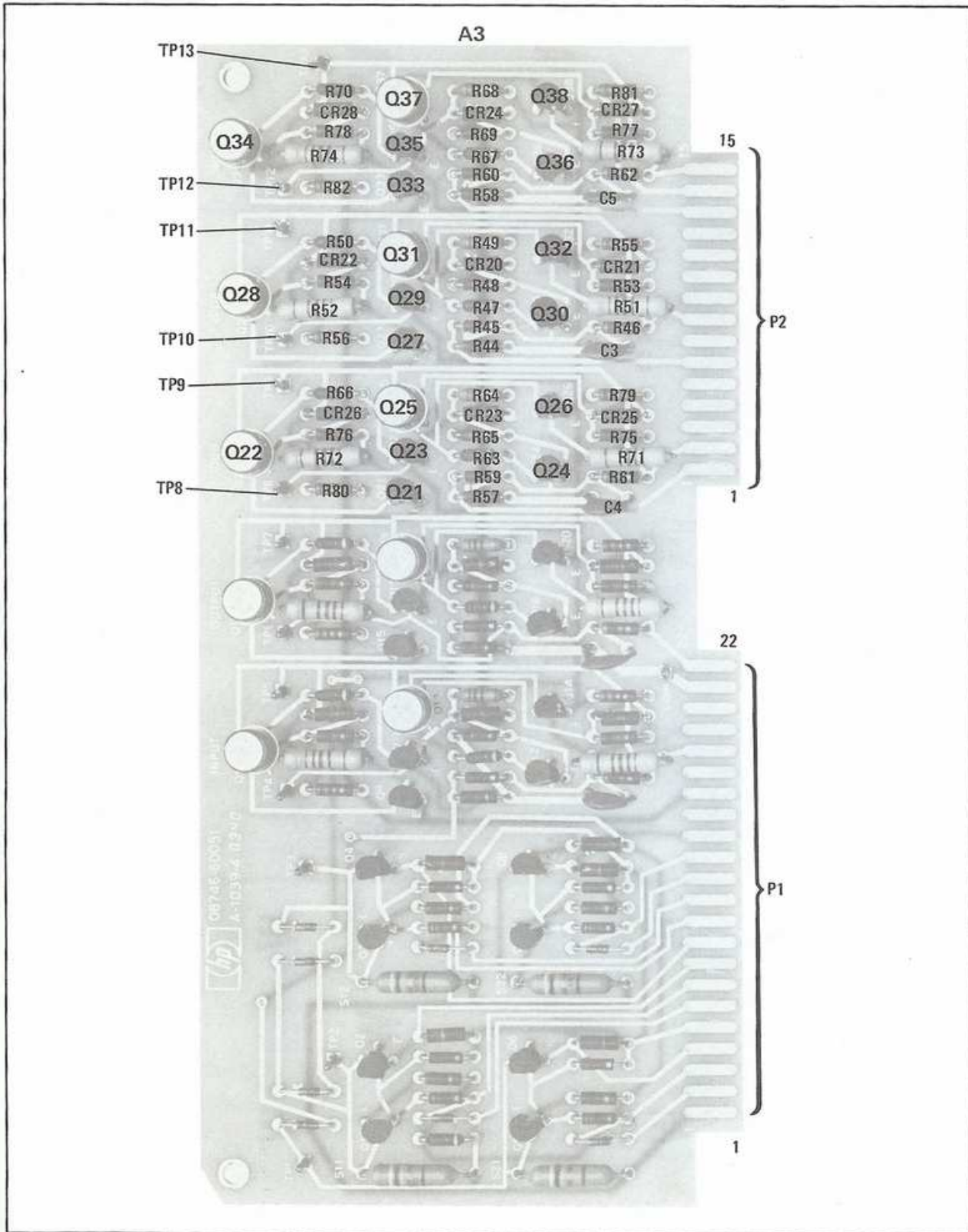
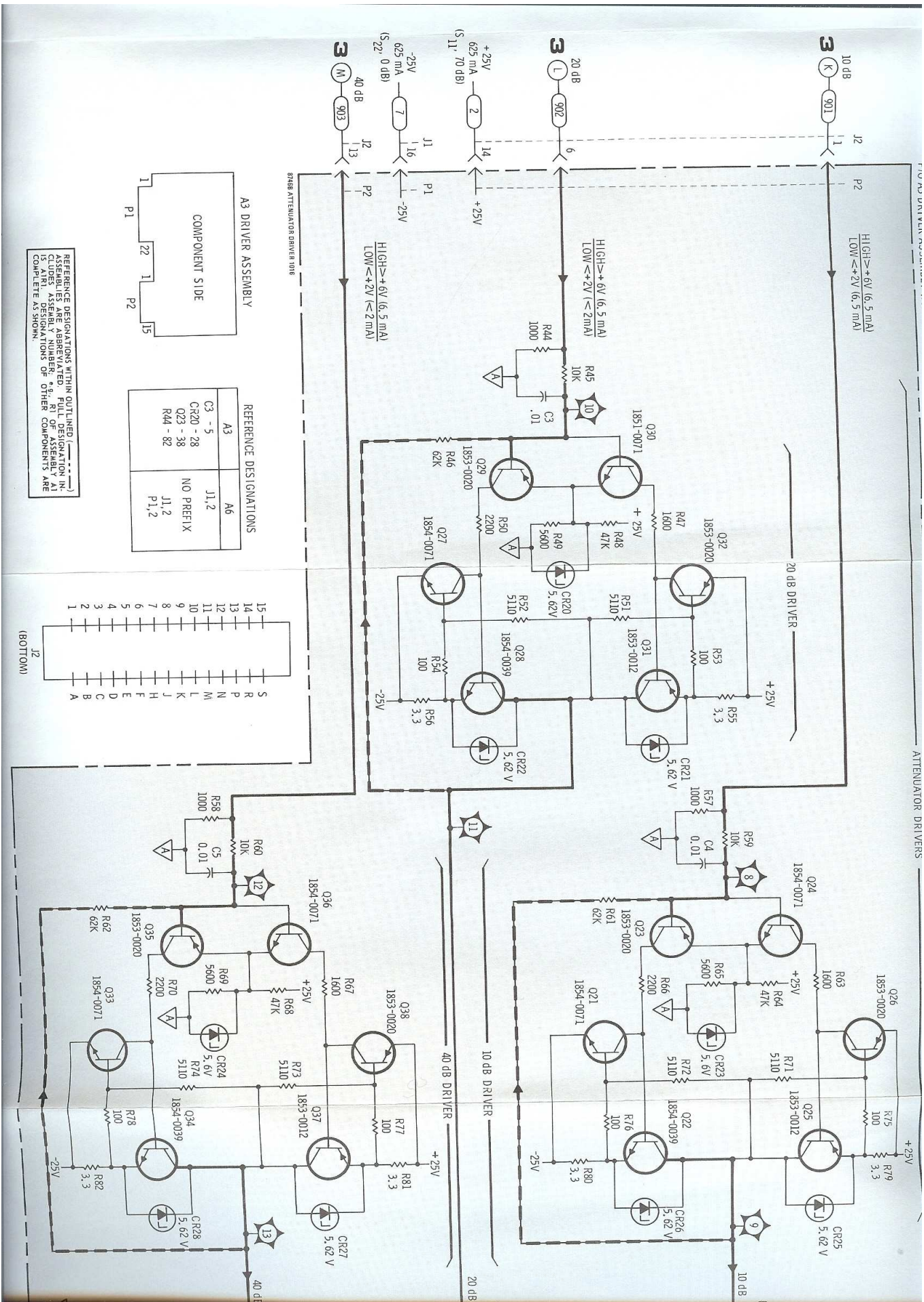

Figure 8-23. A3 Driver Assembly, Parts Location

SERVICE SHEET 4

HP 8746b 0.5-12.4 GHz S-parameter test-set



HP 8746b 0.5-12.4 GHz S-parameter test-set

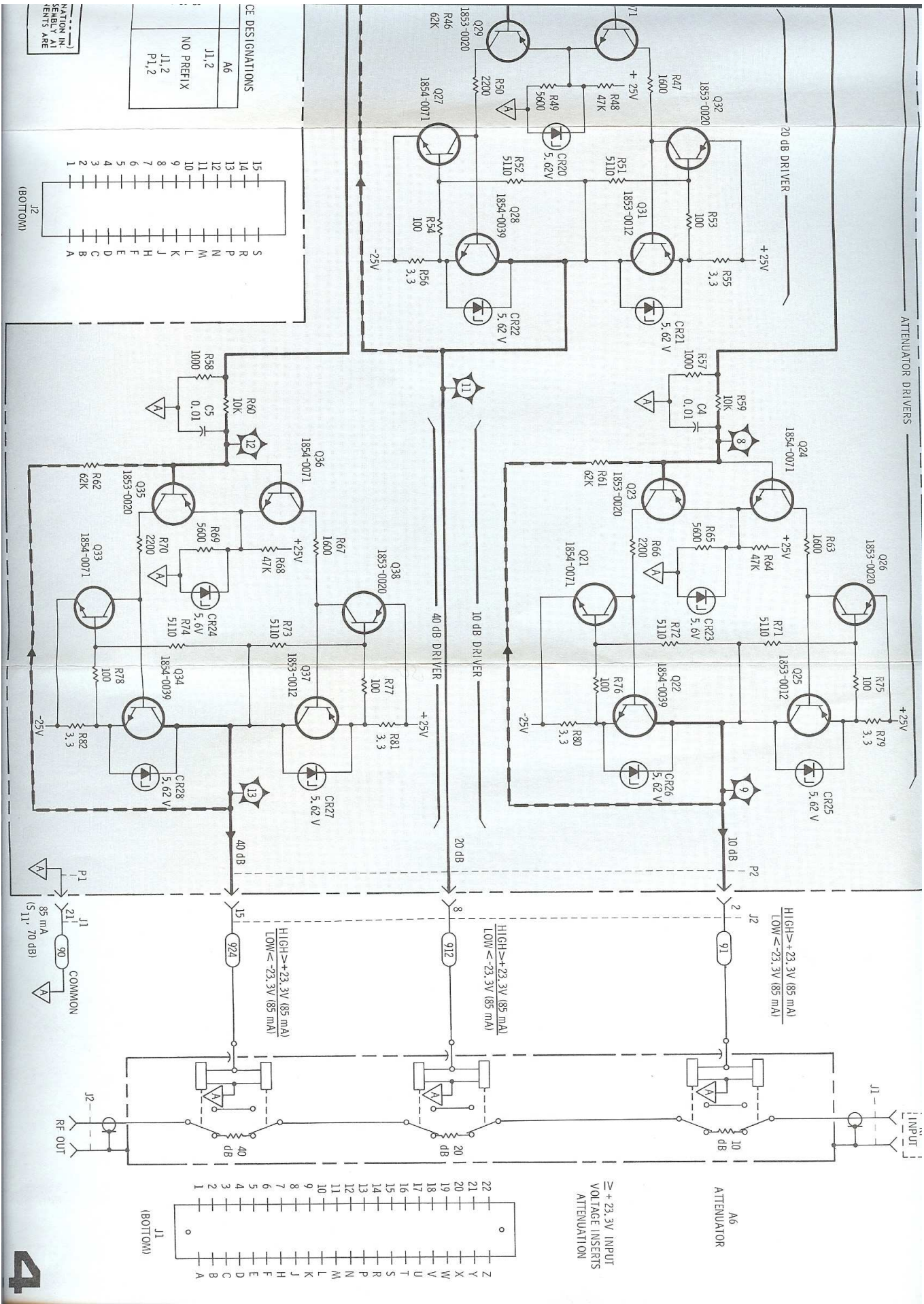

SERVICE SHEET 5

REMOTE CONTROL AND SWITCHING CONVERTER CIRCUIT DESCRIPTION
(Short pin 17 of J6 to pin 18 or 36 for remote operation)

Closing a remote control closure lowers the voltage on the base of the corresponding remote control circuit transistor, reducing the current flow through this transistor. When the current through the control transistor drops, the output goes high (positive). Positive inputs to the switching converter are decoded in the converter. The switching converter outputs then latch the appropriate latching circuit by delivering a low voltage to that one latching circuit while holding all of the other circuits in that selection group at a high voltage.

Refer to the appropriate truth table and voltages at the test points on the schematic opposite for a particular selection.

REMOTE CONTROL LOGIC CIRCUITRY

Since an understanding of the MANUAL pushbutton mode is necessary before going to REMOTE mode, refer to S-Parameter Latching and Driver Circuit Description on Service Sheet 2 first, if unfamiliar with manual mode of operation.

REMOTE MODE

Since all remote control circuits (s-parameter and attenuation) work similarly, the action will be explained only for the S₁₁ parameter selection.

Remote control circuits are energized by shorting pin 17 of the REMOTE INPUT (J6) jack to either pin 18 or 36. S-Parameter and attenuation selection may be effected remotely by opening or closing the remote selection contact closures as shown in Table 8-10.

Table 8-10. Remote Control Parameter and Attenuation Select Truth Table

S-PARAMETER		ATTENUATION	"10 dB bit"	"20 dB bit"	"40 dB bit"
Bits	"1"				
S ₁₁	H	0 dB	H	H	H
S ₁₂	L	10 dB	L	H	H
S ₂₁	H	20 dB	H	L	H
S ₂₂	L	30 dB	L	L	H
		40 dB	H	H	L
		50 dB	L	H	L
		60 dB	H	L	L
		70 dB	L	L	L

H = high voltage (no closure)
 = ≥ +3V input to Switching Converter
 = 0 V output of Converter (input to associated latch circuit)
 = ≥ +5V input to associated driver(s)
 = ≥ +23.3V output from driver(s)

L = low voltage (contact closure)
 = 0V input to Switching Converter
 = ≥ +3V output of Converter (input to associated latch circuit)
 = ≤ +2V input to associated driver(s)
 = ≤ -23.3V output from driver(s).

NOTE: Check operation of all pushbutton circuitry.
 Manual Select S-Parameter Troubleshooting on Service Sheet 2
 Attenuation Select Troubleshooting on Service Sheet 3

From Preliminary Troubleshooting, Figure 8-2

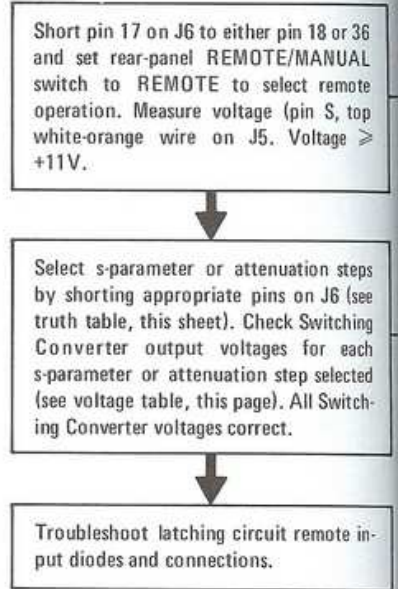

Figure 8-25. Remote Control Troubleshooting

Short pin 17 of REMOTE INPUT jack to either pin 18 or 36 for remote operation. Measure voltage to test points on schematic opposite to REMOTE INPUT jack. All of these voltages should be within power supply voltages.

CONDITIONS: Pin 18 or 36 shorted to:	BUFFER	
	PARAMETER	TP
No pins	S ₁₁	≤ +2V
pin 6	S ₁₂	≥ +3V
pin 24	S ₂₁	≤ +2V
pins 6 & 24	S ₂₂	≥ +3V

HP 8746b 0.5-12.4 GHz S-parameter test-set

NOTE: Check operation of all pushbutton circuits in manual operation first. See Manual Select S-Parameter Troubleshooting on Service Sheet 2 and Manual Attenuation Select Troubleshooting on Service Sheet 4.

From Preliminary Troubleshooting, Figure 8-2.

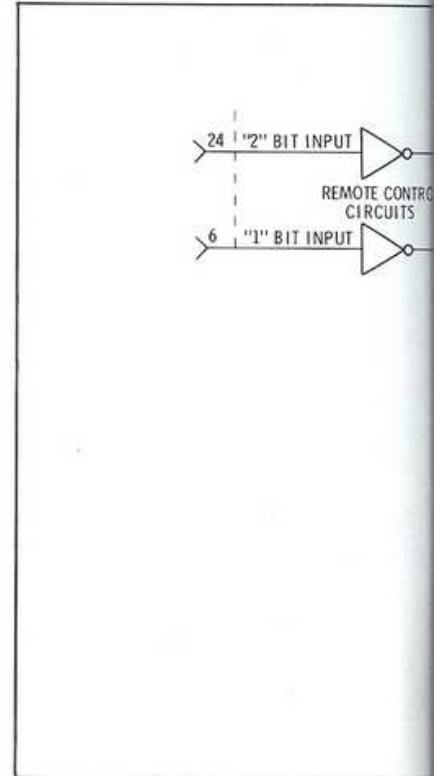
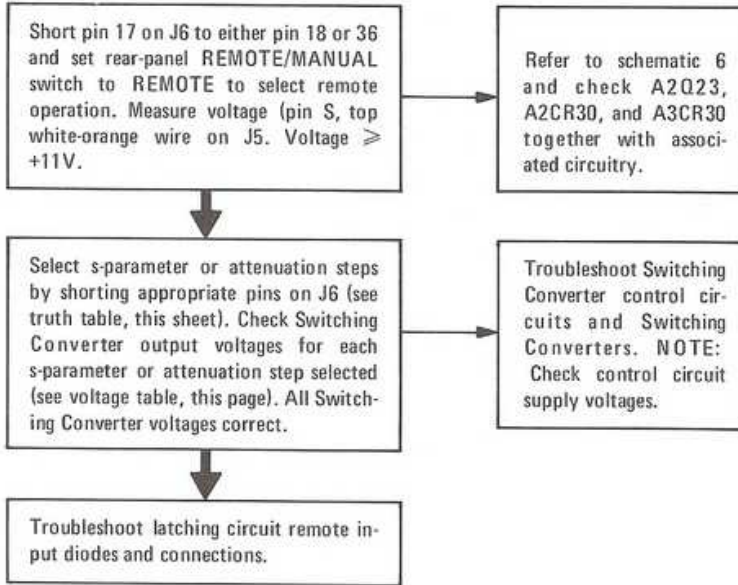

Figure 8-25. Remote Control Troubleshooting

Table 8-11. Remote Control Voltage Table

Short pin 17 of REMOTE INPUT jack to pin 18 or 36 and MANUAL/REMOTE switch to REMOTE for remote operation. Measure voltage to common (any white-black wire) from pins 6, 15, 16, 24, and 33 of REMOTE INPUT jack. All of these voltages should be $\geq +5V$. If not, trouble is in associated control circuit or power supply voltages.								CONDITION: Pin 18 or 36 shorted to:
CONDITIONS: Pin 18 or 36 shorted to:	BUFFER ASSEMBLY A2 REMOTE OPERATION S-PARAMETER VOLTAGE TABLE							
	PARAMETER	TP 1	TP 2	U1 PIN 1	U1 PIN 2	U1 PIN 3	U1 PIN 4	
No pins	S_{11}	$\leq +2V$	$\leq +2V$	$\geq +9V$	$\geq +9V$	$\geq +9V$	$\leq +2V$	No pins
pin 6	S_{12}	$\geq +3V$	$\leq +2V$	$\geq +9V$	$\geq +9V$	$\leq +2V$	$\geq +9V$	pin 15
pin 24	S_{21}	$\leq +2V$	$\geq +3V$	$\geq +9V$	$\leq +2V$	$\geq +9V$	$\geq +9V$	pin 33
pins 6 & 24	S_{22}	$\geq +3V$	$\geq +3V$	$\leq +2V$	$\geq +9V$	$\geq +9V$	$\geq +9V$	pins 15, 33
								pin 16
								pins 15, 16
								pins 16, 33
								pins 15, 16,
								NOT

Service

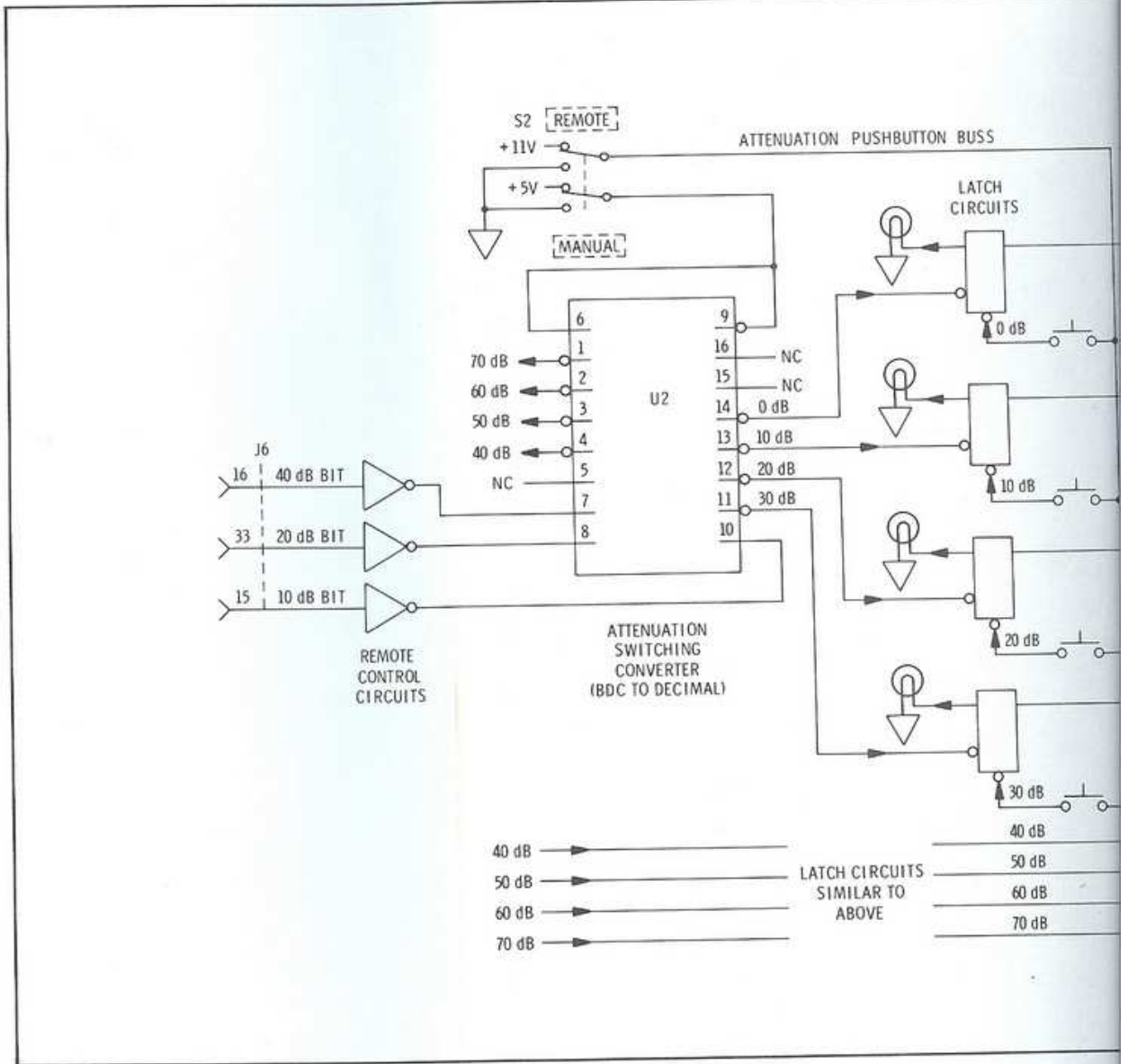

Figure 8-27. Remote Attenuator, Block Diagram

HP 8746b 0.5-12.4 GHz S-parameter test-set

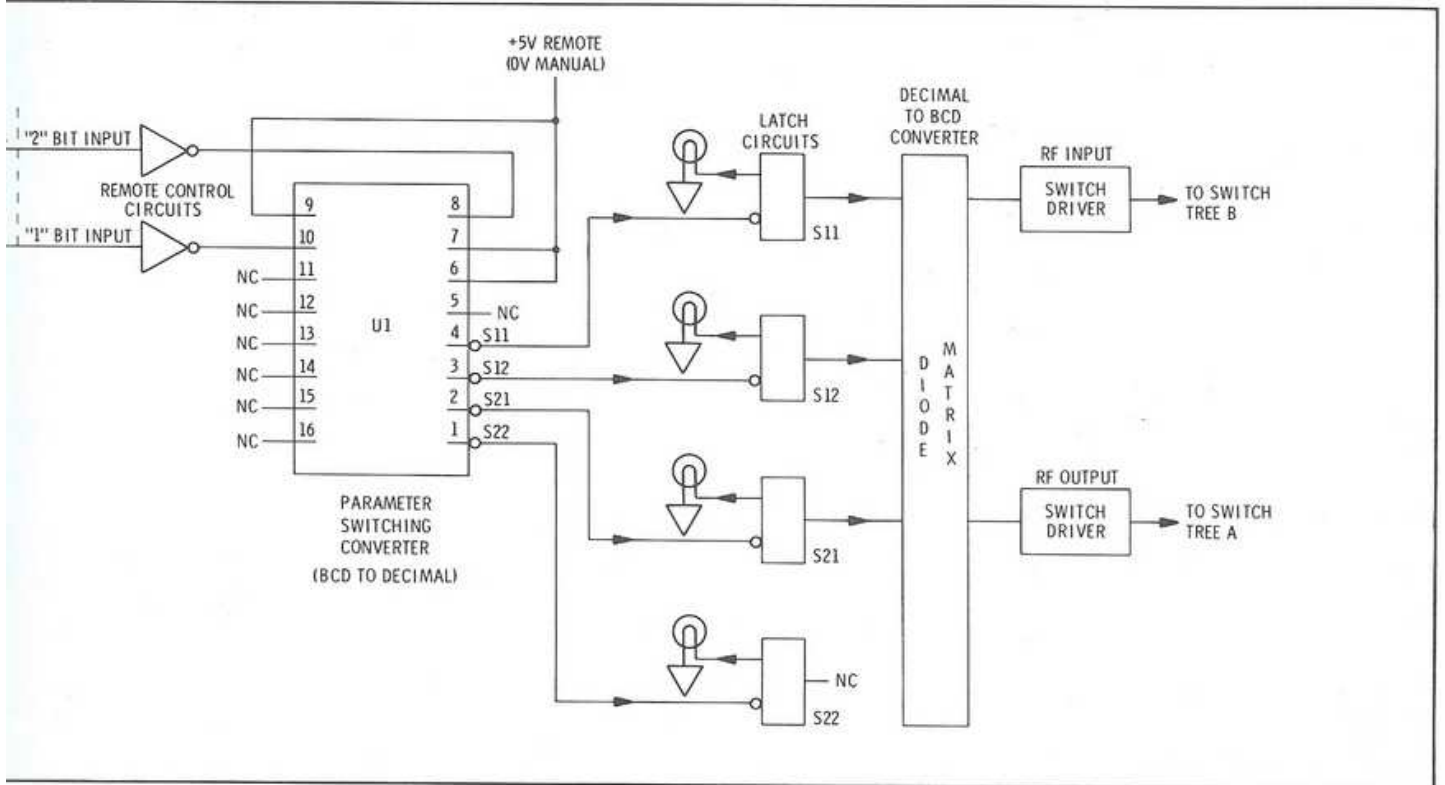

Figure 8-26. Remote S-Parameter, Block Diagram

8-11. Remote Control Voltage Table

re- RE- -or	CONDITIONS: Pin 18 or 36 shorted to.	BUFFER ASSEMBLY A2 REMOTE OPERATION ATTENUATION VOLTAGE TABLE											
		ATTENUATION	TP 3	TP 4	TP 5	U2 PIN 1	U2 PIN 2	U2 PIN 3	U2 PIN 4	U2 PIN 11	U2 PIN 12	U2 PIN 13	U2 PIN 14
	No pins	0 dB	≤ +1V	≤ +1V	≤ +1V	≥ +9V	≥ +9V	≥ +9V	≥ +9V	≥ +9V	≥ +9V	≥ +9V	≤ +2V
	pin 15	10 dB	≥ +3V	≤ +1V	≤ +1V	≥ +9V	≥ +9V	≥ +9V	≥ +9V	≥ +9V	≥ +9V	≤ +2V	≥ +9V
	pin 33	20 dB	≤ +1V	≥ +3V	≤ +1V	≥ +9V	≥ +9V	≥ +9V	≥ +9V	≥ +9V	≤ +2V	≥ +9V	≥ +9V
IN 4	pins 15, 33	30 dB	≥ +3V	≥ +3V	≤ +1V	≥ +9V	≥ +9V	≥ +9V	≥ +9V	≤ +2V	≥ +9V	≥ +9V	≥ +9V
+2V	pin 16	40 dB	≤ +1V	≤ +1V	≥ +3V	≥ +9V	≥ +9V	≥ +9V	≤ +2V	≥ +9V	≥ +9V	≥ +9V	≥ +9V
+9V	pins 15, 16	50 dB	≥ +3V	≤ +1V	≥ +3V	≥ +9V	≥ +9V	≤ +2V	≥ +9V	≥ +9V	≥ +9V	≥ +9V	≥ +9V
+9V	pins 16, 33	60 dB	≤ +1V	≥ +3V	≥ +3V	≥ +9V	≤ +2V	≥ +9V	≥ +9V	≥ +9V	≥ +9V	≥ +9V	≥ +9V
+9V	pins 15, 16, 33	70 dB	≥ +3V	≥ +3V	≥ +3V	≤ +2V	≥ +9V	≥ +9V	≥ +9V	≥ +9V	≥ +9V	≥ +9V	≥ +9V

NOTE: All of these voltages are measured with respect to common (any white-black wire), NOT GROUND.

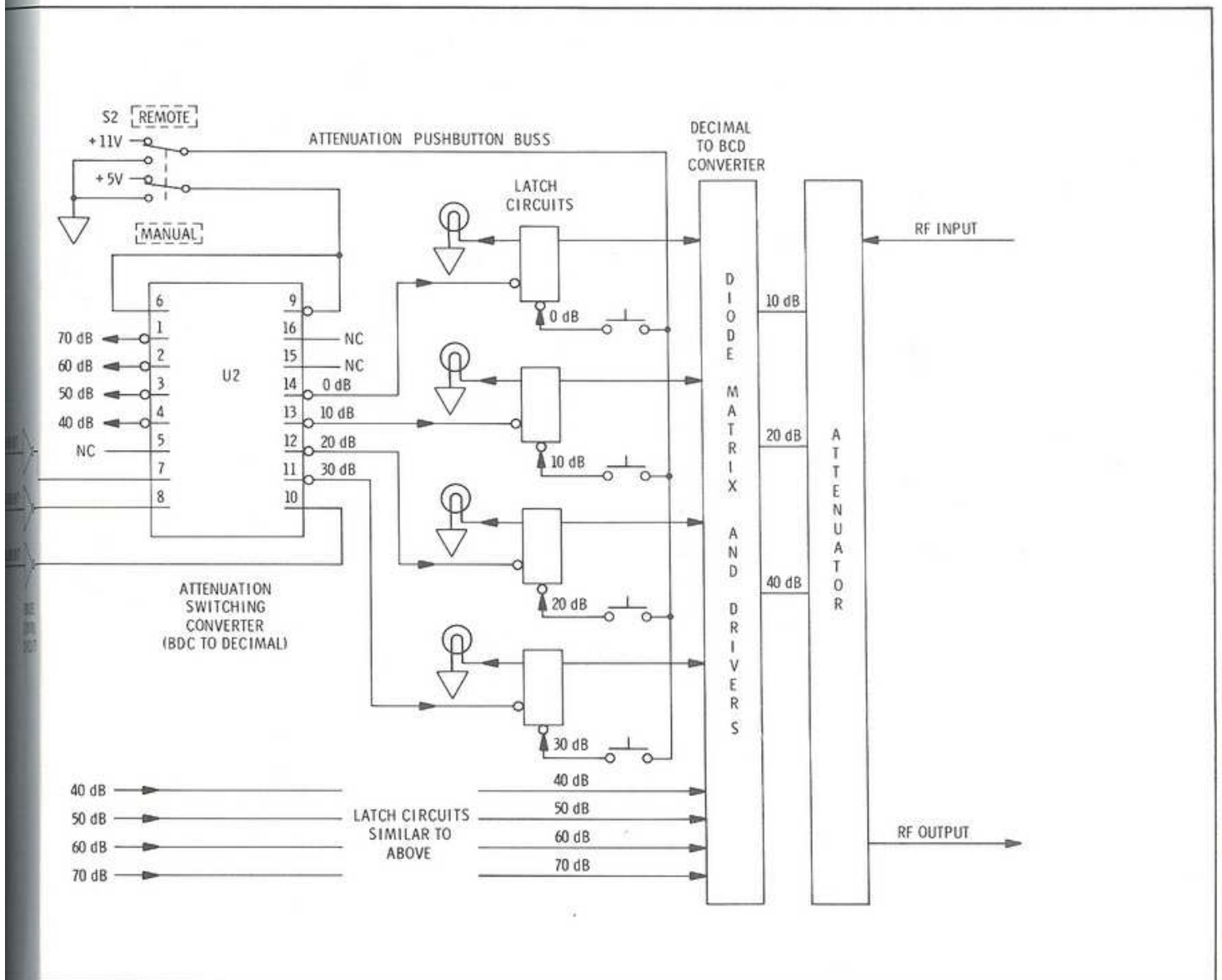

Figure 8-27. Remote Attenuator, Block Diagram

HP 8746b 0.5-12.4 GHz S-parameter test-set

Model 8746B

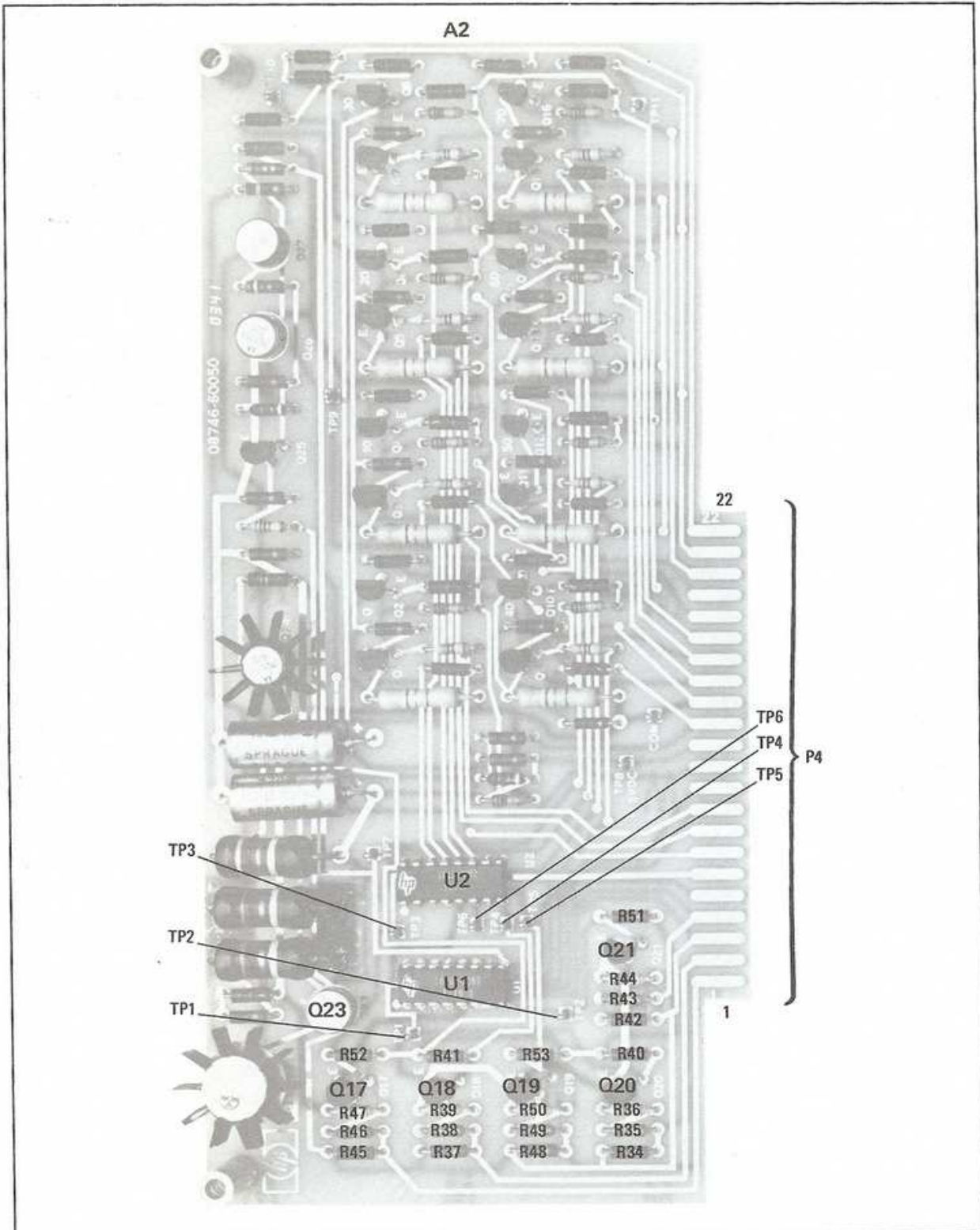

Figure 8-28. A2 Buffer Assembly, Parts Location

SERVICE SHEET 5

HP 8746b 0.5-12.4 GHz S-parameter test-set

NOTES:

1. NUMERATOR : REMOTE OPERATION ENABLED
DENOMINATOR : REMOTE OPERATION DISABLED
2. BOLD NUMBERS INDICATE SCHEMATIC NUMBERS
3. FOR REMOTE OPERATION PIN 17 OF J6 MUST ALSO BE SHORTED TO PIN 18 OR 36.

S-PARAMETER SELECT TRUTH TABLE

S-PARAMETER	REMOTE CONTACT CLOSURE	PIN 6 "1" BIT	PIN 24 "2" BIT
S ₁₁	OPEN	OPEN	OPEN
S ₁₂	SHORTED	SHORTED	OPEN
S ₂₁	OPEN	OPEN	SHORTED
S ₂₂	SHORTED	SHORTED	SHORTED

ATTENUATION SELECT TRUTH TABLE

ATTENUATION	PIN 15 "10 dB"	PIN 33 "20 dB"	PIN 16 "40 dB"
0 dB	OPEN	OPEN	OPEN
10 dB	SHORTED	OPEN	OPEN
20 dB	OPEN	SHORTED	OPEN
30 dB	OPEN	OPEN	SHORTED
40 dB	SHORTED	OPEN	SHORTED
50 dB	OPEN	SHORTED	SHORTED
60 dB	SHORTED	SHORTED	SHORTED
70 dB	SHORTED	SHORTED	SHORTED

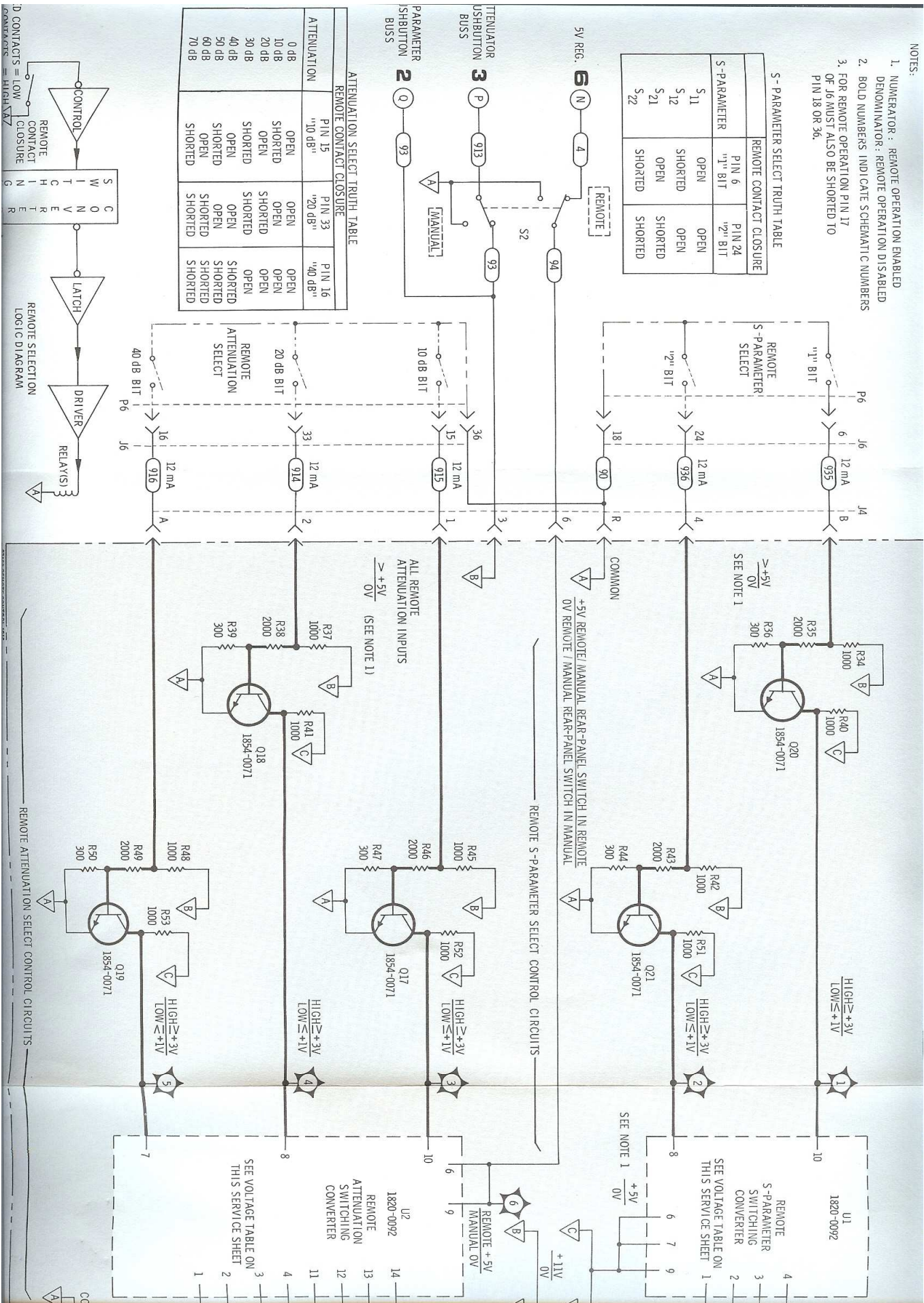

HP 8746b 0.5-12.4 GHz S-parameter test-set

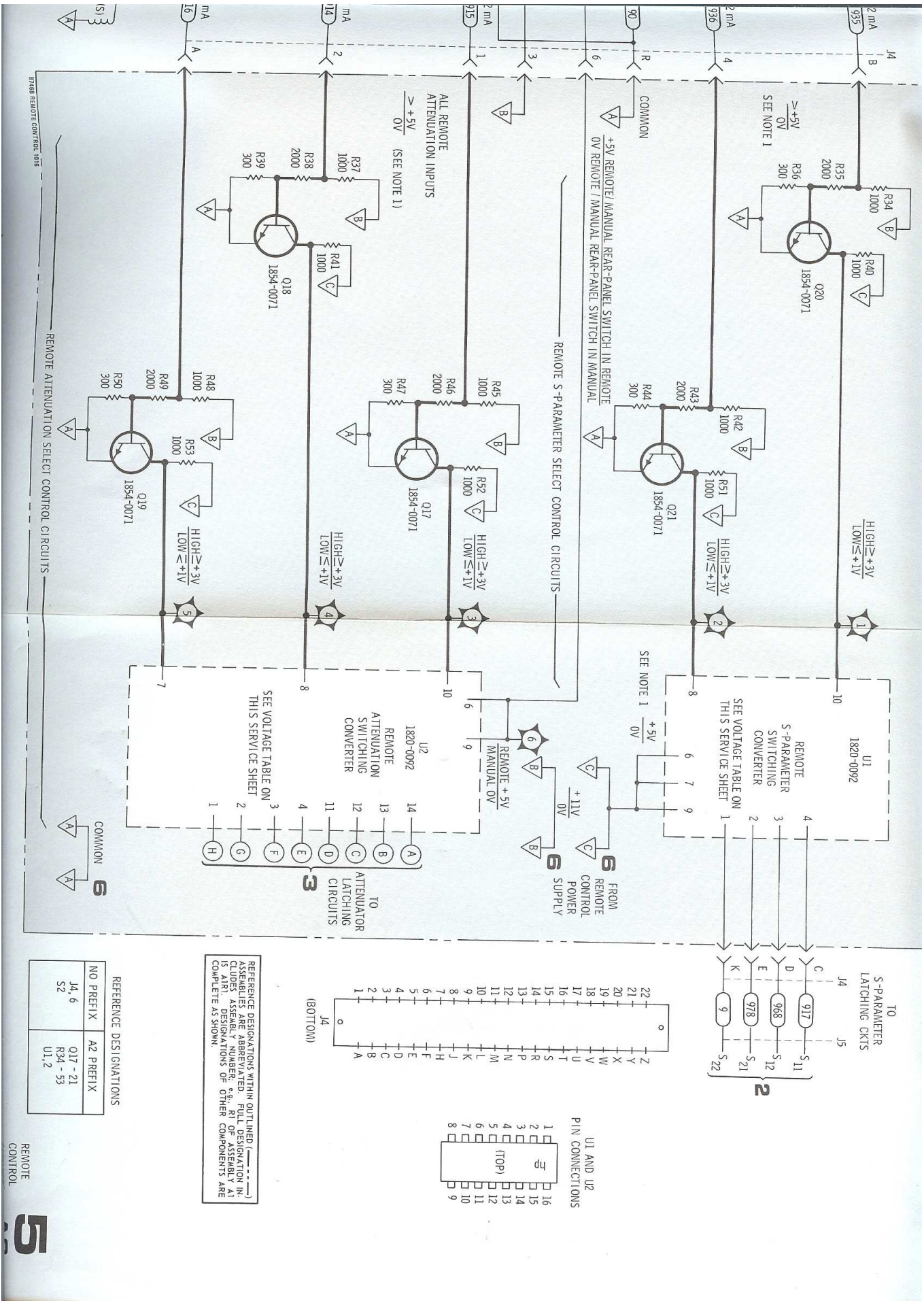

SERVICE SHEET 6

POWER SUPPLY CIRCUITRY

Two power supplies (+25 volt and -25 volt), connected back to back, constitute the 8746B main power supplies. These power supplies are fed by a conventional input circuit with 115 volt or 230 volt input voltage selection. A switch, A10S1, connects the two primaries of transformer T1 in parallel for 115 volts or in series for 230 volts. The transformer secondary voltage is applied to four rectifiers, A1CR1 through A1CR4, connected in a bridge configuration. The bridge rectifier output is fed to series regulators A1Q8 and A1Q4. Transistor A1Q6 samples the +25 volt supply's output across voltage divider A1R13 through A1R15. Diode A1CR5 holds transistor A1Q6's emitter voltage constant. If the supply's output voltage increases, A1Q6's conduction through A1R3 increases. The base voltage on A1Q7 decreases, decreasing the base voltage on A1Q8, which decreases the output voltage.

Transistor A1Q5, which is normally cutoff, is an over-current control. If the current through A1R11 exceeds about 2 amperes (1 ampere on -25 volt supply), A1Q5 will conduct. Collector current through A1R3 will decrease the base voltage on A1Q7, shutting down the series regulator A1Q8.

The -25 volt supply operates in a similar manner, except it starts shutting down at about 1 ampere current.

REMOTE CONTROL POWER SUPPLY CIRCUIT DESCRIPTION

The Remote Control Power Supply circuitry consists of transistors A2Q22 through A2Q27 with associated components. This supply furnishes +11.5 volts to the Switch Panel Assembly A4 in the remote mode and zero volts in the manual mode. In addition, this supply furnishes +5 volts to the S-Parameter and Attenuation Switching Converters U1 and U2 in the remote mode and zero volts in the manual mode.

The input to the Remote Control Circuitry is +25 volts from the instrument power supply. Transistor A2Q22 is a series regulator whose output is +11.5 volts. This series regulator feeds a second series regulator A2Q24 which, in turn, provides +5 volts to A2Q27. These regulators have their bases held at fixed voltages by zener diodes A2CR30 and A2CR31. The series regulators act as emitter-followers with the output voltage being held to the zener diode voltage minus the emitter-base voltage drop of the transistors.

Transistor A2Q23 is a switch, controlled by a remote contact closure, J6 Pin 17, shorted to pins 18 or 36 (circuit common). Shorting pin 17 to common turns on A2Q23. The collector of A2Q23 goes from zero to about +11 volts. This voltage is applied to the s-parameter pushbutton buss, disabling the pushbuttons. If the rear-panel REMOTE/MANUAL switch is in the REMOTE position, the +11 volts is applied to the attenuation pushbutton buss to disable the INCIDENT ATTENUATION pushbuttons. The +11 volts is also applied to the base of A2Q25. Transistor A2Q25 is turned on, which turns A2Q27 on, and A2Q26 off. The collectors go to a voltage of about +5 volts, which is applied to the switching converters.

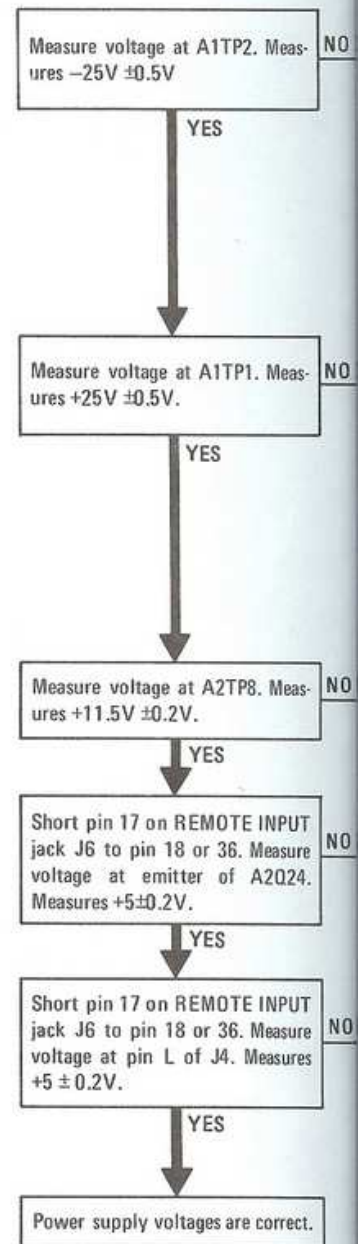

Figure 8-30. Power S

HP 8746b 0.5-12.4 GHz S-parameter test-set

id -25 volt), connected back to back, constitute the ese power supplies are fed by a conventional input t input voltage selection. A switch, A10S1, connects er T1 in parallel for 115 volts or in series for 230 ary voltage is applied to four rectifiers, A1CR1 . bridge configuration. The bridge rectifier output is and A1Q4. Transistor A1Q6 samples the +25 volt iver A1R13 through A1R15. Diode A1CR5 holds e constant. If the supply's output voltage increases, R3 increases. The base voltage on A1Q7 decreases, 1Q8, which decreases the output voltage.

ally cutoff, is an over-current control. If the current 2 amperes (1 ampere on -25 volt supply), A1Q5 will ough A1R3 will decrease the base voltage on A1Q7, r A1Q8.

1 a similar manner, except it starts shutting down at

UPPLY CIRCUIT DESCRIPTION

ply circuitry consists of transistors A2Q22 through ents. This supply furnishes +11.5 volts to the Switch ote mode and zero volts in the manual mode. In s +5 volts to the S-Parameter and Attenuation 2 in the remote mode and zero volts in the manual

ol Circuitry is +25 volts from the instrument power series regulator whose output is +11.5 volts. This series regulator A2Q24 which, in turn, provides +5 volts ors have their bases held at fixed voltages by zener The series regulators act as emitter-followers with the e zener diode voltage minus the emitter-base voltage

controlled by a remote contact closure, J6 Pin 17, uit common). Shorting pin 17 to common turns on 3 goes from zero to about +11 volts. This voltage is ashbutton buss, disabling the pushbuttons. If the switch is in the REMOTE position, the +11 volts is pushbutton buss to disable the INCIDENT The +11 volts is also applied to the base of A2Q25. n, which turns A2Q27 on, and A2Q26 off. The about +5 volts, which is applied to the switching

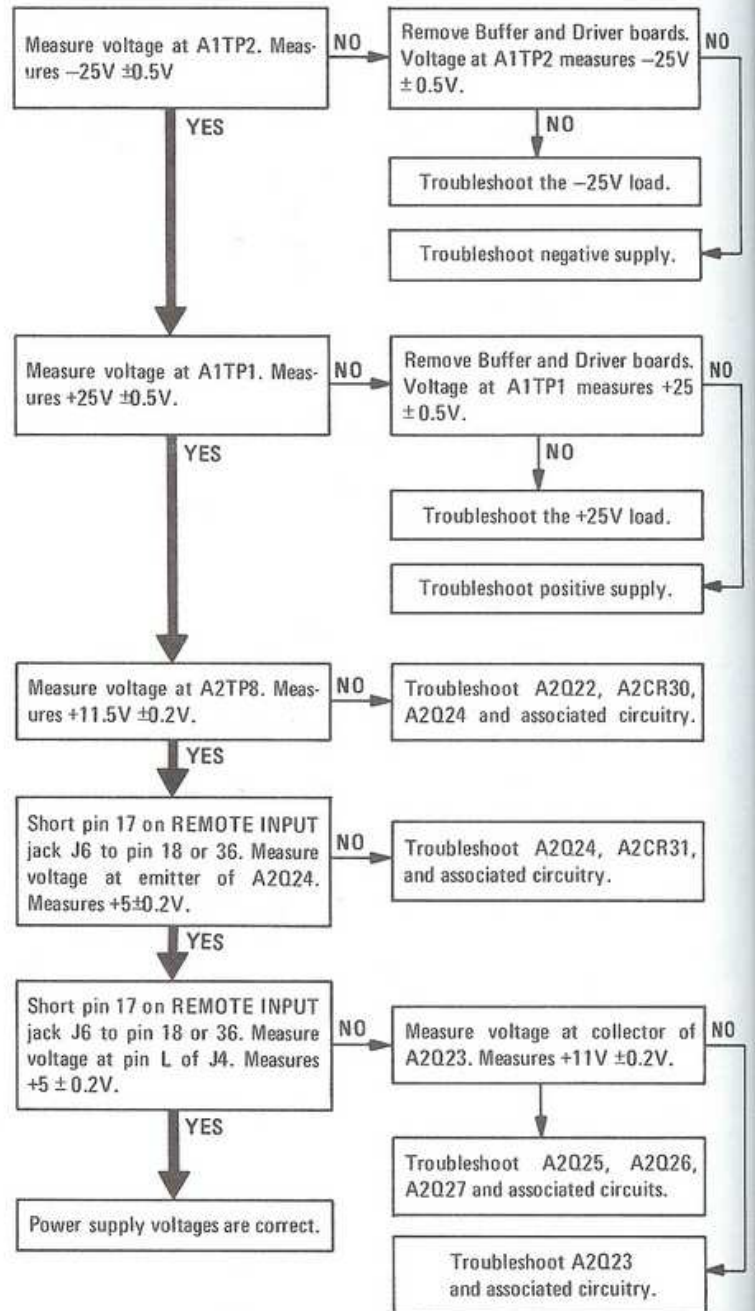

Figure 8-30. Power Supply Troubleshooting

HP 8746b 0.5-12.4 GHz S-parameter test-set

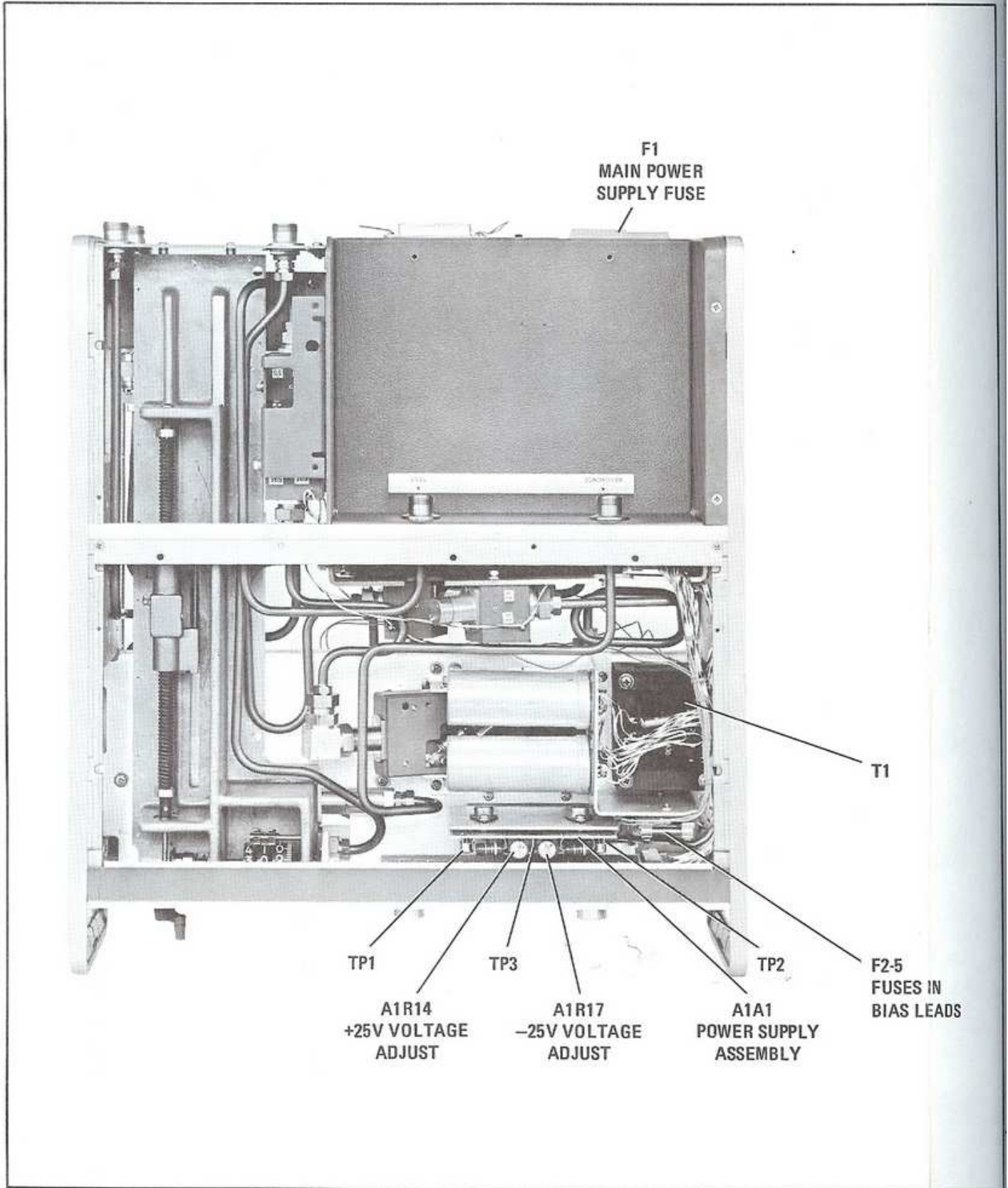

Figure 8-31. Power Supply Adjustments

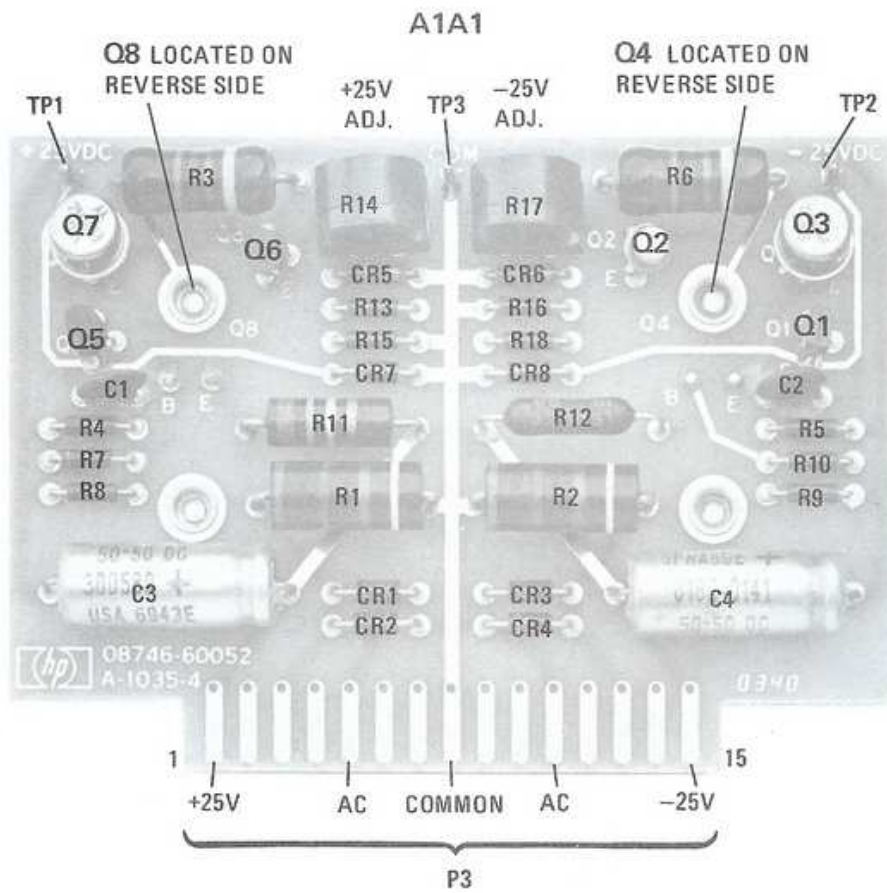

Figure 8-32. A1A1 Power Supply Assembly, Parts Location

HP 8746b 0.5-12.4 GHz S-parameter test-set

Model 8746B

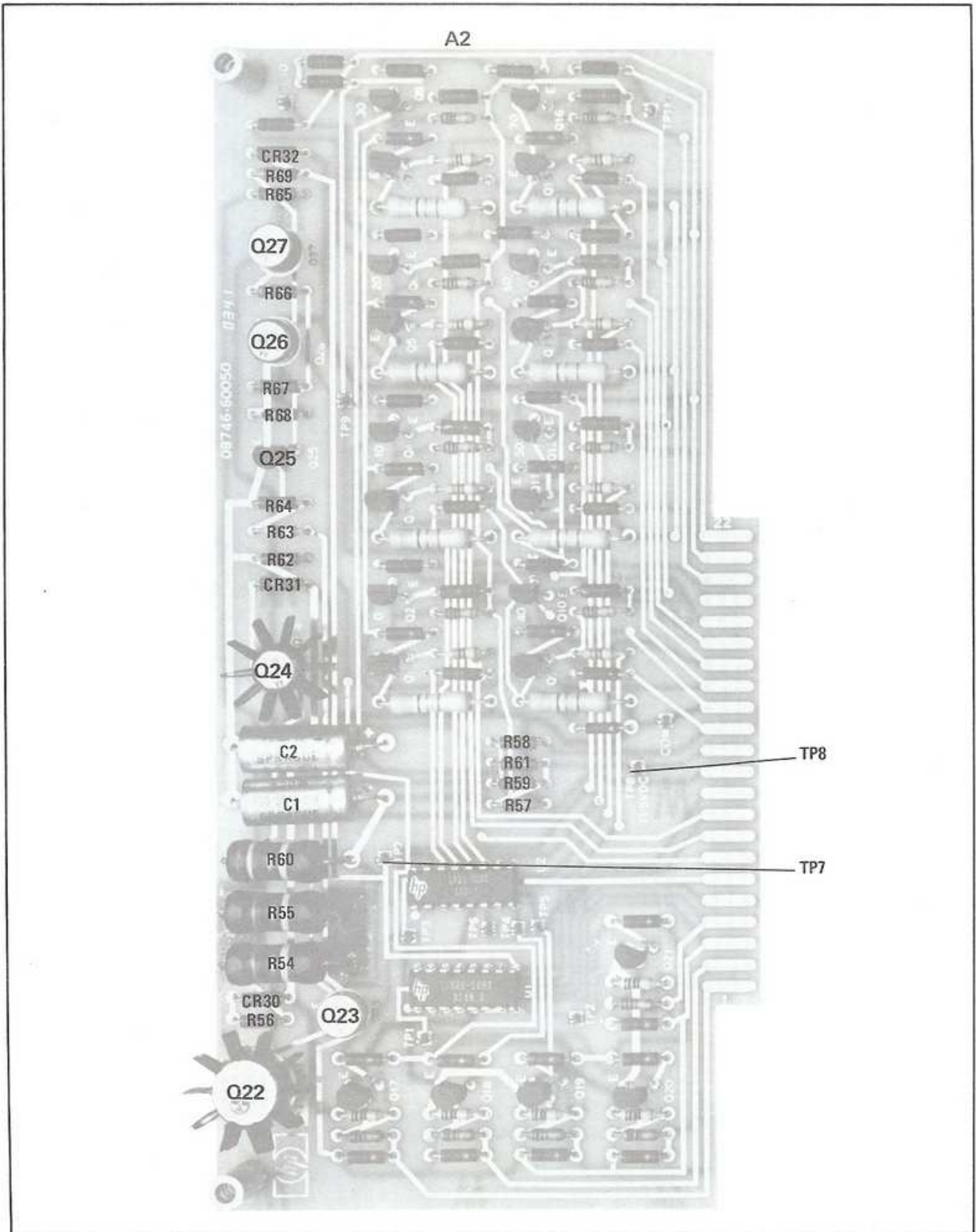

Figure 8-33. A2 Buffer Assembly, Parts Location

HP 8746b 0.5-12.4 GHz S-parameter test-set

REFERENCE DESIGNATIONS

A1 ASSY	A2 ASSY	A9 ASSY	NO PREFIX
C3, 4	C1 - 4	C1, 2	C1
DS1	CR1 - 8	CR30 - 32	S1
F1	Q1 - 8	Q22 - 27	
J3, 4	R1 - 18	R54 - 69	
R1	S1		
S1	T1		
T1	W12		

1. NUMERATOR = REMOTE OPERATION ENABLED
(I6 PIN IS SHORTED TO COMMON)
DENOMINATOR = REMOTE OPERATION IS DISABLED.
2. INDIVIDUAL CIRCUIT CURRENT DRAINS ARE SHOWN ON EACH SCHEMATIC.

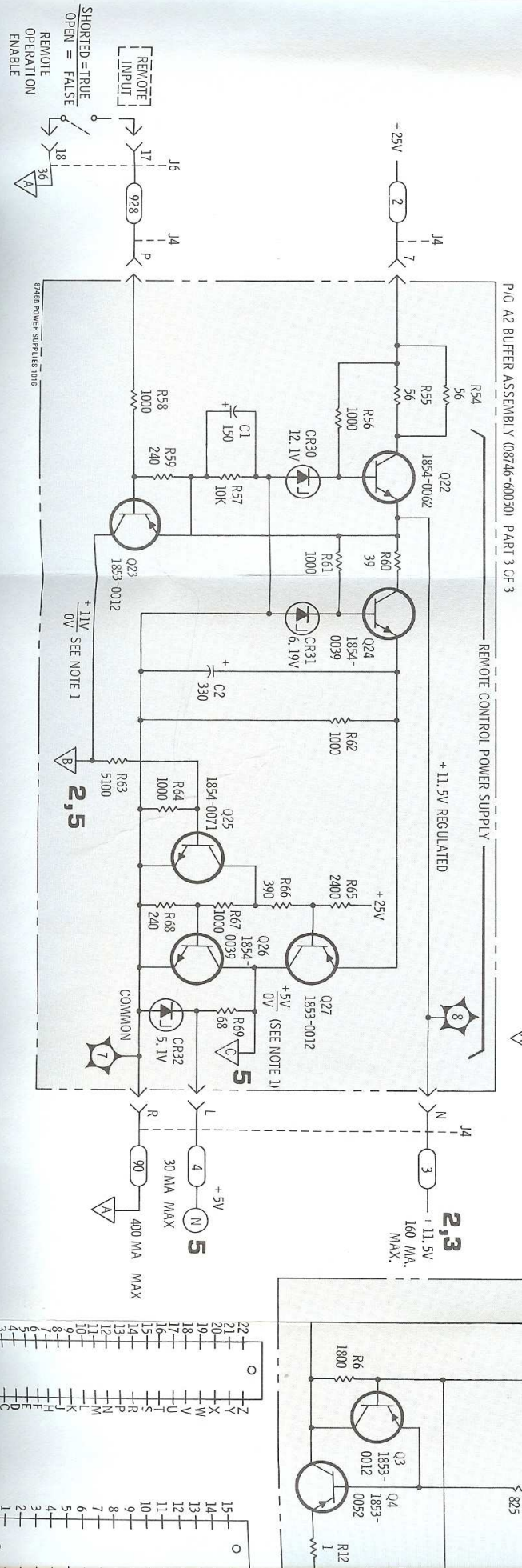
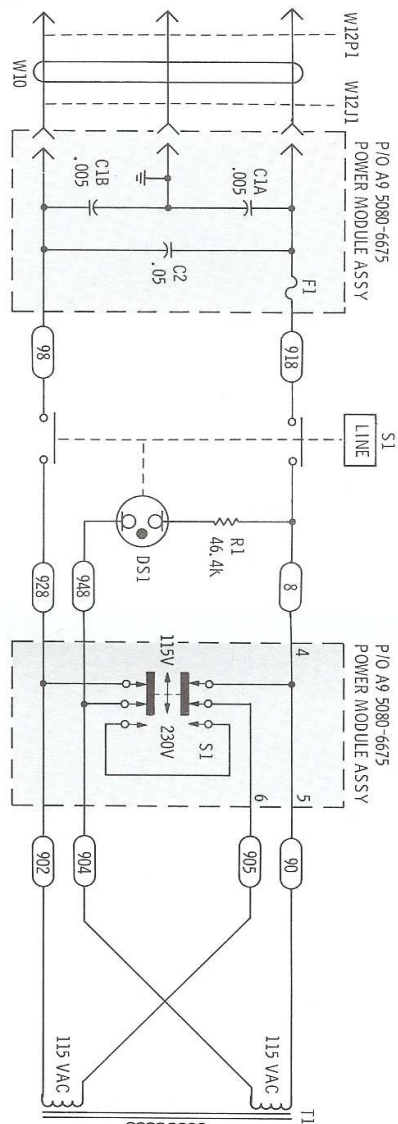

HP 8746b 0.5-12.4 GHz S-parameter test-set

- NUMERATOR = REMOTE OPERATION ENABLED (J6 PIN 17 SHORTED TO COMMON)
- DENOMINATOR = REMOTE OPERATION IS DISABLED.
- INDIVIDUAL CIRCUIT CURRENT DRAINS ARE SHOWN ON EACH SCHEMATIC.

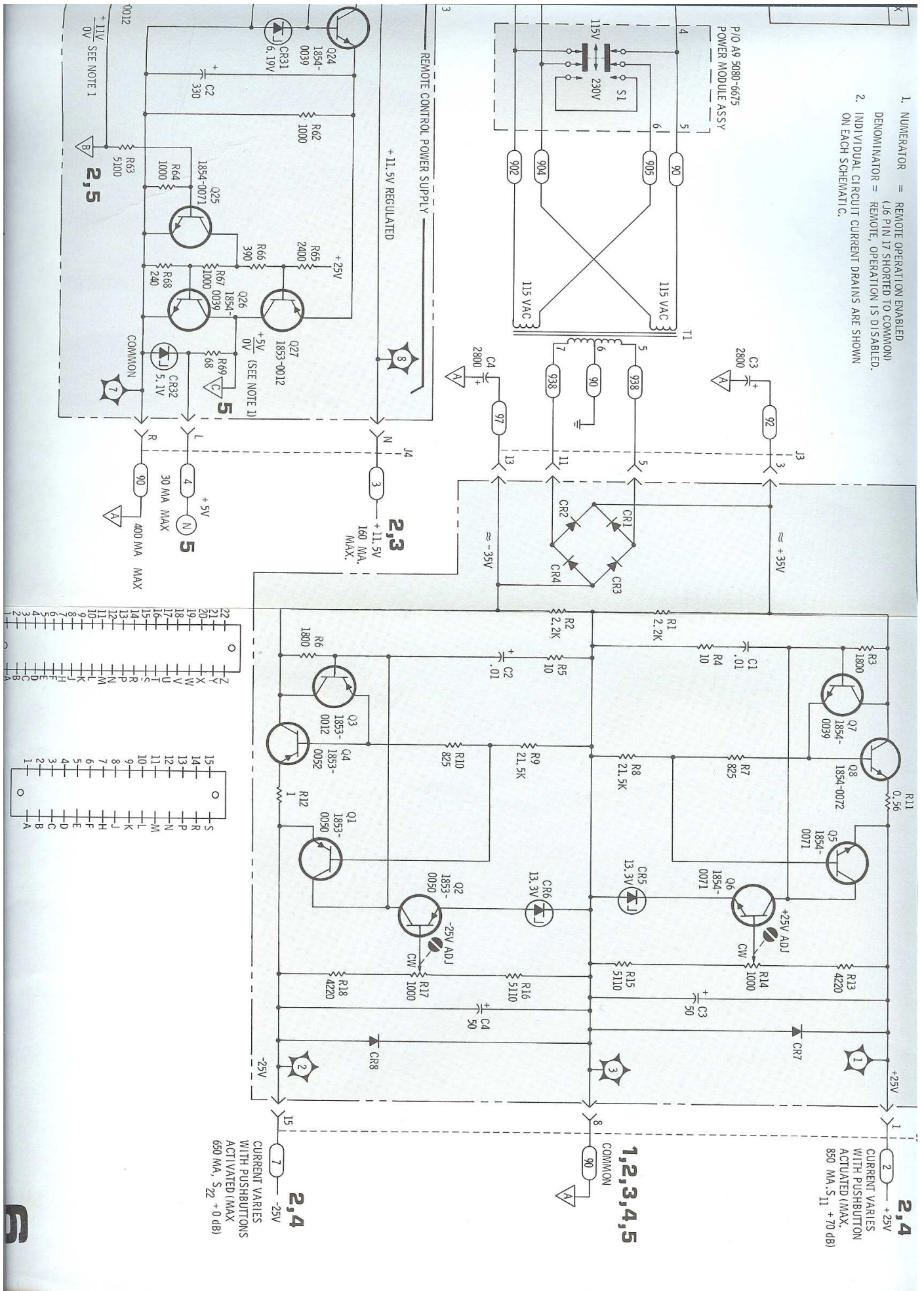

HP 8746b 0.5-12.4 GHz S-parameter test-set

MANUAL CHANGES

MANUAL CHANGES

MANUAL IDENTIFICATION

Model Number: 8746B
 Date Printed: August 1971
 Part Number: 08746-90007

This supplement contains important information for correcting manual errors and for adapting the manual to instruments containing improvements made after the printing of the manual.

To use this supplement:

Make all ERRATA corrections

Make all appropriate serial number related changes indicated in the tables below.

Serial Prefix or Number	Make Manual Changes	Serial Prefix or Number	Make Manual Changes
1116A	1	1420A00503 thru 1420A00520	1, 2, 3, 4
1142A, 1334A	1, 2	1521A00521 thru 1521A00570	1, 2, 3, 4, 5
1420A00456 thru 1420A00502	1, 2, 3	1521A00571 thru 1521A00580	1, 2, 3, 4, 5, 6
		1521A00581 thru 1521A prefix	1, 2, 3, 4, 5, 6, 7
		1636A Prefix	1 - 8
		1817A	1 - 9

► NEW ITEM

ERRATA

Inside front cover:

Insert new information regarding SAFETY, CERTIFICATION, and WARRANTY AND ASSISTANCE immediately inside front cover of manual (new information sheet supplied in this Manual Changes Supplement).

Page 1-1, General Information:

Add the attached Paragraph 1-A preceding Paragraph 1-1:

NOTE

Manual change supplements are revised as often as necessary to keep manuals as current and accurate as possible. Hewlett-Packard recommends that you periodically request the latest edition of this supplement. Free copies are available from all HP offices. When requesting copies quote the manual identification information from your supplement, or the model number and print date from the title page of the manual.

24 MARCH 1980

18 Pages

Printed in U.S.A.



HP 8746b 0.5-12.4 GHz S-parameter test-set

Model 8746B

08746-90007

ERRATA (Con't)

Page 6-10, Table 6-2:

Change the parts list to reflect the changes shown below:

Reference Designation	HP Part Number	Description
A6	08746-60003	STEP ATTENUATOR (NEW).
A6	5080-0314	REBUILT 08746-60003 REQUIRES EXCHANGE.
A7	5080-0310	SWITCH TREE ASSY : MATCHED SET OF THREE (RECOMMENDED REPLACEMENT).
A7S1	5080-0302	RELAY ASSY : (PORT 1) IF REPLACED SEPARATELY MAY DEGRADE PERFORMANCE OF INSTRUMENT.
A7S2	5080-0301	RELAY ASSY : (CENTER) IF REPLACED SEPARATELY, MAY DEGRADE PERFORMANCE OF INSTRUMENT.
A7S3	5080-0303	RELAY ASSY : (PORT 2) IF REPLACED SEPARATELY, MAY DEGRADE PERFORMANCE OF INSTRUMENT.
A8	5080-0310	SWITCH TREE ASSY : MATCHED SET OF THREE (RECOMMENDED REPLACEMENT).
A8S1	5080-0302	RELAY ASSY: (PORT 1) IF REPLACED SEPARATELY, MAY DEGRADE PERFORMANCE OF INSTRUMENT.
A8S2	5080-0301	RELAY ASSY: (CENTER) IF REPLACED SEPARATELY, MAY DEGRADE PERFORMANCE OF INSTRUMENT.
A8S3	5080-0303	RELAY ASSY: (PORT 2) IF REPLACED SEPARATELY, MAY DEGRADE PERFORMANCE OF INSTRUMENT.
DC1	5080-0291	COUPLER PAIR: PORT FOR STANDARD MODEL AND OPTION 001. MATCHED PAIR INCLUDES DC2 (RECOMMENDED REPLACEMENT).
DC1	5080-0307	COUPLER ASSY: PORT FOR STANDARD MODEL AND OPTION 001 (IF REPLACED SEPARATELY MAY DEGRADE PERFORMANCE OF INSTRUMENT).
DC1	5080-0292	COUPLER PAIR: PORT FOR OPTION 002. MATCHED PAIR INCLUDES DC2 (RECOMMENDED REPLACEMENT).
DC1	5080-0309	COUPLER ASSY: PORT FOR OPTION 002. (IF REPLACED SEPARATELY MAY DEGRADE PERFORMANCE OF INSTRUMENT).
DC2	5080-0291	COUPLER PAIR: PORT FOR STANDARD MODEL AND OPTION 001. MATCHED PAIR INCLUDES DC1 (RECOMMENDED REPLACEMENT).
DC2	5080-0307	COUPLER ASSY: PORT FOR STANDARD MODEL AND OPTION 001. (IF REPLACED SEPARATELY MAY DEGRADE PERFORMANCE OF INSTRUMENT).
DC2	5080-0292	COUPLER PAIR: PORT FOR OPTION 002. MATCHED PAIR INCLUDES DC 1 (RECOMMENDED REPLACEMENT).
DC2	5080-0309	COUPLER ASSY: PORT FOR OPTION 002 (IF REPLACED SEPARATELY MAY DEGRADE PERFORMANCE OF INSTRUMENT).
DC 3	5080-0308	COUPLER ASSY: REFERENCE

Page 6-11, Table 6-2:

► Change F1 entry to the following:

F1 2110-0007 CD4 FUSE 1A 250V TIME-DELAY (115V LINE)

F1 2110-0202 CD1 FUSE .5A 250V TIME-DELAY (230V LINE)

Add the following mechanical Parts after J6:

MP1 08746-00026 BOARD RETAINER

MP2 08746-20061 SPACER

MP3 2520-0014 SCREW-MACH 8-32 4-IN-LG RD-HD-SLT STL

Page 6-13, Figure 6-1:

Change Reference Designation 13 to HP Part No. 5000-0737.

ERRATA (Con't)

Page 6-15:

Delete Figure 6-3 and add the following note on this page.

NOTE

All four rear-panel APC-7 type connectors are as shown in Figure 6-4. To repair cables having ferrule 5020-7806, split the ferrule using a hack saw, remove the ferrule, and replace the cable terminator and nut. For panel connectors use terminator 08745-2021 and nut 0590-0035. For internal connectors use terminator 08742-2028 and nut 0590-0035.



Page 6-17/6-18:

Change Reference Designation 4 to read: 4 08745-2021 TERMINATOR: CABLE

Page 8-19, Figure 8-12:

Change assembly descriptions to read as follows:

A7S1 (5080-0302)	A7S2 (5080-0301)	A7S3 (5080-0303)
A8S1 (5080-0302)	A8S2 (5080-0301)	A8S3 (5080-0303)

Change the earth ground symbols on DC1-C4 and DC1-C8 () to chassis ground symbols ().

Page 8-21, Figure 8-16 (Schematic on Service Sheet 2):



Change voltage opposite A3CR16 thru A3CR19 to 56.2V.



Page 8-25, Figure 8-24 (Schematic on Service Sheet 4):

Change voltage opposite A3CR21 and A3CR22, and A3CR25 thru A3CR28 to 56.2V.

Page 8-29, Figure 8-34:

Move Test point A2TP7 to the cathode of A2CR32.

Change the earth ground symbol () to a common return symbol () on the "90" wire that connects to power transformer T1 pin 6 (center tap of secondary winding).

Change the earth ground symbol () at the junction of A9C1A and A9C1B to a chassis ground symbol ().

CHANGE 1

Page 6-3, Table 6-2:

Add A1CR9 1901-0025 DIODE:SILICON 28480 1901-0025.

Change A1R12 to HP Part No. 0811-16666 R:FXD WW 1 OHM 5% 2W.

Add A1R19 0698-3101 R:FXD MET FLM 2.87K OHM 1% 1/2W 28480 0698-3101.

Change A2 to HP Part No. 08746-60054. Description remains the same.

Page 6-5, Table 6-2:

Delete A2R54 and A2R55.

HP 8746b 0.5-12.4 GHz S-parameter test-set

Model 8746B

08746-90007

CHANGE 1 (cont'd)

Page 6-11, Table 6-2:

Add R2HP Part 0819-0022 R:FXD WW 50 OHM 10% 20W.

Page 8-27, Figure 8-29:

Change P/O A2 Buffer Assembly to HP Part No. 08746-60054.

Page 8-28, Service Sheet 6, Figure 8-32:

Substitute attached Figure 8-32 for Figure 8-32 in manual.

Page 8-29, Service Sheet 6, Figure 8-34:

Change P/O A2 Buffer Assembly (08746-60054) Part 3 of 3 as shown in Partial Schematic 8-34 on this change sheet.

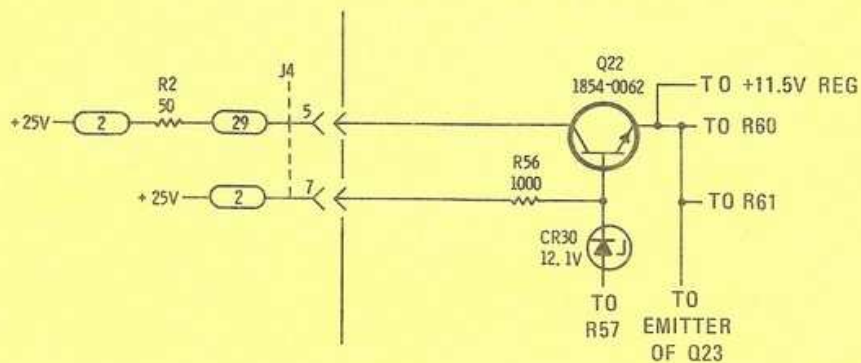

Partial Schematic 8-34. Power Supply (CHANGE 1)

Page 8-29, Service Sheet 6, Figure 8-34, Power Supplies Schematic:

Change A1 Power Supply Assembly (08746-60052) as shown below on this change sheet.

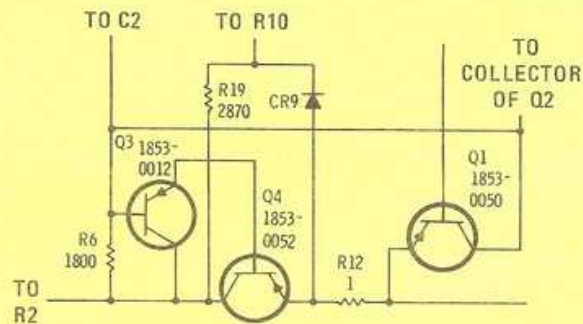

Partial Schematic 8-34. Power Supply (CHANGE 1)

HP 8746b 0.5-12.4 GHz S-parameter test-set

08746-90007

Model 8746B

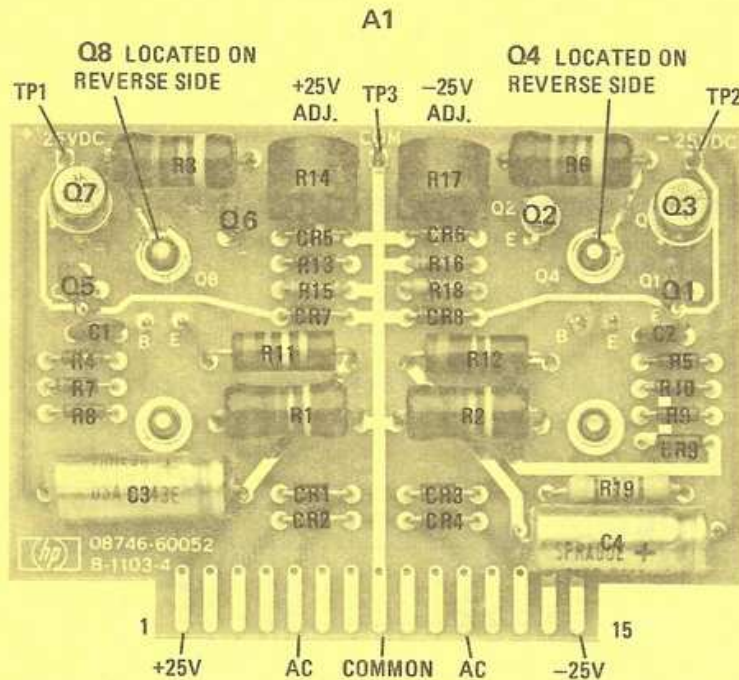

Figure 8-32. A1 Power Supply Assy Parts Location (Change 1)

CHANGE 2

Page 6-13, Figure 6-1:

Add the following note as an aid in explaining the 8746B color scheme.

NOTE

This change implements a different color scheme for the standard instrument. Colors prior to this change are now available as options. Refer to the listing below.

8746B STANDARD - Indicates color scheme for the 8746B beginning with this change.

8746B OPTION A85 - Indicates LIGHT GRAY front panel.

8746B OPTION X95 - Indicates color scheme for the 8746B prior to this change. Indicates LIGHT GRAY front panel with BLUE GRAY cabinet).

Page 6-13, Figure 6-1:

Change Item 3 to:

HP Part No. 08743-00019 COVER ASSY:TOP (OLIVE GRAY)(STANDARD)

HP Part No. 08743-00004 COVER ASSY:TOP (BLUE GRAY)(OPTION X95)

Change Item 4 to:

HP Part No. 08746-00021 PANEL:REAR (MINT GRAY)

HP Part No. 08746-00005 PANEL:REAR (LIGHT GRAY)(OPTION X95)

Change Item 5 to:

HP Part No. 08746-60023 FILLER PIECE:SIDE FRAME (MINT GRAY)

HP Part No. 08743-00007 FILLER PIECE:SIDE FRAME (LIGHT GRAY)(OPTION X95)

HP 8746b 0.5-12.4 GHz S-parameter test-set

Model 8746B

08746-90007

CHANGE 2 (cont'd)

Change Item 6 to:

HP Part No. 08746-00023 FILLER PIECE:SIDE FRAME (OLIVE GRAY) (STANDARD)

HP Part No. 08746-00008 FILLER PIECE:SIDE FRAME (BLUE GRAY)(OPTION X95)

Change Item 8 to:

HP Part No. 08746-00019 COVER:TOP REAR CORNER (OLIVE GRAY) (STANDARD)

HP Part No. 08746-00004 COVER:TOP REAR CORNER (BLUE GRAY)(OPTION X95)

Change Item 11 to:

HP Part No. 5060-8737 RETAINER:HANDLE ASSEMBLY (OLIVE GRAY)(STANDARD)

HP Part No. 5060-0766 RETAINER:HANDLE ASSEMBLY (BLUE GRAY)(OPTION X95)

Change Item 12 to:

HP Part No. 5000-8705 REAR SIDE COVER (OLIVE GRAY)(STANDARD)

HP Part No. 5000-0736 REAR SIDE COVER (BLUE GRAY)(OPTION X95)

Change Item 13 to:

HP Part No. 5000-8707 FRONT SIDE COVER (OLIVE GRAY)(STANDARD)

HP Part No. 5000-0737 FRONT SIDE COVER (BLUE GRAY)(OPTION X95)

Change Item 16 to:

HP Part No. 5060-0268 BOTTOM COVER ASSEMBLY (OLIVE GRAY)(STANDARD)

HP Part No. 5060-0228 BOTTOM COVER ASSEMBLY (BLUE GRAY)(OPTION X95)

Change Item 18 to:

HP Part No. 5060-8740 KIT:RACK MOUNT (OLIVE GRAY)(STANDARD)

HP Part No. 5060-0775 KIT:RACK MOUNT (BLUE GRAY)(OPTION A85, X95)

Page 6-14, Figure 6-2:

Change Item 2 to:

HP Part No. 08746-00022 PANEL FRONT:LOWER (MINT GRAY)(STANDARD)

HP Part No. 08746-00007 PANEL FRONT:LOWER (LIGHT GRAY)(OPTION A85, X95)

Change Item 4 to:

HP Part No. 08746-20056 PANEL FRONT(BACKING PLATE)(OLIVE GRAY)(STANDARD)

HP Part No. 08746-20008 PANEL FRONT(BACKING PLATE)(BLUE GRAY)(OPTION X95)

CHANGE 3

Page 3-12, paragraph 3-41:

The Bias and Bias Sense fuses have been moved to the rear panel. Replace the fuses with a 1/2 amp fuse (HP Part No. 2110-0046).

Page 6-3, Table 6-2:

Add A2C3-10, HP Part No. 0160-0174, C: FXD 0.47 UF -20+80% 25 VDCW, 56289, 5C11B7-CML.

Change A2CR2,4, 7, 10, 14, 17, 21, 25, & 32 to, HP Part No. 1902-0579, DIODE SILICON 5. 11 V ±5%, 04713, SZ 11213-56.

Add A2CR33-40, HP Part No. 1901-0025, DIODE: SILICON 100 MA/1 V, 07263, FD 2387.

Change A2Q1 to HP Part No. 1853-0020, TSTR: SI NPN (SELECTED FROM 2N3702), 28480, 1852-0020.

Page 6-4, Table 6-2:

Change A2Q2, 4, 6, 8, 10, 12, 14 & 16 to HP Part No. 1854-0071 TSTR: SI NPN (SELECTED FROM 2N3704), 28480, 1854-0071.

Change A2Q3, 5, 7, 9, 11, 13, & 15 to HP Part No. 1853-0020 TSTR: PNP (SELECTED FROM 2N3702), 28480, 1853-0020.

HP 8746b 0.5-12.4 GHz S-parameter test-set

08746-90007

Model 8746B

CHANGE 3 (cont'd)

Page 6-4, Table 6-2 (cont'd):

Change A2R1, 5, 10, 14, 18, 18, 22, 26, & 30 to HP Part No. 0698-4278.

Page 6-5, Table 6-2:

Add A3C6-9 HP Part No. 0160-0174 C:FXD 0.47 UF -20+80% 25 WVDC, 56289, 5C11B7-CML.

Change A3CR2, 4, 6, & 8 HP Part No. 1902-0579, DIODE: SILICON 5.11V ±5%, 04713, SZ 11213-56.

Add A3CR30-33 HP Part No. 1901-0025 DIODE: SILICON 100 MA/1V, 07263, FD 2387.

Change A3Q1, 3, 5, & 7 to HP Part No. 1853-0020 TSTR:SI PNP (SELECTED FROM 2N3702), 28480, 1853-0020.

Change A3Q2, 4, 6, & 8 to HP Part No. 1854-0071 TSTR:SI NPN (SELECTED FROM 2N3704), 28480, 1854-0071.

Page 6-6, Table 6-2:

Change A3R1, 5, 10, & 14 to HP Part No. 0698-4278 R:FXD 10K OHM 5% 1/8W, 28480, 0698-4278.

Page 6-11, Table 6-2:

Change F2-5 to HP Part No. 2110-0046 FUSE 0.5 AMP 250V, 28480, 2110-0046.

Page 8-21, Figure 8-16:

Change the latching circuits as shown on the attached schematic (Figure 8-16A).

Page 8-23, Figure 8-20:

Change the latching circuits as shown on the attached schematic (Figure 8-20).

CHANGE 4

Page 6-3, Table 6-2:

Add A2C11-18 HP Part No. 0150-0121 C:FXD CER .1 UF-20 +80% 50 VDCW.

Page 6-5, Table 6-2:

Add A3C10-13 HP Part No. 0150-0121 C:FXD CER .1 UF-20 +80% 50 VDCW.

Page 8-21, Figure 8-16:

Change the latching circuits as shown on the attached schematic:
Figure 8-16B (CHANGE 4)

Page 8-23, Figure 8-20:

Change the latching circuits as shown on the attached schematic:
Figure 8-20B (CHANGE 4)

CHANGE 5

Page 6-5, Table 6-2:

Add A2R70-77 HP Part No. 0683-1055 RESISTOR 1M 5% .25W FC TC= -800/+900.

Page 6-7, Table 6-2:

Add A3R83-86 HP Part No. 0683-1055 RESISTOR 1M 5% .25W FC TC= -800/+900.

Page 6-10, Table 6-2:

Delete A9C1 A, B.

Page 6-11, Table 6-2:

Add the following: HP Part No. 7120-4162 LABEL INFO QTY 1.
 HP Part No. 7120-4163 LABEL INFO QTY 1.

Page 8-21, Figure 8-16:

Change the latching circuits as shown on the attached schematic: Figure 8-16C (CHANGE 5).

Page 8-23, Figure 8-20:

Change the latching circuits as shown on the attached schematic: Figure 8-20C (CHANGE 5).

Page 8-29, Figure 8-34:

Delete A9C1A and A9C1B.

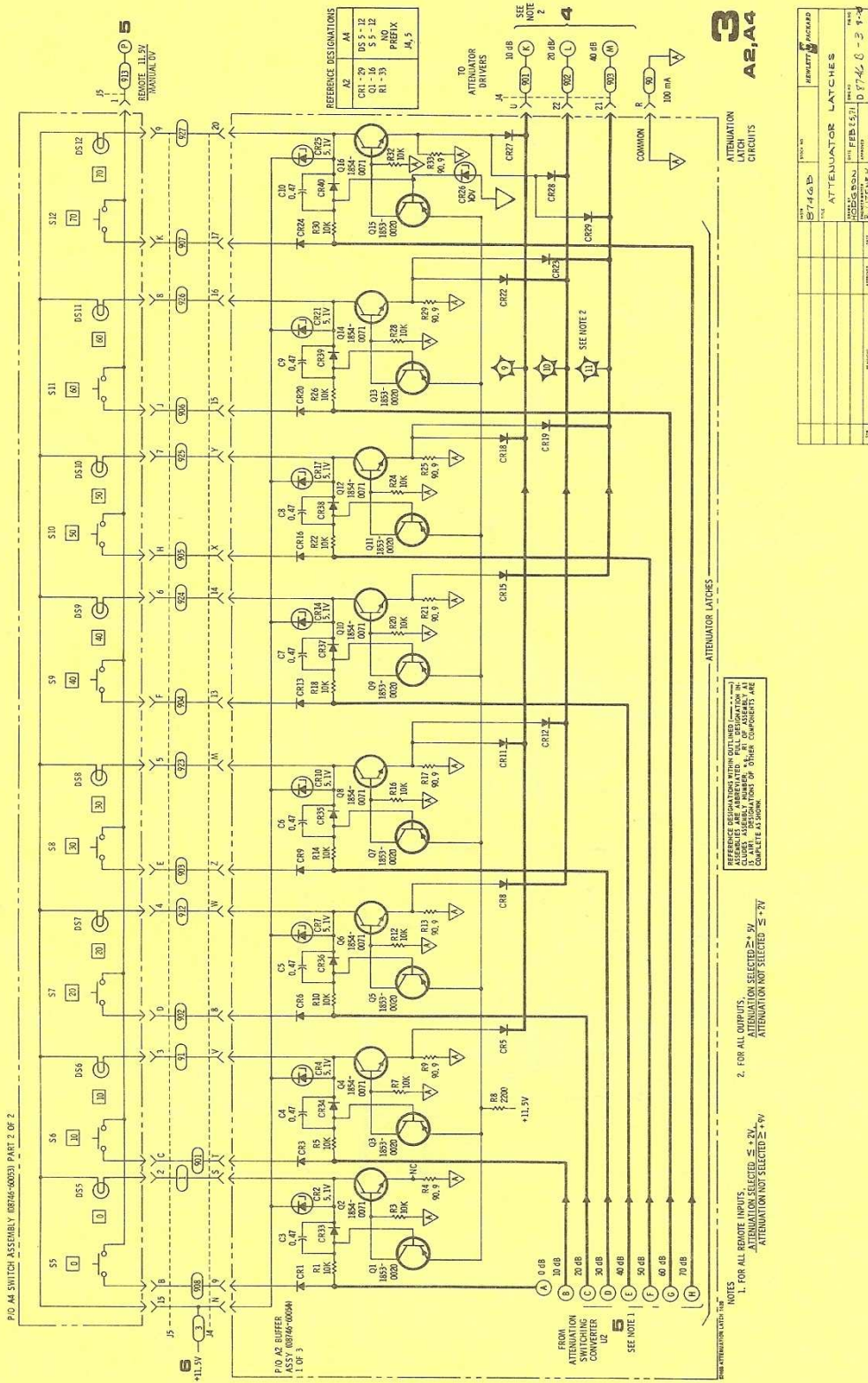

Figure 8-20A. Attenuation Latch Circuits (CHANGE 3)

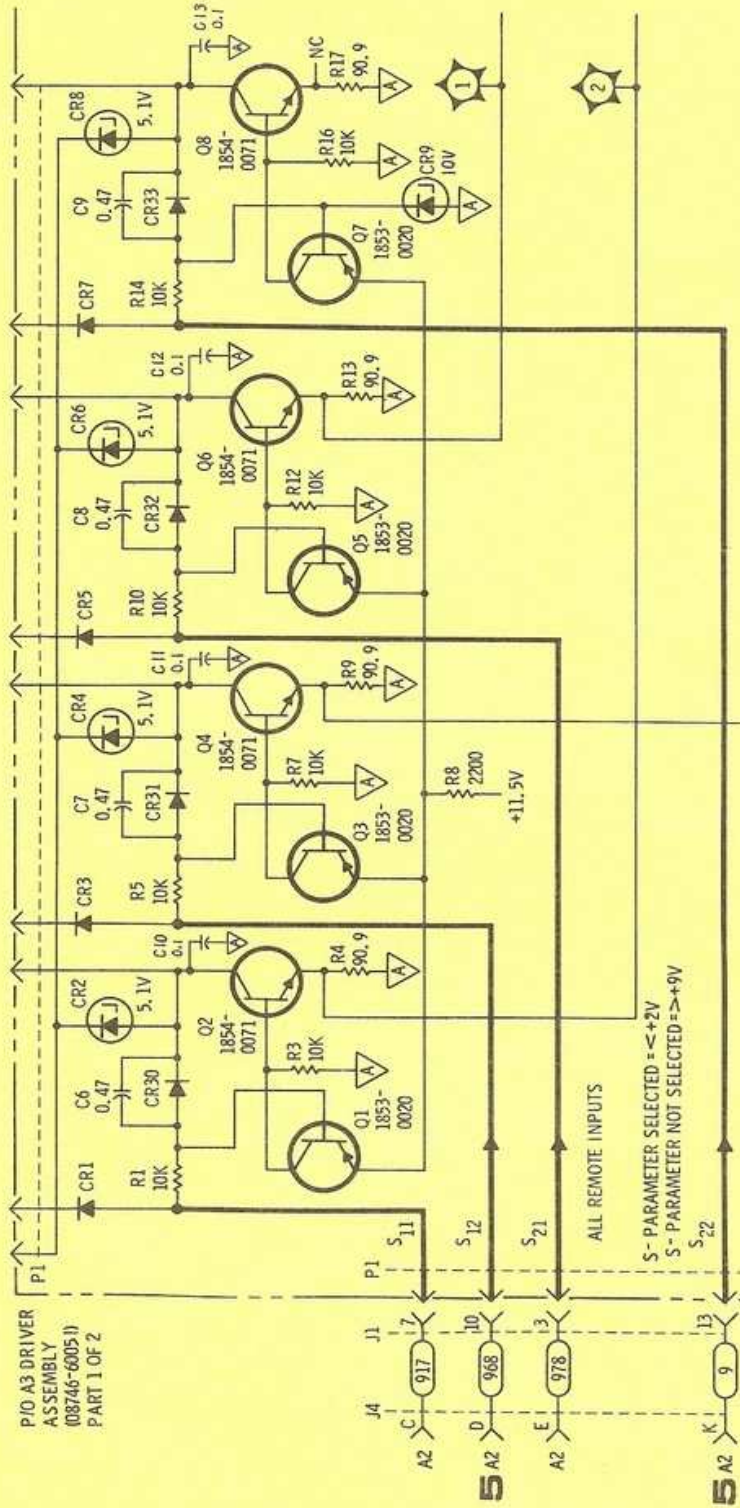

Figure 8-16B. Partial Schematic of A3 Latching Circuits (CHANGE 4)

HP 8746b 0.5-12.4 GHz S-parameter test-set

08746-90007

Model 8746B

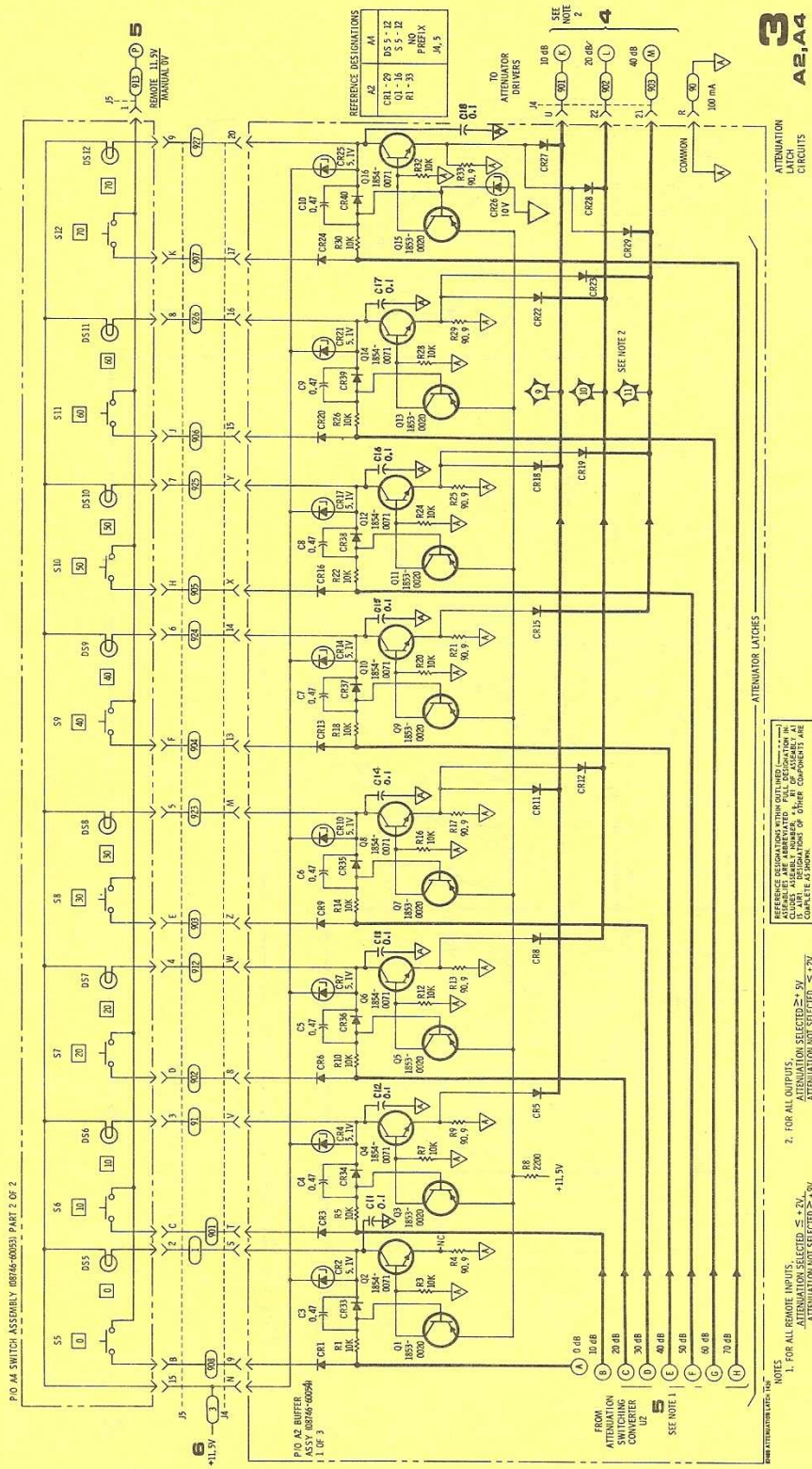

Figure 8-20B. Attenuation Latch Circuits (CHANGE 4)

HP 8746b 0.5-12.4 GHz S-parameter test-set

Model 8746B

08746-90007

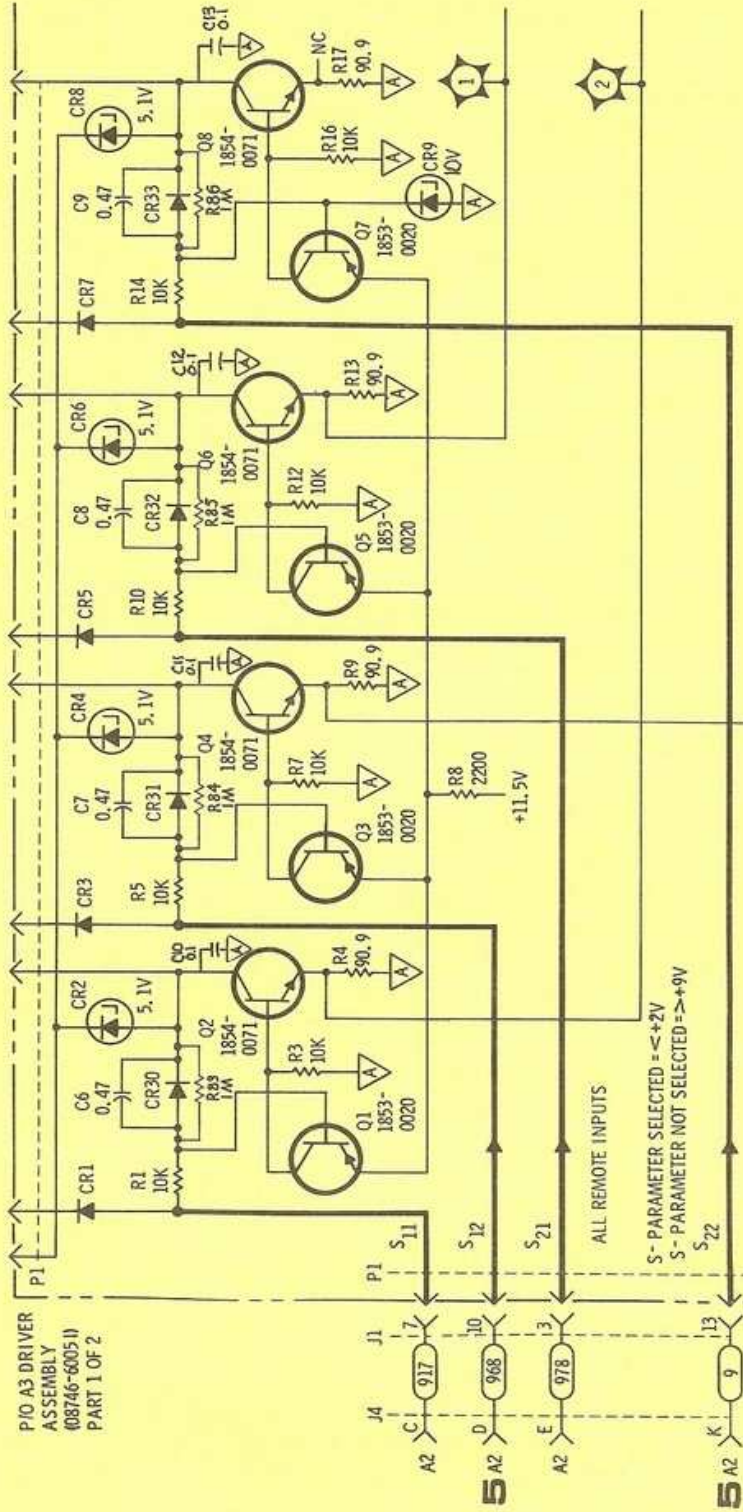

Figure 8-16C. Partial Schematic of A3 Latching Circuits (CHANGE 5)

HP 8746b 0.5-12.4 GHz S-parameter test-set

08746-90007

Model 8746B

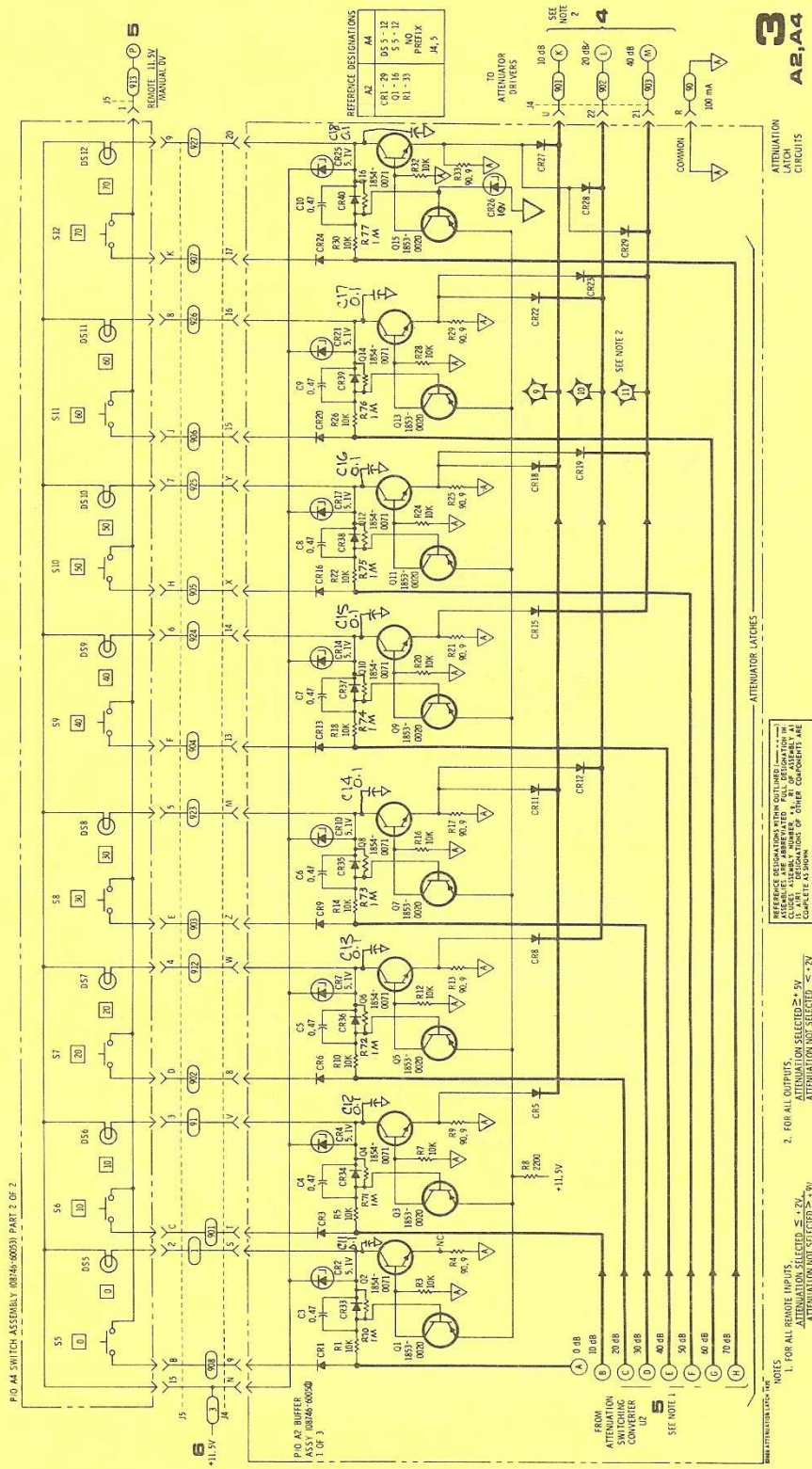

Figure 8-20C. Attenuation Latch Circuits (CHANGE 5)

CHANGE 6

Page 6-3, Table 6-2:

Change A2CR26 to HP Part No. 1902-3160 DIODE: BREAKDOWN 10.0V 2% 400MW.

Change A2CR30 to HP Part No. 1902-3183 DIODE: BREAKDOWN SILICON 12.1V 2%.

Page 6-5, Table 6-2:

Change A3CR9 to HP Part No. 1902-3160 DIODE: BREAKDOWN 10.0V 2% 400MW.

Page 6-6, Table 6-2:

Change A3R40-43 to HP Part No. 0683-0275 R:FXD COMP 2.7 OHM 5% 1/4W.

CHANGE 7

Page 6-5, Table 6-2:

Add A3C14 HP Part No. 0160-0174 C:FXD .47 μ F.

Delete A3CR9.

Page 6-3, Table 6-2:

Add A2C19 HP Part No. 0160-0174 C:FXD .47 μ F.

Delete A2CR26.

Page 8-21, Figure 16:

Change A3CR9 to a .47 μ F capacitor (A3C14).

Page 8-23, Figure 8-20:

Change A2CR26 to a .47 μ F capacitor (A2C19).

CHANGE 8

Page 8-29, Figure 8-34:

Change A9 Power Module Assembly as shown on the attached schematic: Figure 8-34A (CHANGE 8).

CHANGE 9

Page 6-10, Table 6-2:

Change A9 to HP Part No. 0960-0504 POWER LINE MODULE ASSY.

HP 8746b 0.5-12.4 GHz S-parameter test-set

08746-90007

Model 8746B

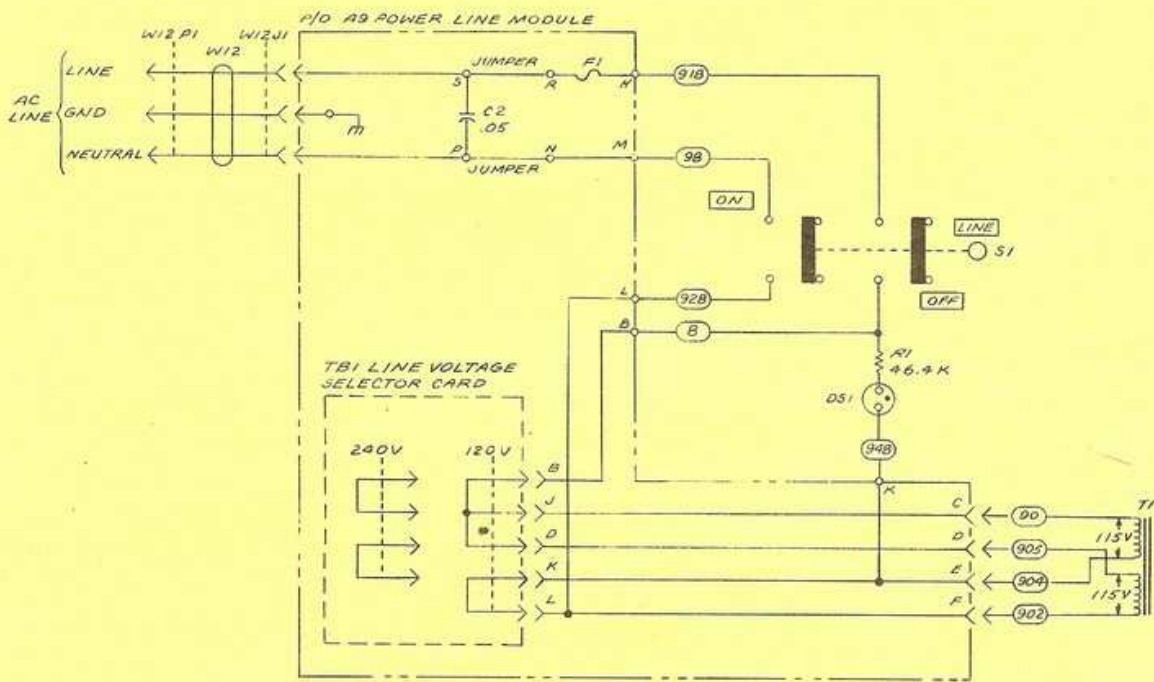

Figure 8-34A. Power Supply Partial Schematic